

12/16K ROM HCMOS MCUs

- Register oriented 8/16 bit CORE with RUN, WFI and HALT modes
- Minimum instruction cycle time : 500ns (12MHz internal)
- Internal Memory :

	ROM	RAM
ST9020	12K	
ST9027	16K	256
ST9028	16K	256

224 general purpose registers available as RAM, accumulators or index registers (register file)
- 40-pin Plastic Dual in line Package for ST9020, ST9027
- 44-lead Plastic Leaded Chip Carrier package for ST9028C
- 56-pin Plastic Dual in line Package for ST9028B
- DMA controller, Interrupt handler and Serial Peripheral Interface as standard features
- Up to 40 fully programmable I/O pins
- Up to 8 external plus 1 non-maskable interrupts
- 16 bit Timer with an 8-bit Prescaler, able to be used as a Watchdog Timer
- 16 bit Multifunction Timer, with an 8-bit Prescaler and 12 operating modes
- Serial Communications Interface with asynchronous and synchronous capability
- Rich Instruction Set and 14 Addressing modes
- Division-by-Zero trap generation
- Versatile development tools, including assembler, linker, C-compiler, archiver, graphic oriented debugger and hardware emulators
- Real Time Operating System
- Windowed and One Time Programmable EPROM parts available for prototyping and pre-production development phases

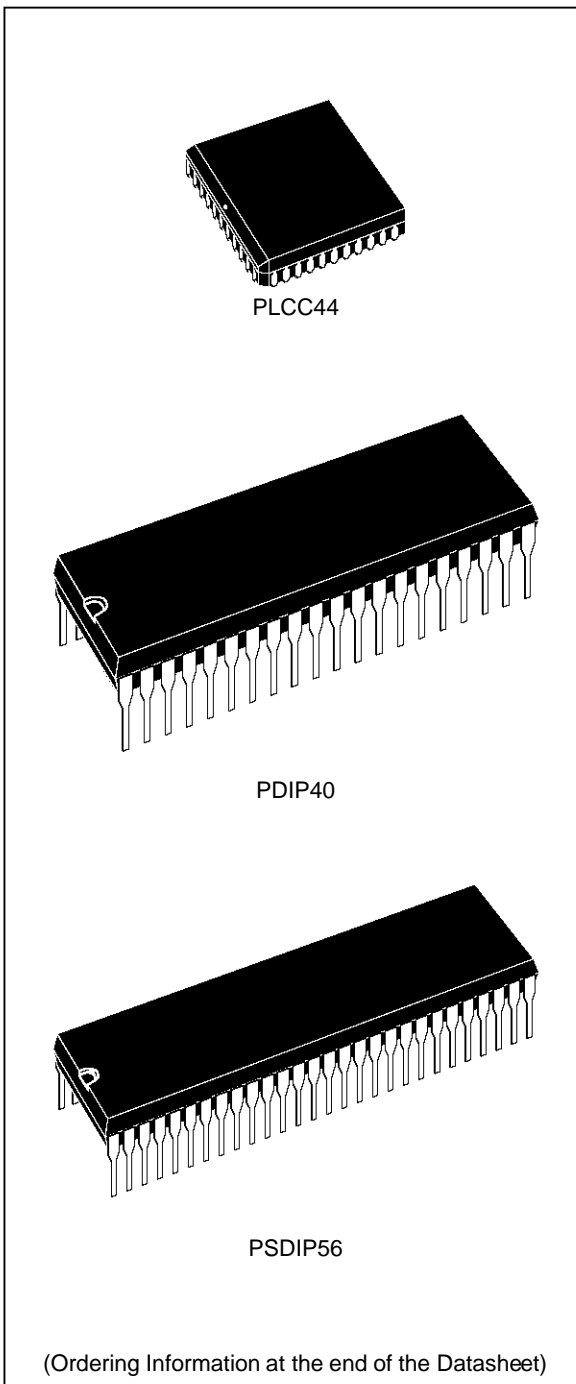

Table of Contents

	Page Number
ST9020, ST9027& ST9028	1
1.1 GENERAL DESCRIPTION	10
1.2 PIN DESCRIPTION	11
1.2.1 I/O Port Alternate Functions	11
2 CORE ARCHITECTURE	15
2.1 CORE ARCHITECTURE	15
2.2 ADDRESS SPACES	15
2.2.1 Register File	15
2.2.2 Addressing Registers	17
2.2.3 Input/Output Ports	17
2.3 SYSTEM REGISTERS	19
2.3.1 Central Interrupt Control Register	19
2.3.2 Flag Register	20
2.3.3 Register Pointing Techniques	21
2.3.4 Page Configuration	23
2.3.5 Mode Registers	23
2.3.6 Stack Pointers	24
3 MEMORY	27
3.1 INTRODUCTION	27
3.2 PROGRAM SPACE DEFINITION	28
3.3 DATA SPACE DEFINITION	28
4 INTERRUPTS	29
4.1 INTRODUCTION	29
4.2 INTERRUPT VECTORIZATION	29
4.3 INTERRUPT PRIORITY LEVEL ARCHITECTURE	31
4.4 PRIORITY LEVEL ARBITRATION	31
4.4.1 Concurrent Mode	32
4.4.2 Nested Mode	35
4.5 EXTERNAL INTERRUPTS	38
4.6 TOP LEVEL INTERRUPT	40
4.7 ON-CHIP PERIPHERAL INTERRUPTS	40
4.8 WAIT FOR INTERRUPT INSTRUCTION	42
4.9 INTERRUPT RESPONSE TIME	42
4.10 INTERRUPT REGISTERS	44

Table of Contents

	Page Number
5 ON-CHIP DMA	47
5.1 INTRODUCTION	47
5.2 DMA PRIORITY LEVEL ARCHITECTURE	47
5.3 DMA TRANSACTIONS	49
5.4 DMA CYCLE TIME	49
5.5 THE SWAP-MODE	52
5.6 DMA REGISTERS	52
6 CLOCK	53
6.1 INTRODUCTION	53
6.2 CLOCK MANAGEMENT	53
6.3 CLOCK CONTROL REGISTER	54
6.4 OSCILLATOR CHARACTERISTICS	55
7 RESET	57
7.1 INTRODUCTION	57
7.2 RESET GENERATION	57
7.3 RESET PIN TIMING	57
7.4 PROCESSOR SYNCHRONIZATION UNDER RESET	57
8 EXTERNAL MEMORY INTERFACE	61
8.1 INTRODUCTION	61
8.2 CONTROL SIGNALS	61
8.3 MEMORY ACCESS CYCLE	63
8.4 STRETCHED ACCESS CYCLE	63
8.5 SHARED BUS	66
8.6 PORTS P0, P1 INITIALIZATION AFTER RESET	67
8.7 PIPELINE	68
8.8 "SPURIOUS" MEMORY READ ACCESSES	69
8.9 REGISTERS	70
9 I/O PORTS	71
9.1 INTRODUCTION	71
9.2 CONTROL REGISTERS	71
9.3 PORT BIT STRUCTURE AND PROGRAMMING	72
9.4 ALTERNATE FUNCTION ARCHITECTURE	75
9.5 I/O STATUS AFTER WFI, HALT AND RESET	76

Table of Contents

	Page Number
10 HANDSHAKE/DMA CONTROLLER	77
10.1 INTRODUCTION	77
10.2 PROGRAMMABLE HANDSHAKE MODES	78
10.2.1 Input Handshake	78
10.2.2 Output Handshake	80
10.2.3 Bidirectional Handshake	82
10.2.4 Application example: Mapping an ST9 onto the memory bus of another ST9	83
10.3 PROGRAMMABLE DMA MODES	84
10.3.1 DMA Transfers Driven By Timer CAPT0 Channel With Handshake	84
10.3.2 DMA Input transfers with two line input handshake	84
10.3.3 DMA output transfers with two lines output handshake	85
10.3.4 DMA input transfers with one line input handshake	85
10.3.5 DMA output transfers with one line output handshake	86
10.3.6 DMA input/output transfers with bidirectional handshake	86
10.3.7 DMA Transfers Driven By Timer	87
10.4 HANDSHAKE/DMA CONTROL REGISTERS	88
11 SERIAL PERIPHERAL INTERFACE	91
11.1 INTRODUCTION	91
11.2 FUNCTIONAL DESCRIPTION	92
11.2.1 Input Signal Description	92
11.2.2 Output Signal Description	92
11.3 INTERRUPT STRUCTURE	93
11.4 SPI REGISTERS	94
11.5 WORKING with DIFFERENT PROTOCOLS	95
11.5.1 I ² C-bus Interface	95
11.5.2 S-Bus Interface	98
11.5.3 IM-Bus Interface	99
12 TIMER/WATCHDOG	101
12.1 INTRODUCTION	101
12.2 FUNCTIONAL DESCRIPTION	102
12.2.1 Timer/Counter Input Modes	102
12.2.2 Timer/Watchdog Output Modes	102
12.2.3 Timer/Counter Control	102
12.2.4 Timer/Watchdog Mode	103
12.3 TIMER/WATCHDOG INTERRUPT	104
12.4 TIMER/WATCHDOG REGISTERS	105

Table of Contents

	Page Number
13 MULTIFUNCTION TIMER	107
13.1 INTRODUCTION	107
13.2 FUNCTIONAL DESCRIPTION	109
13.2.1 One Shot Mode	109
13.2.2 Continuous Mode	109
13.2.3 Trigger And Retrigger Modes	109
13.2.4 Gate Mode	109
13.2.5 Capture Mode	109
13.2.6 Up/Down Mode	109
13.2.7 Free Running Mode	109
13.2.8 Monitor Mode	110
13.2.9 Autoclear Mode	110
13.2.10 Bivalue Mode	110
13.2.11 Parallel Mode	110
13.2.12 Autodiscriminator Mode	110
13.3 INPUT PIN ASSIGNMENT	111
13.3.1 TxINA = I/O - TxINB = I/O	111
13.3.2 TxINA = I/O - TxINB = Trigger	111
13.3.3 TxINA = Gate - TxINB = I/O	111
13.3.4 TxINA = Gate - TxINB = Trigger	112
13.3.5 TxINA = I/O - TxINB = Ext. Clock	112
13.3.6 TxINA = Trigger - TxINB = I/O	112
13.3.7 TxINA = Gate - TxINB = Ext. Clock	112
13.3.8 TxINA = Trigger - TxINB = Trigger	112
13.3.9 TxINA = Clock Up - TxINB = Clock Down	112
13.3.10 TxINA = Up/Down - TxINB = Ext Clock	112
13.3.11 TxINA = Trigger Up - TxINB = Trigger Down	113
13.3.12 TxINA = Up/Down - TxINB = I/O	113
13.3.13 Autodiscrimination Mode	113
13.3.14 TxINA = Trigger - TxINB = Ext. Clock	113
13.3.15 TxINA = Ext. Clock - TxINB = Trigger	113
13.3.16 TxINA = Trigger - TxINB = Gate	113
13.4 OUTPUT PIN ASSIGNMENT	114
13.5 INTERRUPT AND DMA	116
13.5.1 Timer Interrupt	116
13.5.2 Timer DMA	116
13.5.3 DMA Pointers	116
13.5.4 Priority During The DMA Transactions	117
13.5.5 The DMA Swap Mode	117
13.5.6 The DMA End Of Block Interrupt Routine	118
13.5.7 DMA Software Protection	118

Table of Contents

	Page Number
13.6	TIMER DMA EXTERNAL MODES ON I/O PORTS 118
13.6.1	CM0 Channel External Mode 118
13.6.2	CP0 Channel In External Mode 118
13.6.3	DMA Channel Synchronization 119
13.7	REGISTER DESCRIPTION 120
13.7.1	Register 0 (REG0R) Registers 121
13.7.2	Register 1 (REG1R) Registers 121
13.7.3	Compare 0 (CMP0R) Registers 121
13.7.4	Compare 1 (CMP1R) Registers 121
13.7.5	Timer Control Register (TCR) 122
13.7.6	Timer Mode Register (TMR) 122
13.7.7	External Input Control Register(ICR) 123
13.7.8	Prescaler Register (PRSR) 124
13.7.9	Output A Control Register (OACR) 124
13.7.10	Output B Control Register (OBCR) 125
13.7.11	Flag Register (FLAGR) 125
13.7.12	Interrupt/DMA Mask Register (IDMR) 126
13.7.13	DMA Counter Pointer Register (DCPR) 126
13.7.14	DMA Address Pointer Register (DAPR) 127
13.7.15	Interrupt Vector Register (IVR) 127
13.7.16	Interrupt/DMA Control Register (IDCR) 128
13.7.17	I/O Connection Register (IOCR) 128
14	SERIAL COMMUNICATIONS INTERFACE 129
14.1	INTRODUCTION 129
14.2	FUNCTIONAL DESCRIPTION 130
14.2.1	Serial Frame Format 131
14.2.2	Clocks And Serial Transmission Rates 133
14.2.3	Input Signals 135
14.2.4	Output Signals 135
14.3	INTERRUPTS AND DMA 135
14.3.1	Interrupts 135
14.3.2	DMA 137
14.4	CONTROL REGISTERS 137
	REGISTER MAP 145
15	ELECTRICAL CHARACTERISTICS 149

Table of Contents

	Page Number
ST90E27/T27 & ST90E28/T28	167
16.1 GENERAL DESCRIPTION	170
16.2 PIN DESCRIPTION	171
16.3 I/O PORT ALTERNATE FUNCTIONS	171
16.4 MEMORY	174
16.5 EPROM PROGRAMMING	174
16.5.1 Eprom Erasing	174
 ST90R28	 189
17.1 GENERAL DESCRIPTION	190
17.2 PIN DESCRIPTION	191
17.3 I/O PORT ALTERNATE FUNCTIONS	191
17.4 MEMORY	191

ST9020, ST9027, ST9028

Figure 1-1. 40 Pin DIP Package

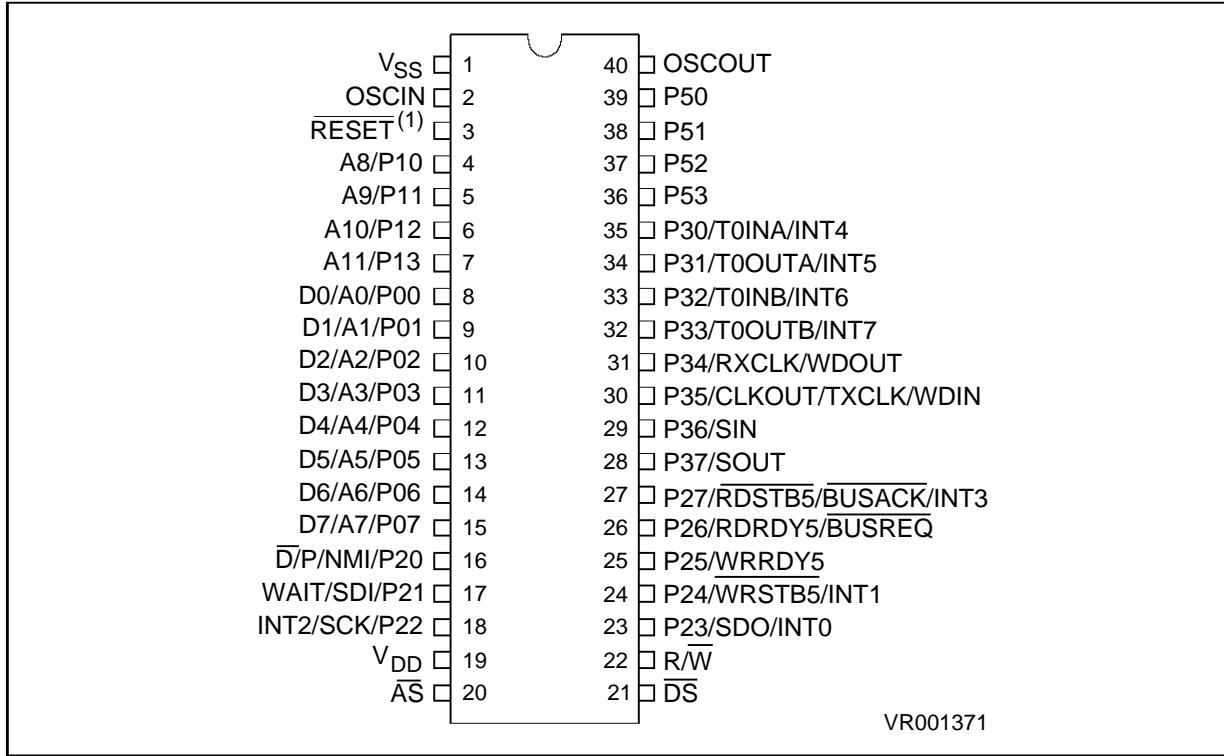

Note 1. This pin is also the VPP input for the EPROM based devices

Figure 1-2. 44 Pin PLCC Package

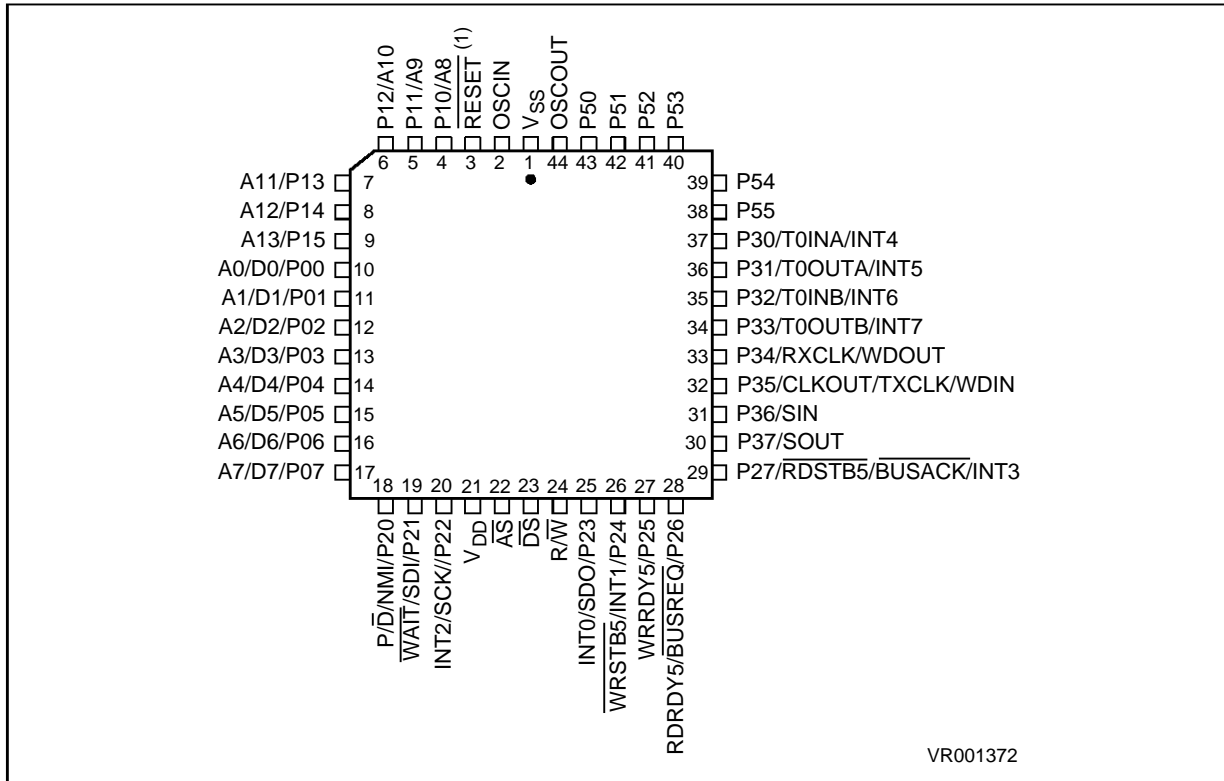

Note 1. This pin is also the VPP input for the EPROM based devices

Figure 1-3. 56 Pin DIP Package

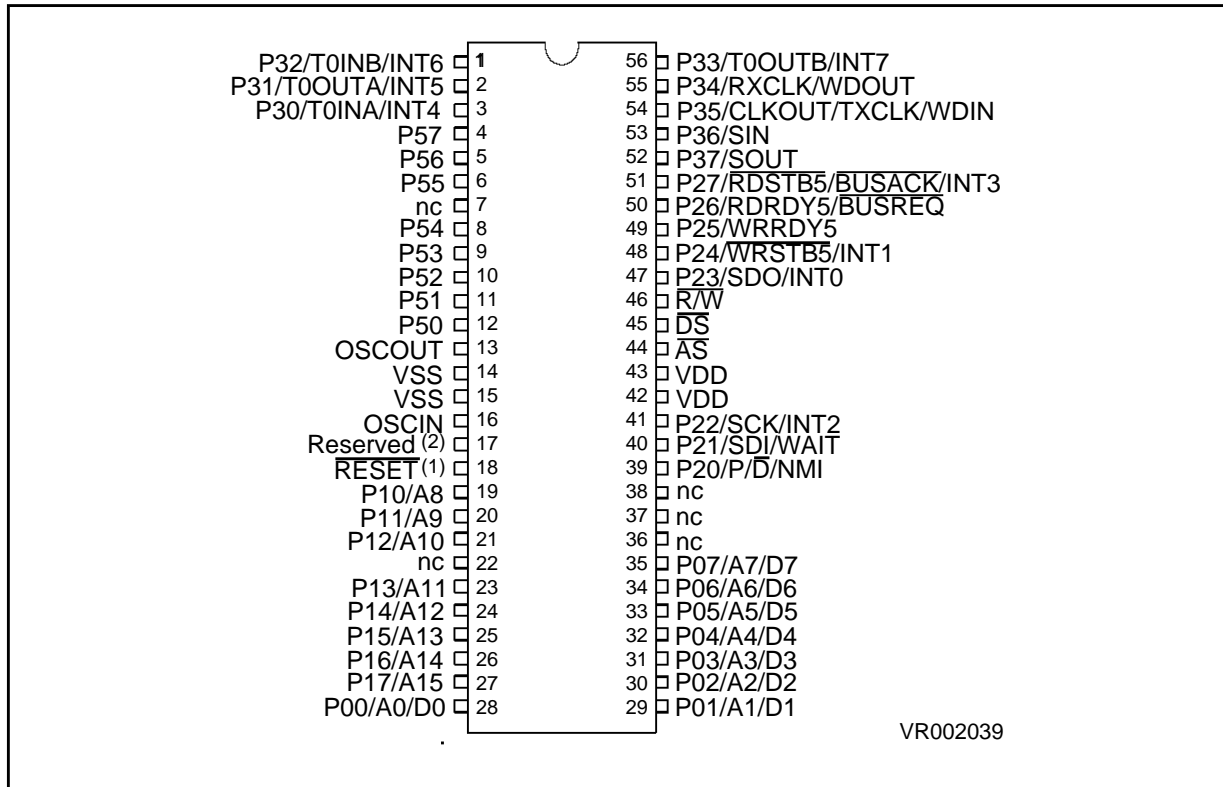

Note 1. This pin is also the VPP input for the EPROM based devices

1.1 GENERAL DESCRIPTION

The ST9020, ST9027 and ST9028 (following mentioned as ST902X) are ROM members of the ST9 family of microcontrollers, completely developed and produced by SGS-THOMSON Microelectronics using a proprietary n-well HCMOS process.

The ROM parts are fully compatible with their EPROM versions, which may be used for the prototyping and pre-production phases of development, and can be configured as : stand-alone microcontrollers with 16K bytes of on-chip ROM, (12K for ST9020), microcontrollers able to manage up to 16K bytes of external data memory, or as parallel processing elements in a system with other processors and peripheral controllers.

A key point of the ST902X architecture is its modular approach which allows software commonality with all other members of the ST9 family.

The nucleus of the modular design of the ST902X is the advanced Core which includes the Central Processing Unit (CPU), the Register File, a 16 bit Timer/Watchdog with 8 bit Prescaler, a Serial Peripheral Interface supporting S-bus, I²C-bus and IM-bus Interface, plus two 8 bit I/O ports. The Core has independent memory and register buses allowing a high degree of pipelining to add to the efficiency of the code execution speed of the extensive instruction set.

The powerful I/O capabilities demanded by micro-controller applications are fulfilled by the ST902X with up to 40 I/O lines dedicated to digital Input/Output. These lines are grouped into up to three 8 bit I/O Ports plus two 6-bit I/O ports and can be configured on a bit basis under software control to provide timing, status signals, an address/data bus for interfacing external memory, timer inputs and outputs, external interrupts and serial or parallel I/O with or without handshake.

Three basic memory spaces are available to support this wide range of configurations: Program Memory (internal), Data Memory (internal/external) and the Register File, which includes the control and status registers of the on-chip peripherals.

The 16 bit MultiFunction Timer, with an 8 bit Prescaler and 12 operating modes allows simple use for complex waveform generation and measurement, PWM functions and many other system timing functions by the usage of the two associated DMA channels for each timer.

Completing the device is a full duplex Serial Communications Interface with an integral 110 to 375000 baud rate generator, asynchronous and byte synchronous capability (fully programmable format) and associated address/wake-up option, plus two DMA channels.

Figure 1-4. ST902X Block Diagram

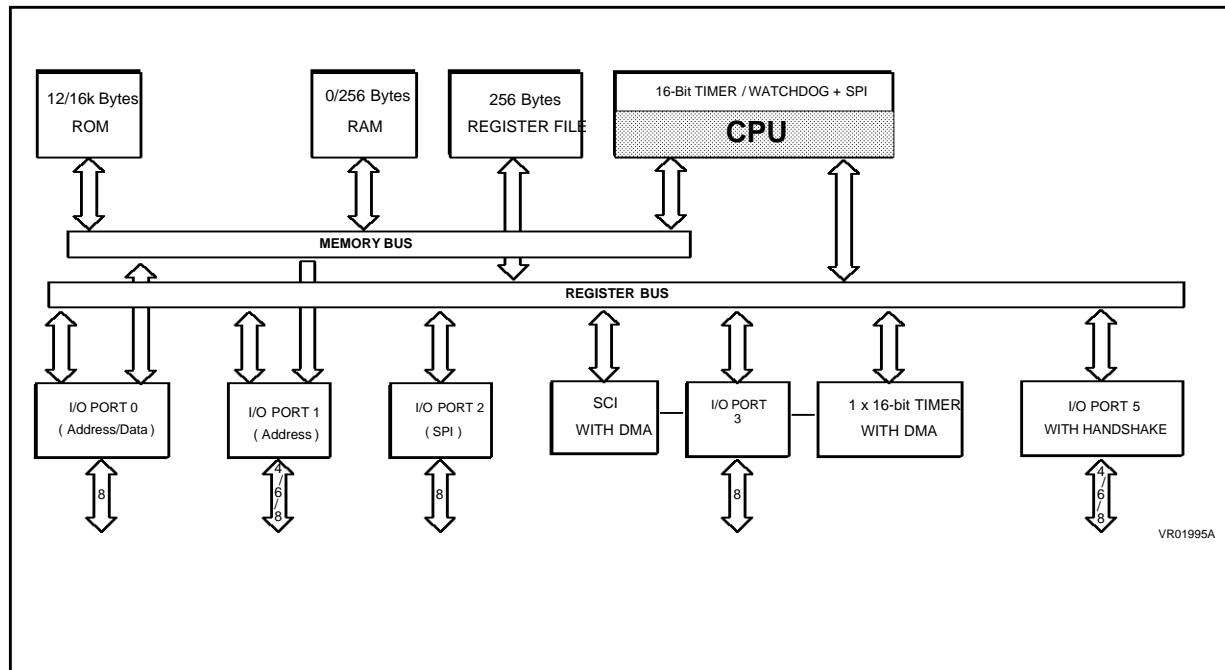

1.2 PIN DESCRIPTION

\overline{AS} . *Address Strobe (output, active low, 3-state).* Address Strobe is pulsed low once at the beginning of each memory cycle. The rising edge of \overline{AS} indicates that address, Read/Write (R/\overline{W}), and Data Memory signals are valid for program or data memory transfers. Under program control, \overline{AS} can be placed in a high-impedance state along with Port 0 and Port 1, Data Strobe (\overline{DS}) and R/\overline{W} .

\overline{DS} . *Data Strobe (output, active low, 3-state).* Data Strobe provides the timing for data movement to or from Port 0 for each memory transfer. During a write cycle, data out is valid at the leading edge of \overline{DS} . During a read cycle, Data In must be valid prior to the trailing edge of \overline{DS} . When the ST902x accesses on-chip memory, \overline{DS} is held high during the whole memory cycle. It can be placed in a high impedance state along with Port 0, Port 1, \overline{AS} and R/\overline{W} .

R/\overline{W} . *Read/Write (output, 3-state).* Read/Write determines the direction of data transfer for external memory transactions. R/\overline{W} is low when writing to external program or data memory, and high for all other transactions. It can be placed in a high impedance state along with Port 0, Port 1, \overline{AS} and \overline{DS} .

\overline{RESET} . *Reset (input, active low).* The ST9 is initialised by the Reset signal. With the deactivation of $\overline{RE-$

\overline{SET} , program execution begins from the Program memory location pointed to by the vector contained in program memory locations 00h and 01h.

OSCIN, OSCOUT. *Oscillator (input and output).* These pins connect a parallel-resonant crystal (24MHz maximum), or an external source to the on-chip clock oscillator and buffer. OSCIN is the input of the oscillator inverter and internal clock generator; OSCOUT is the output of the oscillator inverter.

V_{DD} . Main Power Supply Voltage ($5V \pm 10\%$)

V_{SS} . Digital Circuit Ground.

P0.0-P0.7, P1.0-P1.7, P2.0-P2.7 P3.0-P3.7, P5.0-P5.7 *I/O Port Lines (Input/Output, TTL or CMOS compatible).* 32/36/40 lines grouped into I/O ports of 8 and 4/6/8 bits, bit programmable under program control as general purpose I/O or as alternate functions.

1.2.1 I/O Port Alternate Functions

Each pin of the I/O ports of the ST902x may assume software programmable Alternative Functions as shown in the Pin Configuration Drawings. Table 1-1 shows the Functions allocated to each I/O Port pins and a summary of packages for which they are available.

ST9020, ST9027, ST9028

PIN DESCRIPTION (Continued)

Table 1-1. ST902x I/O Port Alternate Function Summary

I/O PORT	Name	Function	Alternate Function	Pin Assignment		
				SDIP56	PDIP40	PLCC44
P0.0	A0/D0	I/O	Address/Data bit 0 mux	28	8	10
P0.1	A1/D1	I/O	Address/Data bit 1 mux	29	9	11
P0.2	A2/D2	I/O	Address/Data bit 2 mux	30	10	12
P0.3	A3/D3	I/O	Address/Data bit 3 mux	31	11	13
P0.4	A4/D4	I/O	Address/Data bit 4 mux	32	12	14
P0.5	A5/D5	I/O	Address/Data bit 5 mux	33	13	15
P0.6	A6/D6	I/O	Address/Data bit 6 mux	34	14	16
P0.7	A7/D7	I/O	Address/Data bit 7 mux	35	15	17
P1.0	A8	O	Address bit 8	19	4	4
P1.1	A9	O	Address bit 9	20	5	5
P1.2	A10	O	Address bit 10	21	6	6
P1.3	A11	O	Address bit 11	23	7	7
P1.4	A12	O	Address bit 12	24	-	8
P1.5	A13	O	Address bit 13	25	-	9
P1.6	A14	O	Address bit 14	26	-	-
P1.7	A15	O	Address bit 15	27	-	-
P2.0	NMI	I	Non-Maskable Interrupt	39	16	18
P2.0	$\overline{P/D}$	O	Program/Data Space Select	39	16	18
P2.1	SDI	I	SPI Serial Data In	40	17	19
P2.1	\overline{WAIT}	I	External Wait Input	40	17	19
P2.2	INT2	I	External Interrupt 2	41	18	20
P2.2	SCK	O	SPI Serial Clock	41	18	20
P2.3	INT0	I	External Interrupt 0	47	23	25
P2.3	SDO	O	SPI Serial Data Out	47	23	25
P2.4	INT1	I	External Interrupt 1	48	24	26
P2.4	$\overline{WRSTB5}$	I	Handshake Write Strobe P5	48	24	26
P2.5	WRRDY5	O	Handshake Write Ready P5	49	25	27
P2.6	RDRDY5	O	Handshake Read Ready P5	50	26	28

PIN DESCRIPTION (Continued)

Table 1-1. ST902x I/O Port Alternate Function Summary

I/O PORT	Name	Function	Alternate Function	Pin Assignment		
				SDIP56	PDIP40	PLCC44
P2.6	$\overline{\text{BUSREQ}}$	I	External Bus Request	50	26	28
P2.7	INT3	I	External Interrupt 1	51	27	29
P2.7	$\overline{\text{RDSTB5}}$	I	Handshake Read Strobe P5	51	27	29
P2.7	$\overline{\text{BUSACK}}$	O	External Bus Acknowledge	51	27	29
P3.0	INT4	I	External Interrupt 4	3	35	37
P3.0	T0INA	I	MF Timer 0 Input A	3	35	37
P3.1	INT5	I	External Interrupt 5	2	34	36
P3.1	T0OUTA	O	MF Timer 0 Output A	2	34	36
P3.2	INT6	I	External Interrupt 6	1	33	35
P3.2	T0INB	I	MF Timer 0 Input B	1	33	35
P3.3	INT7	I	External Interrupt 7	56	32	34
P3.3	T0OUTB	O	MF Timer 0 Output B	56	32	34
P3.4	RXCLK	I	SCI Receive Clock Input	55	31	33
P3.4	WDOUT	O	T/WD Output	55	31	33
P3.5	CLKOUT	O	SCI Byte Sync Clock Output	54	30	32
P3.5	TXCLK	I	SCI Transmit Clock Input	54	30	32
P3.5	WDIN	I	T/WD Input	54	30	32
P3.6	SIN	I	SCI Serial Input	53	29	31
P3.7	SOUT	O	SCI Serial Output	53	28	30
P5.0		O	I/O Handshake Port 5	12	39	43
P5.1		O	I/O Handshake Port 5	11	38	42
P5.2		O	I/O Handshake Port 5	10	37	41
P5.3		O	I/O Handshake Port 5	9	36	40
P5.4		O	I/O Handshake Port 5	8	-	39
P5.5		O	I/O Handshake Port 5	6	-	38
P5.6		O	I/O Handshake Port 6	5	-	-
P5.7		O	I/O Handshake Port 7	4	-	-

Notes :

2 CORE ARCHITECTURE

2.1 CORE ARCHITECTURE

The Core or Central Processing Unit (CPU) of the ST9 includes the 8 bit Arithmetic Logic Unit and the 16 bit Program Counter, System and User Stack Pointers. The microcoded Instruction Set is highly optimised for both byte (8 bit) and word (16 bit) data, BCD and Boolean data types, with 14 addressing modes.

Three independent buses are controlled by the Core, a 16 bit Memory bus, an 8 bit Register addressing bus and a 6 bit Interrupt/DMA bus connected to the interrupt and DMA controllers in the on-chip peripherals and the Core. This multiple bus architecture allows a high degree of pipelining and parallel operation, giving the ST9 its efficiency in both numerical calculations and communication with the on-chip peripherals.

2.2 ADDRESS SPACES

The ST9 has three separate address spaces:

- Register File: 240 8-bit registers plus up to 64 pages of 16 bytes each, located in the on-chip peripherals.
- Data memory with up to 64K (65536) bytes
- Program memory with up to 64K (65536) bytes

The Data and Program memory spaces will be addressed in further detail in the next section.

2.2.1 Register File

The Register File consists of:

- 224 general purpose registers R0 to R223
- 16 system registers in the System Group (R224 to R239).
- I/O pages depending on the configuration of the ST9, each containing up to 16 registers, with paging facilities based on the top group (R240 to R255).

Figure 2-1. Address Spaces

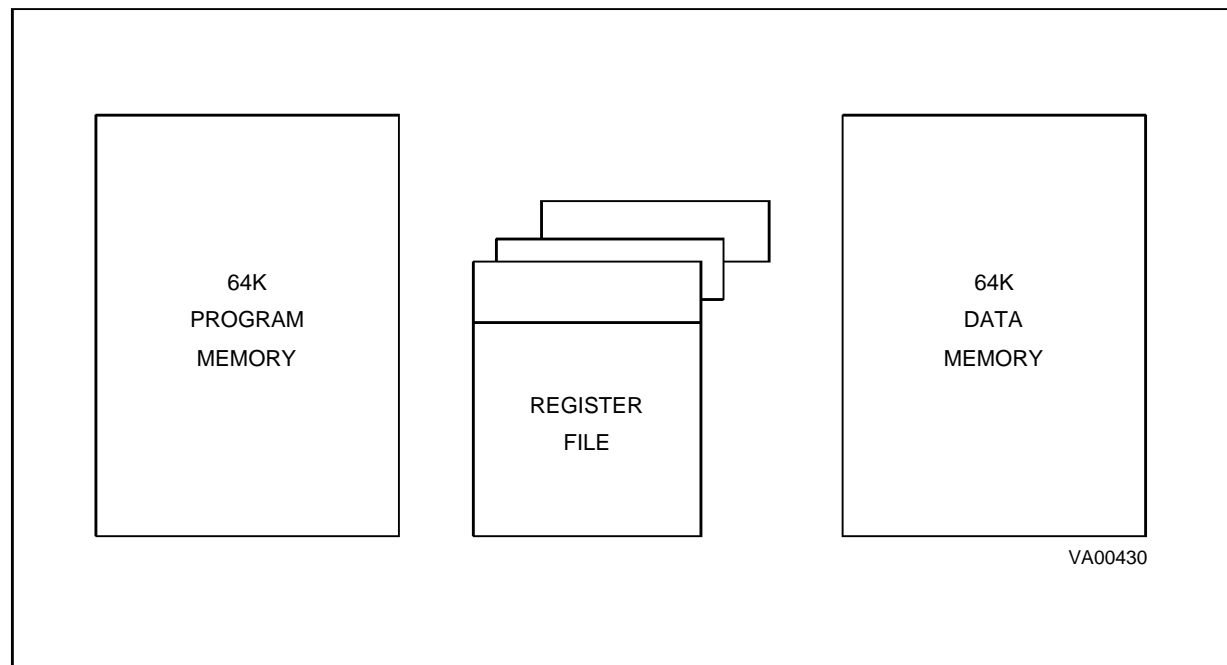

ST9 - Architecture (ST902x)

ADDRESS SPACES (Continued)

Figure 2-2. Register Grouping

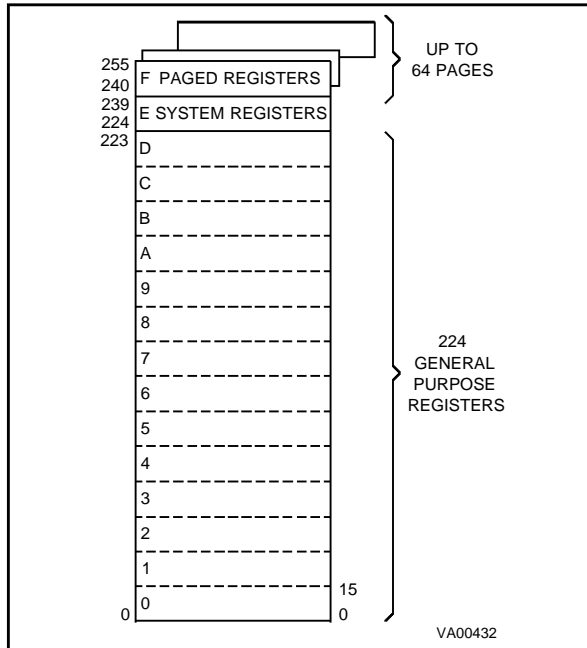

Figure 2-3. Page Pointer Configuration

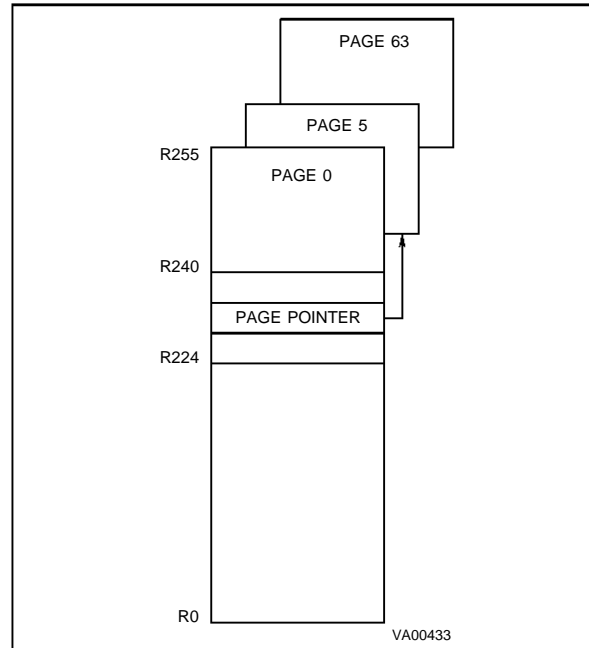
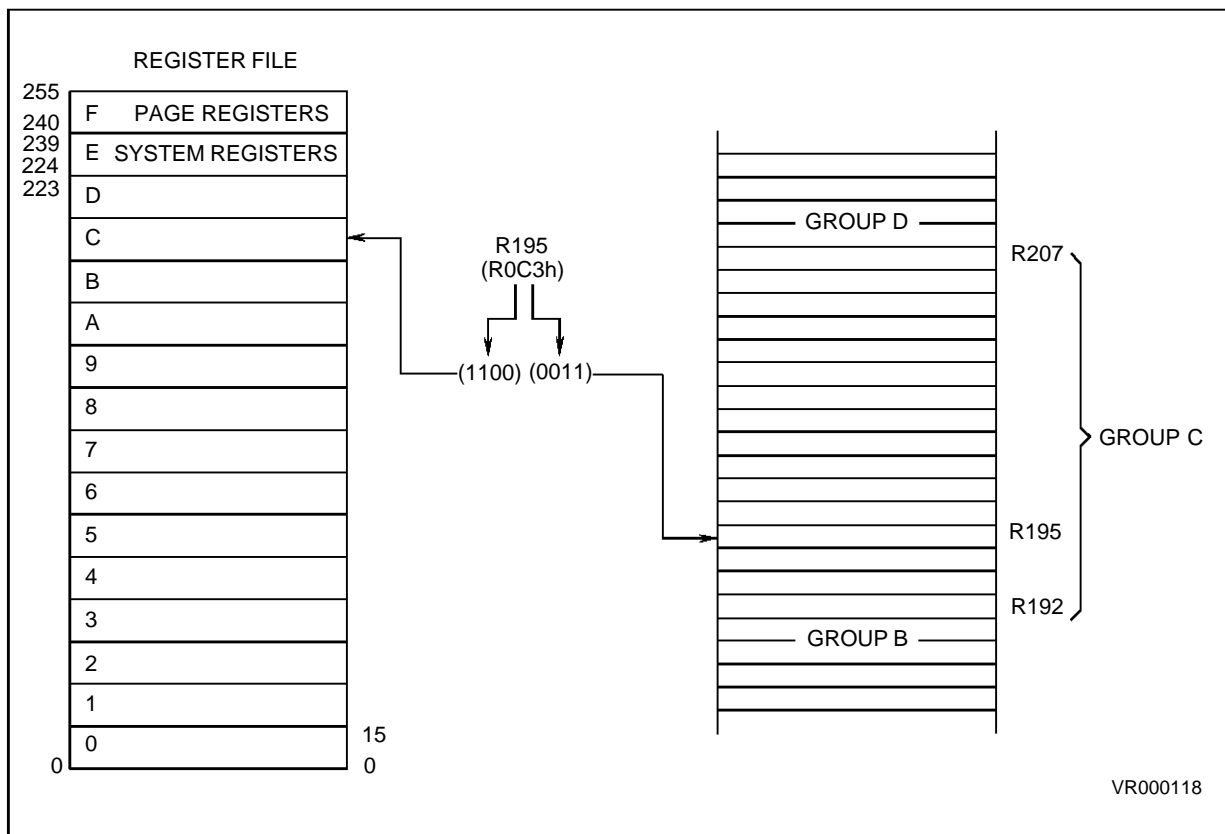

Figure 2-4. Addressing the Register File



ADDRESS SPACES (Continued)

2.2.2 Addressing Registers

All registers in the Register File and pages can be specified by using a decimal, hex or binary address, e.g. R231, RE7h or R11100111b is the same register.

The registers can be referred to by their hexadecimal group address, so that registers R0-R15 form group 0, R160-R175 form group A and so on.

Working Register Addresses

The 8-bit register address is formed by 2 nibbles, for example, for register R195 or RC3h or R11000011, 1100 specifies the 13th group (i.e. group C) and 0011 specifies the 3rd register in that group.

Working registers are addressed by supplying the least significant nibble in the instruction and adding it to the most significant nibble found in the Register Pointer (R233). Working register addressing is shown in Figures 2-4.

System Registers

The 16 system registers at addresses R224 to R239 form Group E.

The system registers are addressable using any of the 4 register addressing modes and the most significant nibble will, in all cases, be 14 (0Eh).

Paged Registers

There are a maximum of 64 pages each containing 16 registers. These are addressed using the register addressing modes with the addition of the Page Pointer register, R234. This register selects the page to be addressed in group F and once set, does not need to be changed if two or more registers on the same page are to be addressed in succession.

Therefore if the Page Pointer, R234, is set to 5, the instructions

```
spp 5
ld R242, r4
```

will load the contents of working register r4 into the third register (R242) of page 5.

These paged registers hold data and control registers related to the on-chip peripherals, and thus the configuration depends upon the peripheral organisation of each ST9 family member. i.e. pages only exist if the peripheral exists.

Available pages are shown in Table 2-2.

2.2.3 Input/Output Ports

The Input/Output ports are located in two areas. The port registers for Ports 0-5 are located at the bottom of the System register group in locations R224 to R229.

Each Port has three associated Control registers, which determine the individual pin modes (I/O, Open-Drain etc). These registers are located in pages 2 and 3.

Table 2-1. Register File Organization

Hex. Address	Decimal Address	Function	Register File Group
F0-FF	240-255	Paged Registers	Group F
E0-EF	224-239	System Registers	Group E
D0-DF	208-223	General Purpose Registers	Group D
C0-CF	192-207		Group C
B0-BF	176-191		Group B
A0-AF	160-175		Group A
90-9F	144-159		Group 9
80-8F	128-143		Group 8
70-7F	112-127		Group 7
60-6F	96-111		Group 6
50-5F	80-95		Group 5
40-4F	64-79		Group 4
30-3F	48-63		Group 3
20-2F	32-47		Group 2
10-1F	16-31		Group 1
00-0F	00-15	Group 0	

ST9 - Architecture (ST902x)

ADDRESS SPACES (Continued)

Table 2-2. Group F Peripheral Organization

Applicable for ST902x

DEC	DEC HEX	00 00	02 02	03 03	09 09	24 18	25 19
R255	RFF	RESERVED	PORT 3	RESERVED	RESERVED	MFT 0	RESERVED
R254	RFE	MSPI					
R253	RFD	WCR					
R252	RFC	T/W/D	PORT 2	RESERVED	RESERVED	MFT 0	SCI
R251	RFB						
R250	RFA						
R249	RF9	EXT INT	PORT 1	PORT 5	RESERVED	MFT 0	SCI
R248	RF8						
R247	RF7						
R246	RF6	RESERVED	PORT 0	RESERVED	MFT 0	MFT 0	SCI
R245	RF5						
R244	RF4						
R243	RF3	RESERVED	PORT 0	RESERVED	MFT 0	MFT 0	SCI
R242	RF2						
R241	RF1						
R240	RF0	RESERVED	PORT 0	RESERVED	MFT 0	MFT 0	SCI

2.3 SYSTEM REGISTERS

Following is the description of System Registers. For PORT0 to PORT5 Registers, please refer to I/O Port Chapter.

Figure 2-5. System Registers

R239 (EFh)	SYS. STACK POINTER LOW
R238 (EEh)	SYS. STACK POINTER HIGH
R237 (EDh)	USER STACK POINTER LOW
R236 (ECh)	USER STACK POINTER HIGH
R235 (EBh)	MODE REGISTER
R234 (EAh)	PAGE POINTER
R233 (E9h)	REGISTER POINTER 1
R232 (E8h)	REGISTER POINTER 0
R231 (E7h)	FLAGS
R230 (E6h)	CENTRAL INT. CNTL REG
R229 (E5h)	PORT5
R228 (E4h)	RESERVED
R227 (E3h)	PORT3
R226 (E2h)	PORT2
R225 (E1h)	PORT1
R224 (E0h)	PORT0

2.3.1 Central Interrupt Control Register

This Register CICR is located in the system Register Group at the address R230 (E6h). Please refer to “INTERRUPT” and “DMA” chapters in order to get the background of the ST9 interrupt philosophy.

CICR R230 (E6h) System Read/Write Central Interrupt Control Register

Reset Value : 1000 0111

7							0
GCEN	TLIP	TLI	IEN	IAM	CPL2	CPL1	CPL0

b7 = **GCEN**: *Global Counter Enable*. This bit is the Global Counter Enable of the Multifunction Timers. The GCEN bit is ANDed with the CE (Counter Enable) bit of the Timer Control Register (explained in the Timer chapter) in order to enable the Timers when both bits are set. This bit is set after the Reset cycle.

b6 = **TLIP**: *Top Level Interrupt Pending*. This bit is automatically set when a Top Level Interrupt Request is recognized. This bit can also be set by Software in order to simulate a Top Level Interrupt Request.

b5 = **TLI**: *Top Level Interrupt bit*. When this bit is set, a Top Level interrupt request is acknowledged depending on the IEN bit and the TLNM bit (in Nested Interrupt Control Register). If the TLM bit is reset the top level interrupt acknowledgement depends on the TLNM alone.

b4 = **IEN**: *Enable Interrupt*. This bit, (when set), allows interrupts to be accepted. When reset no interrupts other than the NMI can be acknowledged. It is cleared by interrupt acknowledgement for concurrent mode and set by interrupt return (*iret*). It can be managed by hardware and software (*ei* and *di* instruction).

b3 = **IAM**: *Interrupt Arbitration Mode*. This bit covers the selection of the two arbitration modes, the Concurrent Mode being indicated by the value “0” and the Fully Automatic Nested Mode by the value “1”. This bit is under software control.

b2-b0 = **CPL2-CPL0**: *Current Priority Level*. These three bits record the priority level of the interrupt presently under service (i.e. the Current Priority Level, CPL). For these priority levels 000 is the highest priority and 111 is the lowest priority. The CPL bits can be set by hardware or software and give the reference by which following interrupts are either left pending or able to interrupt the current interrupt. When the present interrupt is replaced by one of a greater priority, the current priority value is automatically stored until required.

SYSTEM REGISTERS (Continued)

2.3.2 Flag Register

The Flag Register contains 8 flags indicating the status of the ST9. During an interrupt the flag register is automatically stored in the system stack area and recalled at the end of the interrupt service routine so that the ST9 is returned to the original status. This occurs for all interrupts and, when operating in the nested mode, up to seven versions of the flag register may be stored.

FLAGR R231 (E7h) System Read/Write Flag Register

Reset value: undefined

7							0
C	Z	S	V	DA	H	UF	DP

b7 = **C**: *Carry Flag*. The carry flag C is affected by the following instructions:

Addition (*add, addw, adc, adcw*),
 Subtraction (*sub, subw, sbc, sbcw*),
 Compare (*cp, cpw*),
 Shift Right Arithmetic (*sra, srw*),
 Rotate (*rrc, rrcw, rlc, rlcw, ror, rol*),
 Decimal Adjust (*da*),
 Multiply and Divide (*mul, div, divws*).

When set, it generally indicates a carry out of the most significant bit position of the register being used as an accumulator (bit 7 for byte and bit 15 for word operations).

The carry flag can be set by the Set Carry Flag (*scf*) instruction, cleared by the Reset Carry Flag (*rcf*) instruction, and complemented (changed to "0" if "1", and vice versa) by the Complement Carry Flag (*ccf*) instruction.

b6 = **Z**: *Zero Flag*. The Zero flag is affected by the following instructions:

Addition (*add, addw, adc, adcw*),
 Subtraction (*sub, subw, sbc, sbcw*),
 Compare (*cp, cpw*),
 Shift Right Arithmetic (*sra, srw*),
 Rotate (*rrc, rrcw, rlc, rlcw, ror, rol*),
 Decimal Adjust (*da*),
 Multiply and Divide (*mul, div, divws*),
 Logical (*and, andw, or, orw, xor, xorw, cpl*),
 Increment and Decrement (*inc, incw, dec, decw*),
 Test (*tm, tmw, tcm, tcmw, btset*).

In most cases, the Zero flag is set when the register being used as an accumulator register is zero, following one of the above operations.

b5 = **S**: *Sign Flag*. The Sign flag is affected by the same instructions as the Zero flag.

The Sign flag is set when bit 7 (for byte operation) or bit 15 (for word operation) of the register used as an accumulator is one.

b4 = **V**: *Overflow Flag*. The Overflow flag is affected by the same instructions as the Zero and Sign flags.

When set, the Overflow flag indicates that a two's-complement number, in a result register, is in error, since it has exceeded the largest (or is less than the smallest), number that can be represented in twos-complement notation.

b3 = **DA**: *Decimal Adjust Flag*. The Decimal Adjust flag is used for BCD arithmetic. Since the algorithm for correcting BCD operations is different for addition and subtraction, this flag is used to specify which type of instruction was executed last, so that the subsequent Decimal Adjust (*da*) operation can perform its function correctly.

The Decimal Adjust flag cannot normally be used as a test condition by the programmer.

b2 = **H**: *Half Carry Flag*. The Half Carry flag indicates a carry out of (or a borrow into) bit 3, as the result of adding or subtracting two 8-bit bytes, each representing two BCD digits. The Half Carry flag is used by the Decimal Adjust (*da*) instruction to convert the binary result of a previous addition or subtraction into the correct BCD result.

Like the Decimal Adjust flag, this flag is not normally accessed by the user.

b1 = **UF**: *User Flag*. Bit 1 in the flag register (UF) is available to the user, but it must be set or cleared by an instruction.

b0 = **DP**: *Data/Program Memory Flag*. This bit in the flag register indicates which memory area is addressed. Its value is affected by the Set Data Memory (*sdm*) and Set Program Memory (*spm*) instructions.

If the bit is set, the ST9 addresses the Data Memory Area; when the bit is cleared, the ST9 addresses the Program Memory Area. By reading this bit, the user can verify in which memory area the processor is working. The user writes this bit with the *sdm* or *spm* instructions.

SYSTEM REGISTERS (Continued)

2.3.3 Register Pointing Techniques

Two registers, R232 and R233, within the system register group, are available for register pointing. R232 and R233 may be used together as a single pointer for a 16 register working space or separately for two 8 register spaces, in which case R232 becomes Register Pointer 0 (RP0) and R233 becomes Register Pointer 1 (RP1).

The instructions *srp*, *srp0* and *srp1* (the Set Register Pointer instructions) automatically inform the ST9 whether the RegisterFile is to operate with a single 16-register group or two 8-register groups. The *srp0* and *srp1* instructions automatically set the twin 8-register group mode while the *srp* instruction sets the single 16-register group mode. There is no limitation on the order or positions of these chosen register groups other than they must be on 8 or 16 register boundaries.

The addressing of working registers involves use of the Register Pointer value plus an offset value given by the number of the addressed working register.

When addressing a register, the most significant nibble (bits 4-7) gives the group address and the least significant nibble (bits 0-3) gives the register within that group.

REGISTER POINTER 0

RP0 R232 (E8h) System Read/Write Register Pointer 0

Reset Value : undefined

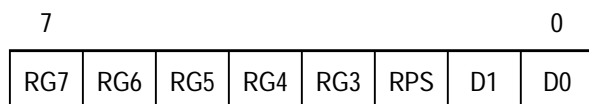

b7-b3 = **RG7-RG3**: *Register Group number*. These bits contain the number (from 0 to 31) of the group of working registers indicated in the instructions *srp0* or *srp*. When using a 16-register group, a number between 0 and 31 must be used in the *srp* instruction indicating one of the two adjacent 8-register group of working registers used. RG7 is the MSB.

b2 = **RPS**: *Register Pointer Selector*. This bit is set by the instructions *srp0* and *srp1* to indicate that a double register pointing mode is used. Otherwise, the instruction *srp* resets the RPS bit to zero to indicate that a single register pointing mode is used.

b1,b0 = **D1,D0**: These bits are fixed by hardware to zero and are not affected by any writing instruction trying to modify their value.

REGISTER POINTER 1

RP1 R233 (E9h) System Read/Write Register Pointer 1

Reset Value : undefined

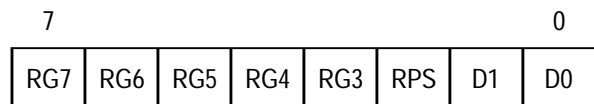

This register is used only with double register pointing mode; otherwise, using single register pointing mode, the RP1R register has to be considered as reserved and not usable as a general purpose register.

b7-b3 = **RG7-RG3**: *Register Group number*. These bits contain the number (from 0 to 31) of the group of 8 working registers indicated in the instructions *srp1*. Bit 7 is the MSB.

b2 = **RPS**: *Register Pointer Selector*. This bit is automatically set by the instructions *srp0* and *srp1* to indicate that a double register pointing mode is used. Otherwise the instruction *srp* reset the RPS bit to zero to indicate that a single register pointing mode is used.

b1,b0 = **D1,D0**: These bits are hardware fixed to zero and are not affected by any writing instruction trying to modify their value.

Note. If working in twin 8-register group mode but only using *srp0* (i.e. only using one 8-register group) the unused register (R233) is to be considered as reserved and not usable as a general purpose register.

The group of registers immediately below the system registers (i.e. group D, R208-R223) can only be accessed via the Register Pointers. To address group D then, it is necessary to set the Register Pointer to group D and then use the addressing procedure for working registers. The programmer is required to remember that the group D should be used as a stacking area. This point is also covered in the Stack Pointers paragraph.

SYSTEM REGISTERS (Continued)

EXAMPLES

Using the Single 16 Register Group

When the system is operating in the single 16-register group mode, the registers are referred to as r0-r15. In this mode, the offset value (i.e. the number of the working register referred to) is supplied in the address (preceded by a small r, e.g. r5) and is added to the Register Pointer 0 value to give the absolute address.

For example, if the Register Pointer contains the value 70h, then working register r7 would have the absolute address, R77h.

In this mode, the single 16-registers group will always start from the lowest even number equal or lower to the number given in the instruction.

Example: `srp #3` is equivalent to `srp #2`.

Using the Twin 8-Register Group

When working in the twin working group mode, the registers pointed by Register Pointer 0 (RP0R), are referred as r0-r7 and those pointed by Register Pointer 1 (RP1R), are referred to as r8-r15, regardless of their absolute addresses. In this mode, when operating with the first 8 working registers (i.e. r0 - r7) the working register number acts as an offset which is added to the value in Register Pointer 0.

So if Register Pointer 0 contains the value 96, then working register 0 has the absolute address 96, working register 5 has the absolute address 101, and so on. The second group of working registers, r8-r15, has the offset values 0 to 7 respectively (i.e. r8 has the offset value 0, r9 has the offset value 1, and so on), this offset value being added to the value in Register Pointer 1.

For example, given that the value in Register Pointer 1 is 32, then working register 12 supplies an offset value of 4 (given by 12 minus 8) to the value in Register Pointer 1 to give an absolute address of 36.

Figure 2-6. Single 16 Register pointing Mode

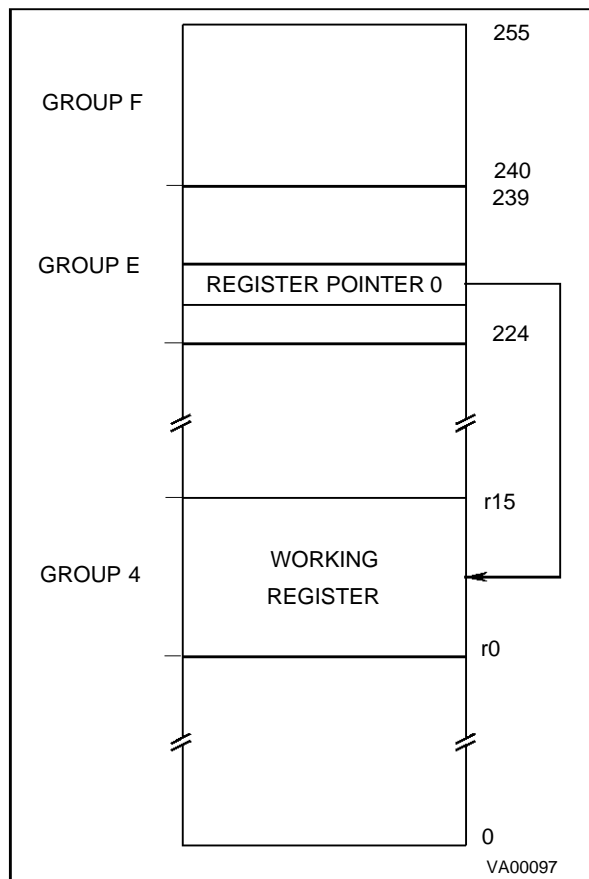
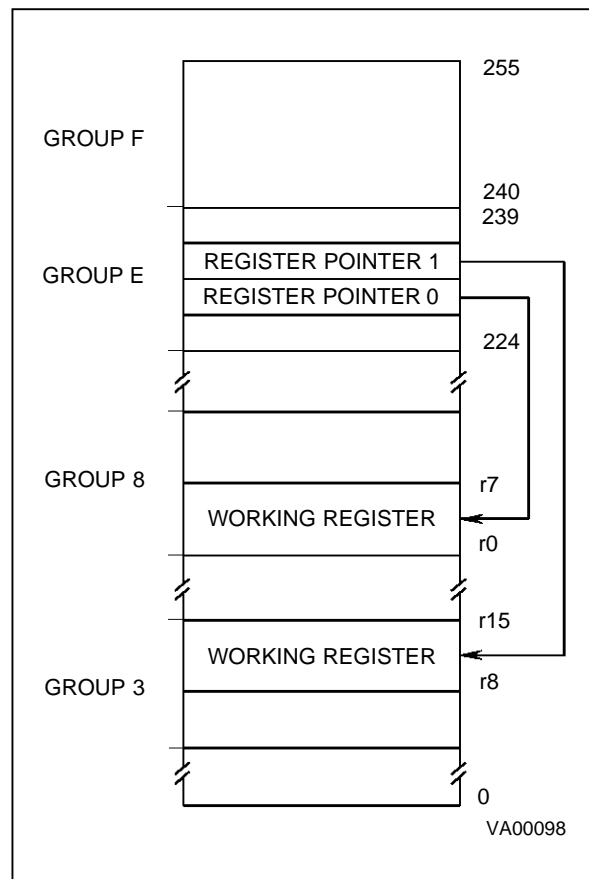

Figure 2-7. Double Register pointing Mode



SYSTEM REGISTERS (Continued)

2.3.4 Page Configuration

The pages are available to be used for the storage of control information (such as interrupt vector pointers) relevant to particular peripherals. There are up to 64 pages (each with 16 registers) based on registers R240-R255. These paged registers are addressable via the page pointer register (PPR), which is system register R234.

To address a paged register the page pointer register (R234) must be loaded with the relevant page number using the *spp* instruction (Set Page Pointer) and subsequently any address from the top (F) group (R240-R255) will be referred to that page.

For example if register 23 contains the value 44, the following sequence loads the third register R242 on page 5 with the value 44.

```
spp 5
ld R242, R23
```

PPR R234 (EAh) System Read/Write Page Pointer Register

Reset value : undefined

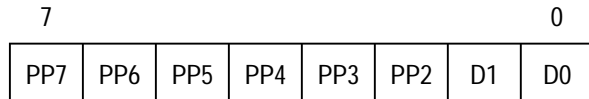

b7-b2 = **PP7-PP2**: *Page Pointer*. These bits contain the number (between 0 to 63) of the page chosen by the instruction *spp* (Set Page Pointer). PP7 is the MSB of the page address. Once the page pointer has been set, there is no need to refresh it unless a different page is required.

b1-b0 = **D1,D0**: These bits are fixed by hardware to zero and are not affected by any writing instruction trying to modify their value.

PAGE 0 contains the control registers of:

- the external interrupt
- the watchdog timer
- the wait logic states
- the serial peripheral interface (SPI)

2.3.5 Mode Registers

This register MODER is located in the System Register Group at the address 235.

Using this register it is possible:

- to select either internal or external System and User Stack area,
- to manage the clock frequency
- to enable the Bus request and Wait signals when interfacing external memory.

MODER R235 (EBh) System Read/Write Mode Register

Reset value : 1110 0000

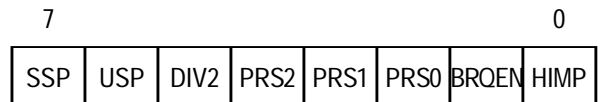

b7 = **SSP**: *System Stack Pointer*. This bit selects internal (in the Register File) or external (in the external Data Memory) System Stack area, logical "1" for internal, and logical "0" for external. After Reset the value of this bit is "1".

b6 = **USP**: *User Stack Pointer*. Same as bit 7 for the User Stack Pointer;

b5 = **DIV2**: *OSCIN Clock Divided by 2*. This bit controls the divide by 2 circuit which operates on the OSCIN Clock. A logical "1" value means that the OSCIN clock is internally divided by 2, and a logical "0" value means that no division of the OSCIN Clock occurs.

b4-b2 = **PRS2-PRS0**: *ST9 CPUCLK Prescaler*. These bits load the prescaling module of the internal clock (INTCLK). The prescaling value selects the frequency of the ST9 clock, which can be divided by 1 to 8. See Clock chapter for more information.

b1 = **BRQEN**: *Bus Request Enable*. This bit is a software enable of an External Bus Request. When set to "1", it enables a Bus Request on the BUSREQ pin.

b0 = **HIMP**: *High Impedance Enable*. When Port 0 and/or Port 1 are programmed as multiplexed address and Data lines to interface external Program and/or Data Memory, these lines and the Memory interface control lines (\overline{AS} , \overline{DS} , R/\overline{W}) can be forced into the High Impedance state by setting to "1" the HIMP bit. When this bit is reset, it has no effect on P0 and P1 lines.

If Port 1 is declared as an address AND as an I/O port (example: P10 ... P14 = Address, and P15 ... P17 = I/O), HIMP has no effect on the I/O lines (in the previous example: P15 ... P17).

SYSTEM REGISTERS (Continued)

2.3.6 Stack Pointers

There are two separate, double register stack pointers available (named System Stack Pointer and User Stack Pointer), both of which can address registers or memory.

The stack pointers point to the bottom of the stacks which are filled using the `push` commands and emptied using the `pop` commands. The stack pointer is automatically pre-decremented when data is “pushed in” and post-incremented when data is “popped out”.

For example, the register address space is selected for a stack and the corresponding stack pointer register contains 220. When a byte of data is “pushed” into the stack, the stack pointer register is decremented to 219, then the data byte is “loaded” into register 219. Conversely, if a stack pointer register contains 189 and a byte of data is “popped” out, the byte of data is then extracted from the stack and then the stack pointer register is incremented to 190.

The `push` and `pop` commands used to manage the system stack area are made applicable to the user stack by adding the suffix `U`, while to use a stack instruction for a word a `W` is added.

For example `push` inserts data into the system stack, but an added `U` indicates the user stack and `W` means a word, so the instruction `pushuw` loads a word into the bottom of the user stack.

If the User Stack Pointer register contains 223 (working in register space) the instruction `pushuw` will decrement User Stack Pointer register to 222 and then load a word into register R222 and R221.

When bytes (or words) are “popped out” the values in those registers are left unchanged until fresh data is loaded into those locations. Thus when data is “popped” out from a stack area, the stack content remains unchanged.

Note. Stacks must not be located in the pages or the system register area.

The System Stack area and The System Stack Pointer

The System Stack area is used for the storage of temporarily suspended system and/or control registers, i.e. the Flag register and the Program counter, while interrupts are being serviced. For subroutine execution only the Program Counter needs to be saved in the System stack area.

There are two situations when this occurs automatically, one being when an interrupt occurs and the other when the instruction call subroutine is used. When the system stack area is in the Register File, the stack pointer, which points to the bottom of the stack, only needs one byte for addressing, in which case the System Stack Pointer Low Register (R239) is sufficient for addressing purposes. As a result the System Stack Pointer High Register (R238) becomes redundant BUT must be considered as reserved (please refer also to “spurious” memory access section). Clearly when the stack is external a full word address is necessary and so both registers are used to point, the even register providing the MSB and the odd register providing the LSB.

The User Stack area and User Stack Pointer

The User Stack area is completely free from all interference from automatic operations and so it provides a totally user controlled stacking area, that area being in any part of the memory which is of a RAM nature, or the first 14 groups of the general Register File i.e. not in the System register or Paged group.

The User Stack Pointer consists of two registers, R236 and R237, which are both used for addressing an external stack, while, when stacking in the Register File, the User Stack Pointer High Register, R236, becomes redundant but must be considered as reserved.

SYSTEM REGISTERS (Continued)

Stack location

Care is necessary when managing stacks as there is no limit to stack sizes apart from the bottom of any address space in which the stack is placed. Consequently programmers are advised to use a stack pointer value as high as possible, particularly when using the Register File as a stacking area. This will also benefit programmers who may locate the stacks in group D using, for example the instruction `ld R237, #223` which loads the value

223 into the User Stack Pointer Low Register. The Programmer will not need to remember to set the Register Pointer to 208 to gain access to registers in the D-group, a problem outlined in Register Pointing Techniques paragraph.

Stacks may be located anywhere in the first 14 groups of the Register File (internal stacks) or the data memory (external stacks). It is not necessary to set the data memory using the instruction `sdm` as external stack instructions automatically use the data memory.

Figure 2-8. System and/or User Stack in Register Stack Mode

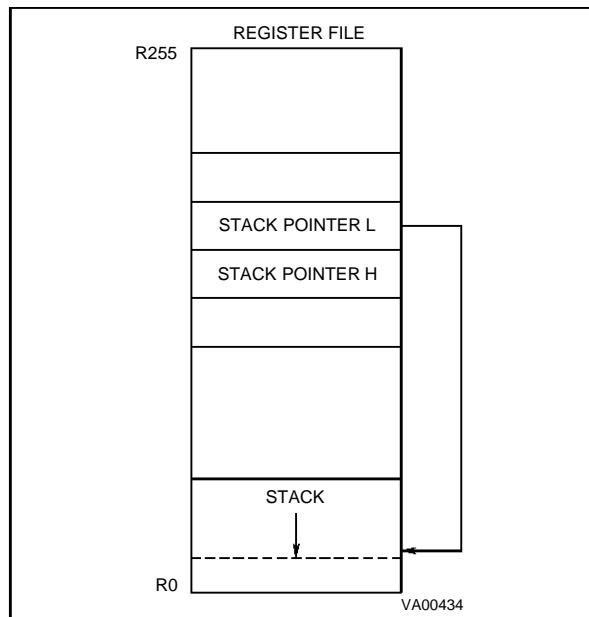
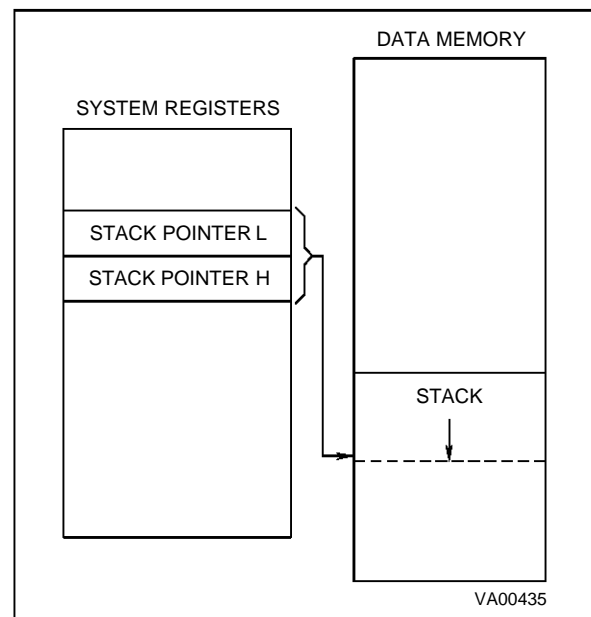

Figure 2-9. System and/or User Stack in Memory Stack Mode



USP R236 (ECh) System Read/Write
User Stack Pointer High Byte

Reset value: undefined

7							0
USP15	USP14	USP13	USP12	USP11	USP10	USP9	USP8

SSP R238 (EEh) System Read/Write
System Stack Pointer High Byte

Reset value: undefined

7							0
SSP15	SSP14	SSP13	SSP12	SSP11	SSP10	SSP9	SSP8

USP R237 (EDh) System Read/Write
User Stack Pointer Low Byte

Reset value: undefined

7							0
USP7	USP6	USP5	USP4	USP3	USP2	USP1	USP0

SSP R239 (EFh) System Read/Write
System Stack Pointer Low Byte

Reset value: undefined

7							0
SSP7	SSP6	SSP5	SSP4	SSP3	SSP2	SSP1	SSP0

ST9 - Architecture (ST902x)

Notes :

3 MEMORY

3.1 INTRODUCTION

The memory of the ST902x is divided into two spaces:

- Data memory with up to 64K bytes
- Program memory with up to 64K bytes

Thus, there is a total of 128K bytes of addressable memory space.

The 12/16K bytes of on-chip ROM memory of the ST902x are selected at memory addresses 0 through 2FFFh (hexadecimal) in the PROGRAM space.

The DATA space includes the 256 bytes of on-chip RAM memory at addresses 0000h through 00FFh (ST9027, ST9028 only).

Off-chip data memory, addressed using the multiplexed address and data buses (Ports 0 and 1) may be divided into the Program and Data spaces by the external decoding of the Program/Data select pin (P/D) available as an Alternate function output.

The memory spaces are selected by the execution of the `sdm` and `spm` instructions (Set Data Memory and Set Program Memory, respectively). There is no need to use either of these instructions again until the memory area required is to be changed. This requirement is not necessary in two cases: first, when operating with external stacks (the Data memory is automatically selected) and, secondly, when using the memory indirect to memory indirect post-increment addressing mode (the memory types are specified in the instructions: `ldpp`, `ldpd`, `lddp`, `lddd`).

Program instructions and data in the immediate addressing mode are always read from the Program space. For example:

```
sdm
ld R80,#99
```

will load R80 with the value 99 decimal from the program space.

Figure 3-1. Memory Map

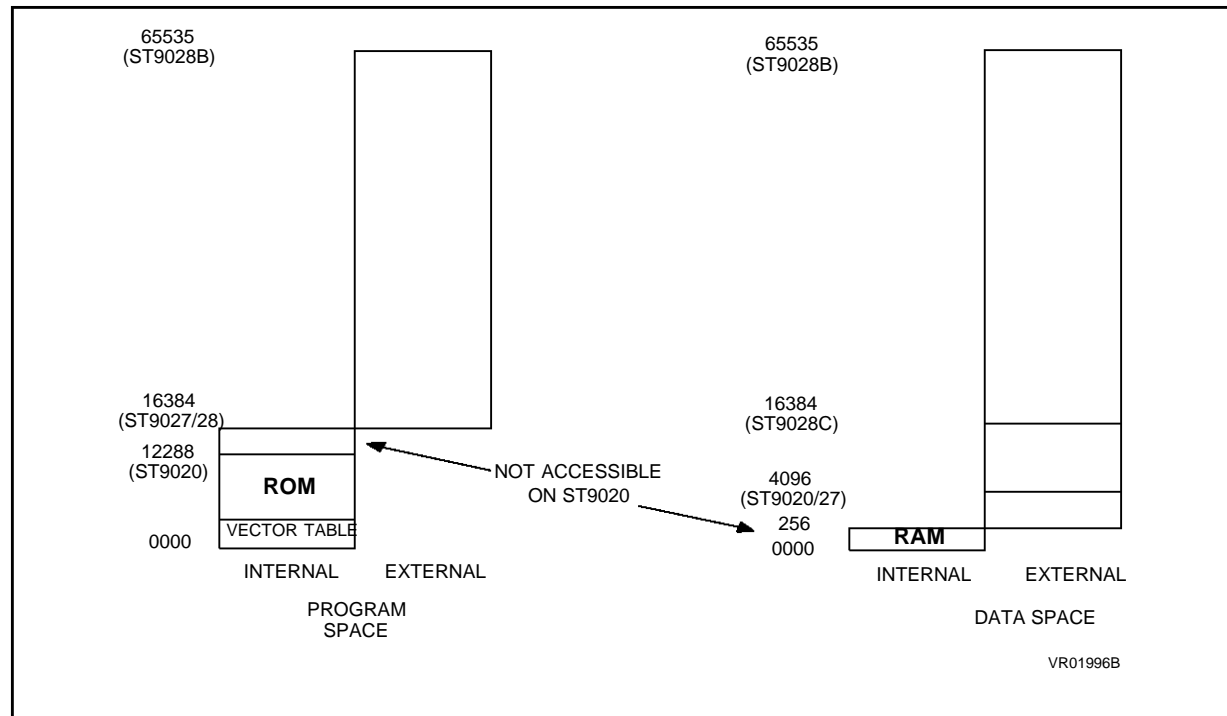

ST9 - Memory

Either the Data Memory or the Program Memory, both external or internal, can be addressed using any of the memory addressing modes.

The 16-bit memory address may be supplied directly using the absolute memory location address or indirectly using a pair of registers. In addition the address can be given by an indexed mode when a short (byte) or long (word) offset is added to an indirect base word address.

Table 3-1. First 6 Bytes of Program Space

0	Address high of Power on Reset routine
1	Address low of Power on Reset routine
2	Address high of Divide by zero trap Subroutine
3	Address low of Divide by zero trap Subroutine
4	Address high of Top Level Interrupt routine
5	Address low of Top Level Interrupt routine

3.2 PROGRAM SPACE DEFINITION

The Program memory space of the ST902x, from the 16K bytes of on-chip ROM memory to the full 64K bytes with off-chip memory expansion, is available to the user on the ST9028B. At addresses greater than the first 16K bytes of program space, the ST9028B executes external memory cycles for instruction fetches.

The first 256 memory locations from address 0 to FFh hold the Reset Vector, the Top-Level (Pseudo Non-Maskable) interrupt, the Divide by Zero Trap

Routine vector and, optionally, the interrupt vector table for use with the on-chip peripherals and the external interrupt sources. Apart from this case no other part of the Program memory has a predetermined function.

Each vector is contained in two consecutive byte locations, the high order address held in the lower (even) byte, the low order address held in the upper (odd) byte, forming the address which is loaded into the Program Counter when selected by the interrupt vector provided by the interrupt source. This should point to the relevant Interrupt Service routine provided by the user for immediate response to the interrupt.

3.3 DATA SPACE DEFINITION

The ST9027, 28 addresses the 256 bytes of on-chip RAM memory from addresses 0000 to 255 (0000h to 00FFh). It may also address up to 16K locations of External Data through the External Memory Interface when decoded with the P/ \bar{D} pin. The on-chip general purpose registers may be used as additional RAM memory for minimum chip count systems.

The Data Space is selected by the execution of the `sdm` instruction. All subsequent operand and stack memory references will access the Data Space.

When a separate Data Space is not provided, data may also be stored in external RAM or ROM memory within the Program Space.

4 INTERRUPTS

4.1 INTRODUCTION

The ST9 responds to peripheral events and external events through its Interrupt channels. When such an event occurs, if previously enabled and according to a priority mechanism, the current program execution can be suspended to allow the ST9 to execute a specific response routine. If the event generates an interrupt request, the current program status is saved after the current instruction is completed and the CPU control passes to the Interrupt Service Routine.

The ST9 CPU can receive requests from the following type of sources:

- On-chip peripherals
- External pins
- Top-Level Pseudo-non-maskable interrupt

According to the on-chip peripheral features, an event occurrence can generate an Interrupt request depending on the selected mode.

Up to eight external interrupt channels, with programmable input trigger edge, are available. In addition, a dedicated interrupt channel, set to the Top-level priority, can be devoted either to the external pin NMI (to provide a Non-Maskable-Interrupt) or to the Timer/Watchdog. Interrupt service routines are addressed through a vector table mapped in Program Memory.

Figure 4-1. Interrupt Flow

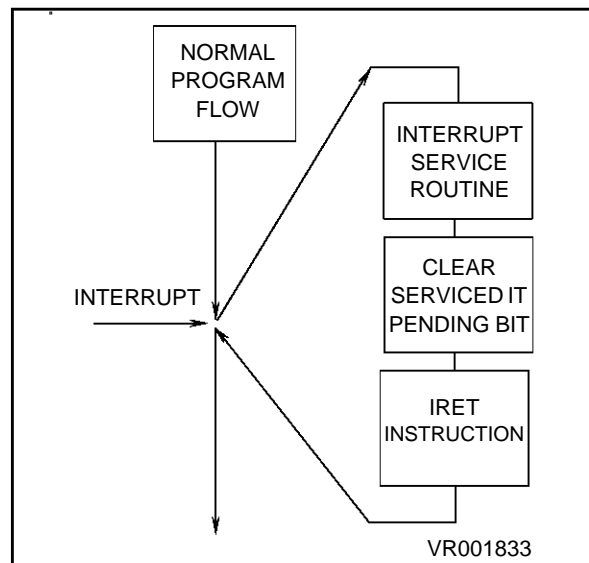

4.2 INTERRUPT VECTORIZATION

The ST9 implements an interrupt vectoring structure that allows the on-chip peripheral to identify the location of the first instruction of the Interrupt Service Routine (IVR) automatically.

When the interrupt request is acknowledged, the peripheral interrupt module provides, through its Interrupt Vector Register (IVR), a vector to point into the vector table of locations containing the start addresses of the Interrupt Service Routines (defined by the programmer).

Each peripheral has a specific IVR mapped within its Register File pages.

The Interrupt Vector table, containing the list of the addresses of the Interrupt Service Routines, is located in the first 256 locations of the Program Memory. The first 6 locations of the Program Memory are reserved for:

Address Content

0	Address high of Power on Reset routine
1	Address low of Power on Reset routine
2	Address high of Divide by zero trap Subroutine
3	Address low of Divide by zero trap Subroutine
4	Address high of Top Level Interrupt routine
5	Address low of Top Level Interrupt routine

With one Interrupt Vector register, it is possible to address more interrupt service routines; in fact, several peripherals share the same interrupt vector register among several interrupt channels. The most significant bits of the vector are user programmable to define the base vector address inside the vector table in the program memory, the least significant bits are controlled by the interrupt module in hardware to select the specific vector.

Note: The first 256 locations of the program memory can contain program code. Other than the Reset vector, they are not exclusively reserved to the vector table.

Warning. Although the Divide by Zero Trap operates as an interrupt, the FLAG Register is not pushed onto the system Stack automatically. As a result it must be regarded as a subroutine, and the acknowledge routine must end with the RET instruction.

INTERRUPT VECTORIZATION (Continued)

Figure 4-2. Vectors and Associated Routines

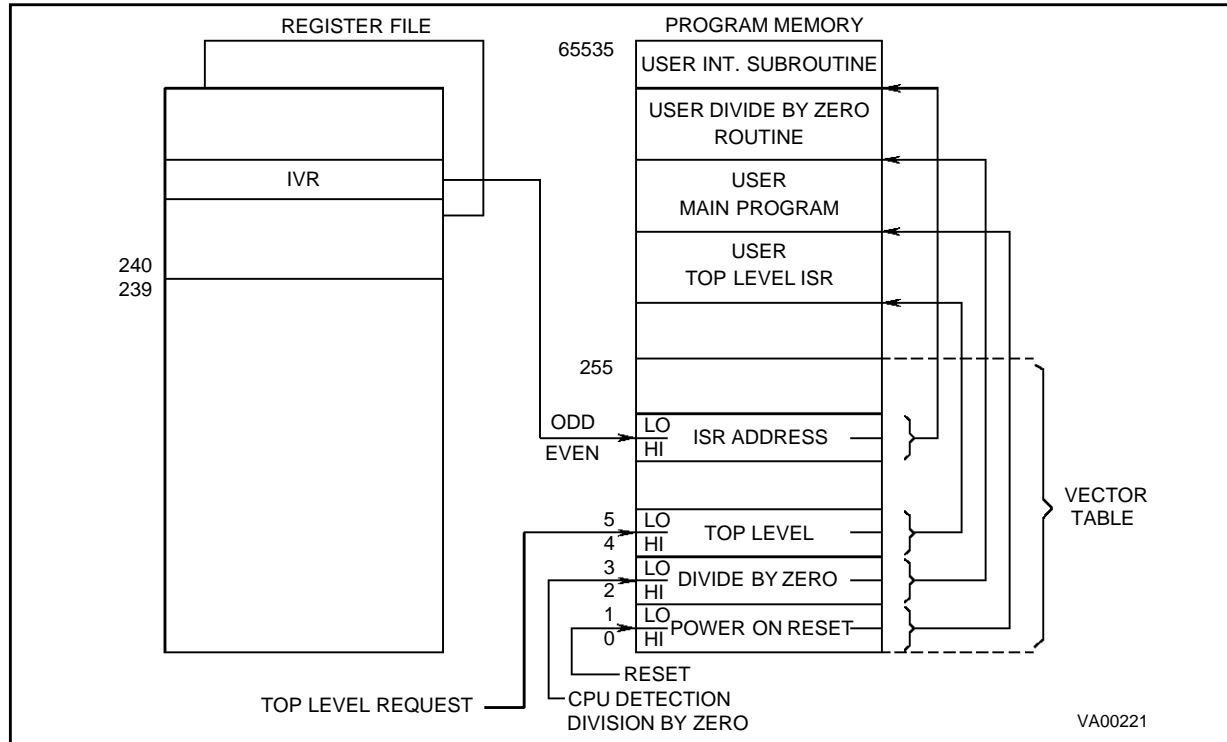
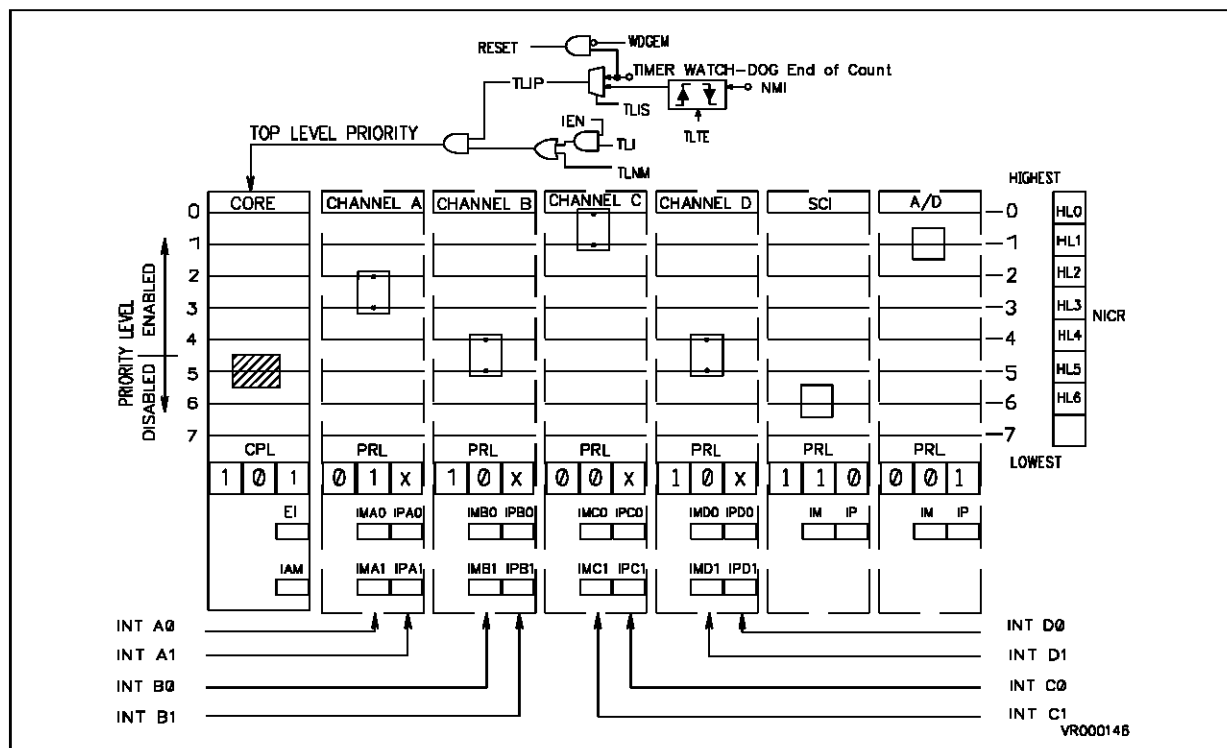

Figure 4-3. Interrupt Architecture, Example of priority Allocations



4.3 INTERRUPT PRIORITY LEVEL ARCHITECTURE

The ST9 supports a fully programmable interrupt priority structure. Figure 4-4 shows a conceptual description.

9 priority levels are available to define the channel priority relationship. Each channel has a 3 bit field, PRL (Priority Level), that defines its priority level among 8 programmable levels. The ninth level (Top Level Priority) is reserved for the Timer/Watchdog or the External Pseudo Non-Maskable Interrupt. The On-chip peripheral channel and the eight external interrupt sources can be programmed within eight priority levels: level 7 has the lowest priority, level 0 has the highest priority.

If several units are located at the same priority level, an internal daisy chain, fixed for each ST9 device, defines the priority relationship within that level.

The PRL bits are used to define the priority level for interrupt requests.

Top level priority interrupt (highest) can be assigned either to the external Pseudo Non-Maskable interrupt or to the internal Timer/Watch-Dog. An Interrupt service routine at this level cannot be interrupted in any arbitration mode. Its mask can be both maskable (TLI) or non-maskable (TLNM).

4.4 PRIORITY LEVEL ARBITRATION

The 3 bits of CPL (Current Priority Level) in the Central Interrupt Control Register contain the priority of the currently running program (CPU priority). CPL is set to 7 (lowest priority) upon reset and can be modified during program execution either by software or automatically by hardware according to the selected Arbitration Mode.

During every instruction an arbitration phase is made between every channel capable of generating an Interrupt, each priority level is compared to all the other requests. If the highest priority request is an interrupt, it must be *higher* than the CPL value in order to be acknowledged.

The priority of the Top Level Interrupt overrides every other priority.

If two or more requests occur at the same instant of time and at the same priority level, an on-chip daisy chain, specific to every ST9 version, selects the channel with the highest position in the chain. The position in the chain is shown in table 4-1.

ST9 provides two interrupt arbitration modes: Concurrent and Nested modes. The Concurrent mode is the standard interrupt arbitration mode while the Nested mode improves the effective interrupt response time when a nesting of the service routines is required according to the request priority levels.

Figure 4-4. Interrupt Logic

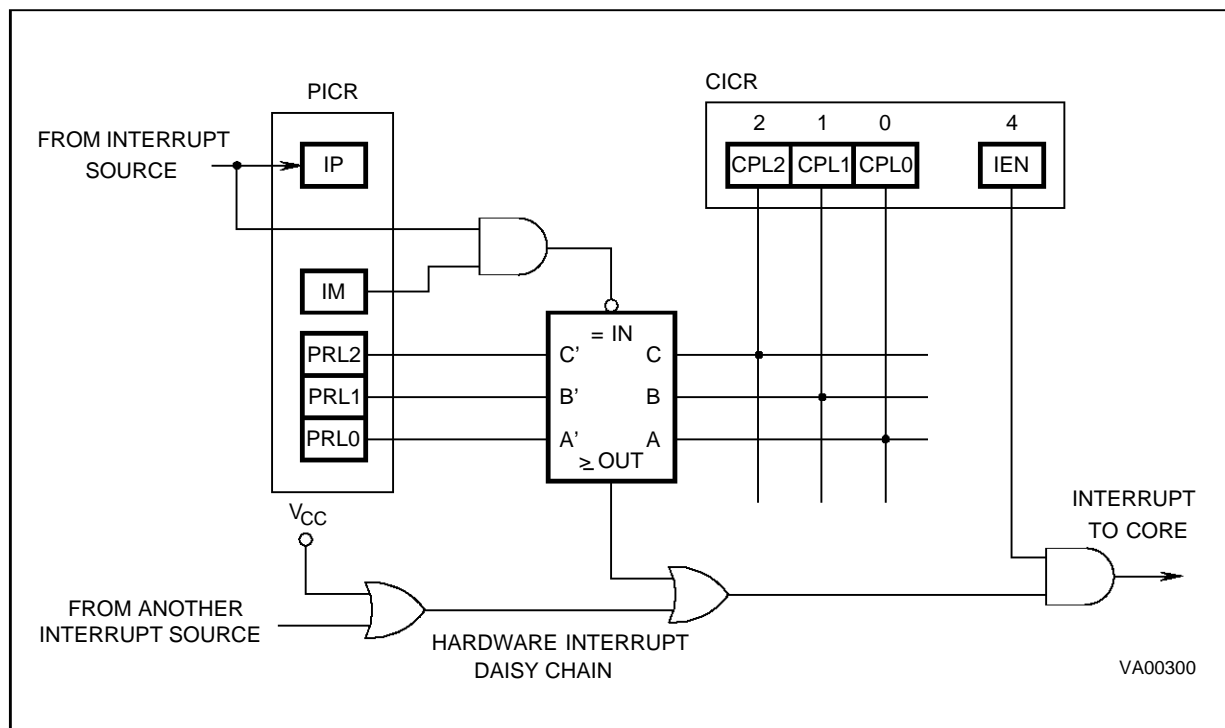

ST9 - Interrupts (ST902x)

PRIORITY LEVEL ARBITRATION (Continued)

The control bit IAM (CICR.3) selects the Concurrent Arbitration mode (when reset to "0") or the Nested Arbitration Mode (when set to "1").

Table 4-1. Daisy Chain Priorities

Applicable for ST902x

Highest Position	INTA INTB INTC INTD MFTIMER0
Lowest Position	SCI

4.4.1 Concurrent Mode

This mode is selected when the IAM bit is cleared (reset condition). The arbitration phase, performed during every instruction, selects the request with the highest priority level.

If the highest priority request is an interrupt request and its priority value is higher than the Current Priority Value CICR.2,1,0 (R230.2,1,0), the interrupt request will be acknowledged at the end of the current instruction. The interrupt Machine Cycle performs the following steps:

- 1. Disables all the maskable interrupt requests by clearing CICR.IEN
- 2. Pushes the PC low byte into the system stack
- 3. Pushes the PC high byte into the system stack
- 4. Pushes the Flag register into the system stack
- 5. Loads the PC with the 16-bit vector stored in the Vector Table, pointed to by the Interrupt Vector Register (IVR).

Figure 4-5. Example of a Sequence of Interrupt Requests with :
 - Concurrent mode
 - EI set to 1 during the interrupt routine execution

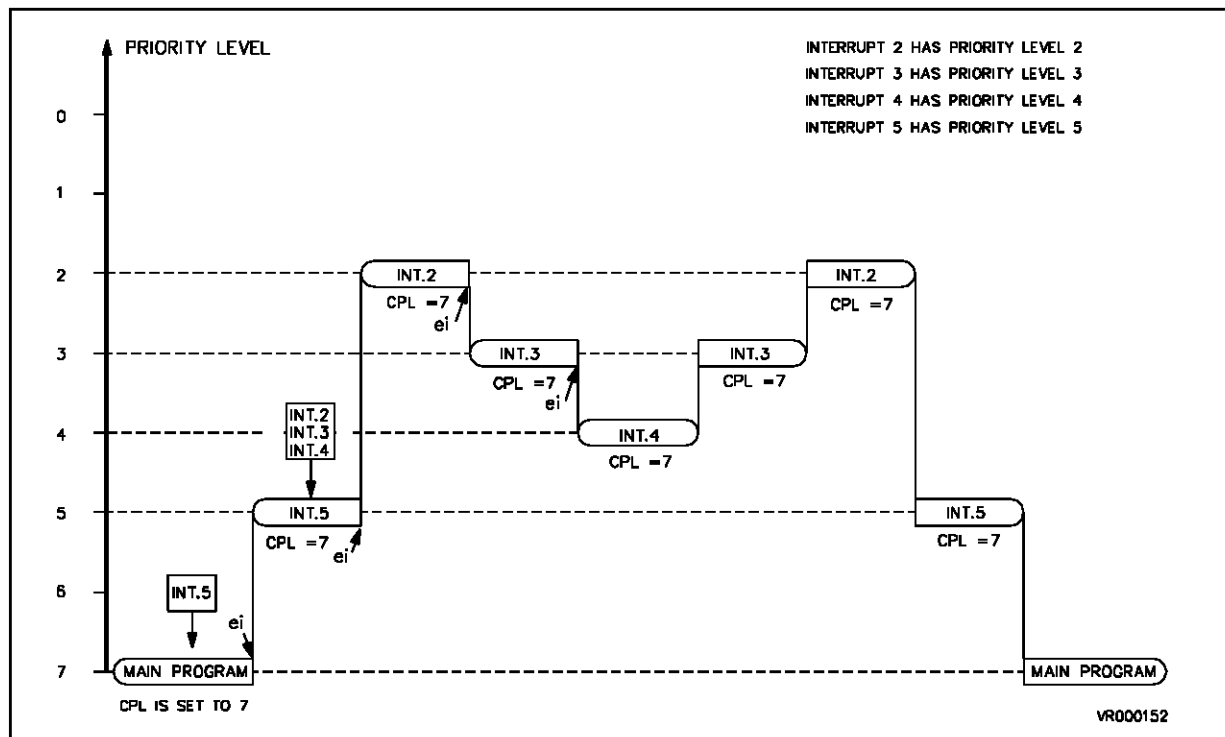

PRIORITY LEVEL ARBITRATION (Continued)

The Interrupt Service Routine must be concluded with the `iret` instruction. The `iret` instruction executes the following operations:

- 1. Pops off the Flag register from the system Stack
- 2. Pops off PC high byte from the system Stack
- 3. Pops off PC low byte from the system Stack
- 4. Enables all the un-masked Interrupts, by setting the CICR.IEN bit

The suspended program execution is thus recovered at the interrupted instruction. All pending interrupts existing, or having occurred during the interrupt service routine execution, remain pending until the Enable Interrupt instruction (even if it is executed during the interrupt service routine).

NOTE: When Concurrent mode is selected, the source priority level is meaningful only during the arbitration phase, where it is compared to all the other priority levels and the CPL, but no trace is kept of its value during the Interrupt Service Routine. Therefore, if other requests are issued, once the global CICR.IEN is enabled again, they will be acknowledged regardless of the Interrupt Service Routine priority value; if no care is taken by the programmer, unpleasant side effects can take place.

A typical case is the following: 3 pending requests with different priority levels (ie 2,3,4) generate requests at the same time (because the associated events occurred during the same instruction). The three interrupt service routines set Interrupt Enable (IEN, CICR.4) by the `ei` instruction at the beginning of the routine to avoid a high interrupt response time to requests with a priority higher than the one under service (usually, the higher the priority, the sooner the routine must be executed). Unfortunately, what will happen in this case is that the three interrupt servicing routines will be executed exactly in the opposite order of their priority. Interrupt routine level 2 will be acknowledged first, then, when the `ei` instruction is executed, it will be interrupted by interrupt routine level 3, which itself will be interrupted by interrupt routine level 4. When interrupt routine level 4 is completed, interrupt routine level 3 will be recovered and finally, interrupt routine level 2.

Therefore, **it is recommended, in concurrent mode, to avoid the insertion of the `ei` instruction in the interrupt subroutine**, which can trigger this LIFO (Last In, First Out) sequence of interrupt processing.

Figure 4-6. Example of a Sequence of Interrupt Requests with :
 - Concurrent mode
 - EI unchanged by the interrupt routines

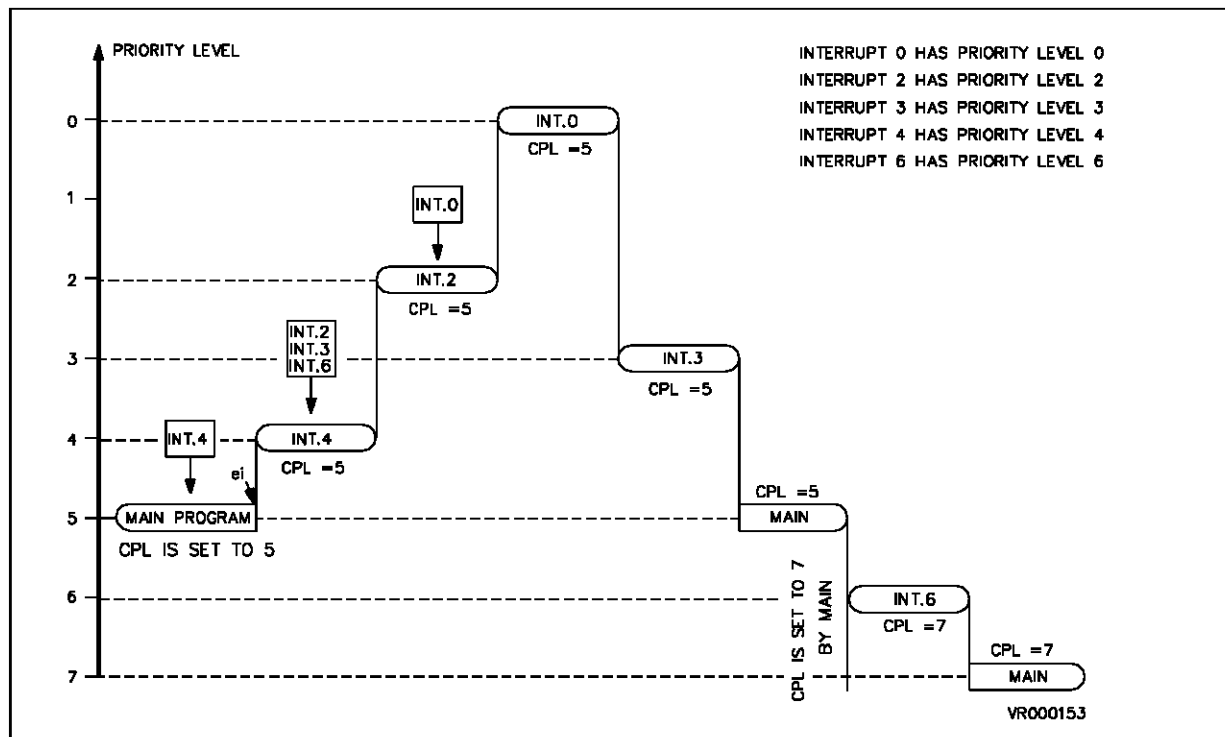

PRIORITY LEVEL ARBITRATION (Continued)

Figure 4-7. Interrupt Mode Flow-Chart

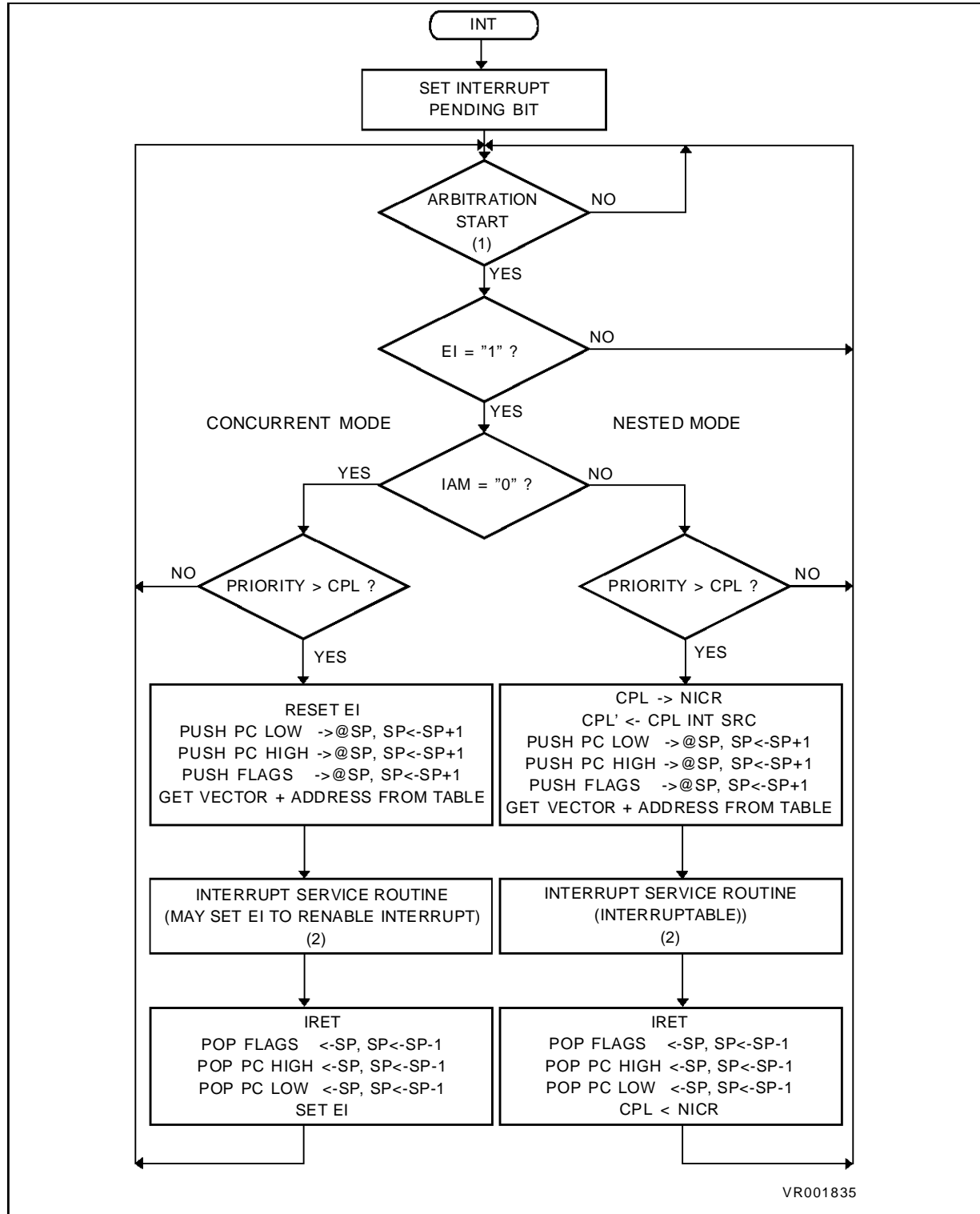

VR001835

Notes:

1. The interrupt arbitration starts 6 CPUCLK cycles before the end of execution of each instruction (5 cycles during WFI).
2. Clear interrupt pending bit

PRIORITY LEVEL ARBITRATION (Continued)

4.4.2 Nested Mode

The difference of the Nested mode to the Concurrent mode consists of the modification of the CPL value during the interrupt processing. The arbitration phase is basically identical to the concurrent Mode, however once the request is acknowledged, the current CPL value is saved in the Nested Interrupt Control Register (NICR, R247 page 0) by setting the NICR bit corresponding to the CPL value (i.e. if the CPL is 3, NICR.3 bit will be set). The CPL value is then updated with the Priority value of the request just acknowledged, in this way the next arbitration cycle will be performed against the priority level of the Service Routine in progress.

The Interrupt Machine Cycle will perform the following steps:

- Disable all the maskable interrupts by clearing IEN
- Save the CPL value into the special stack NICR to hold the priority level of the suspended routine
- Store in CPL the priority level of the acknowledged routine, so that the next request priority will be compared with the one of the routine under service
- Push the PC-low byte into the System Stack
- Push the PC-high byte into the System Stack
- Push the Flag Register into the System Stack

Figure 4-8. Example of a Sequence of Interrupt Requests with :
- Nested mode
- EI set to 1 during the interrupt routine execution

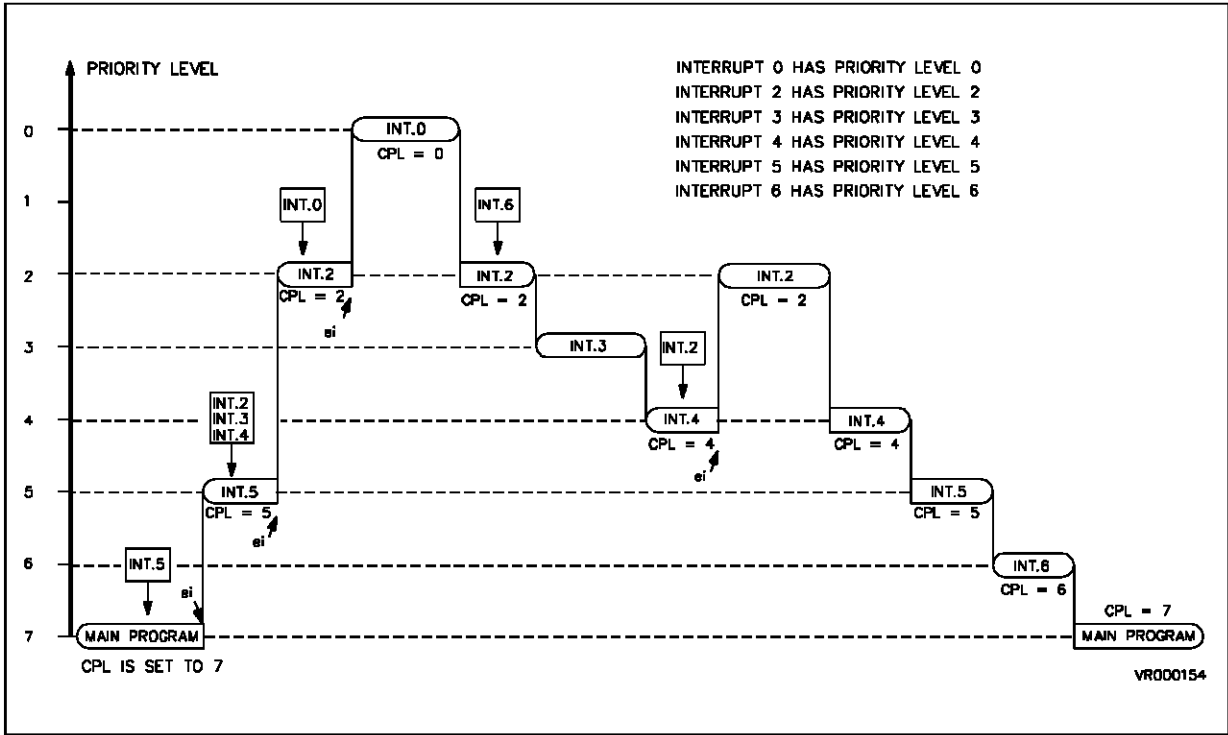

ST9 - Interrupts (ST902x)

PRIORITY LEVEL ARBITRATION (Continued)

- Load the PC with the vector pointed by IVR.
- The `iret` Interrupt Return instruction executes the following steps:
1. Pop off the Flag Register from the System Stack
 2. Pop off the PC-high byte from the System Stack
 3. Pop off the PC-low byte from the System Stack
 4. Enable all the unmasked interrupts by setting the IEN bit
 5. Recover the interrupted routine priority level by popping the value from the special register (NICR) and by copying it into CPL.

The suspended execution is thus recovered at the interrupted instruction.

REMARKS

1) Dynamic priority level modification: the main program and routines can be specifically prioritized. Since CPL is represented by 3 bits in a read/write register, it is possible to modify dynami-

cally the current priority value during the program execution. This means that a critical section can have a higher priority with respect to other interrupt requests. Furthermore it is possible to prioritize even the Main Program execution by modifying CPL during its execution.

2) Maximum number of nestings: No more than 8 routines can be nested. If an interrupt routine at level N is being serviced, no other Interrupts located at level N can interrupt it. This guarantees a maximum number of 8 nested levels including the Top Level Interrupt request.

3) Priority level 7: Interrupt requests at level 7 cannot be acknowledged as their priority cannot be higher than the CPL value. This can be of use in a fully polled interrupt environment.

A nested/concurrent mode sequence is given on Figure 4-10. This example clearly shows that Nested and Concurrent modes are defined by the user. Note that here the Y axis is referenced by CPL, instead of the source priority level, and *that Interrupt 1 stays pending*, having a priority level lower than CPL.

Figure 4-9. Example of a Sequence of Interrupt Requests with :
 - Nested mode
 - EI unchanged by the interrupt routiness

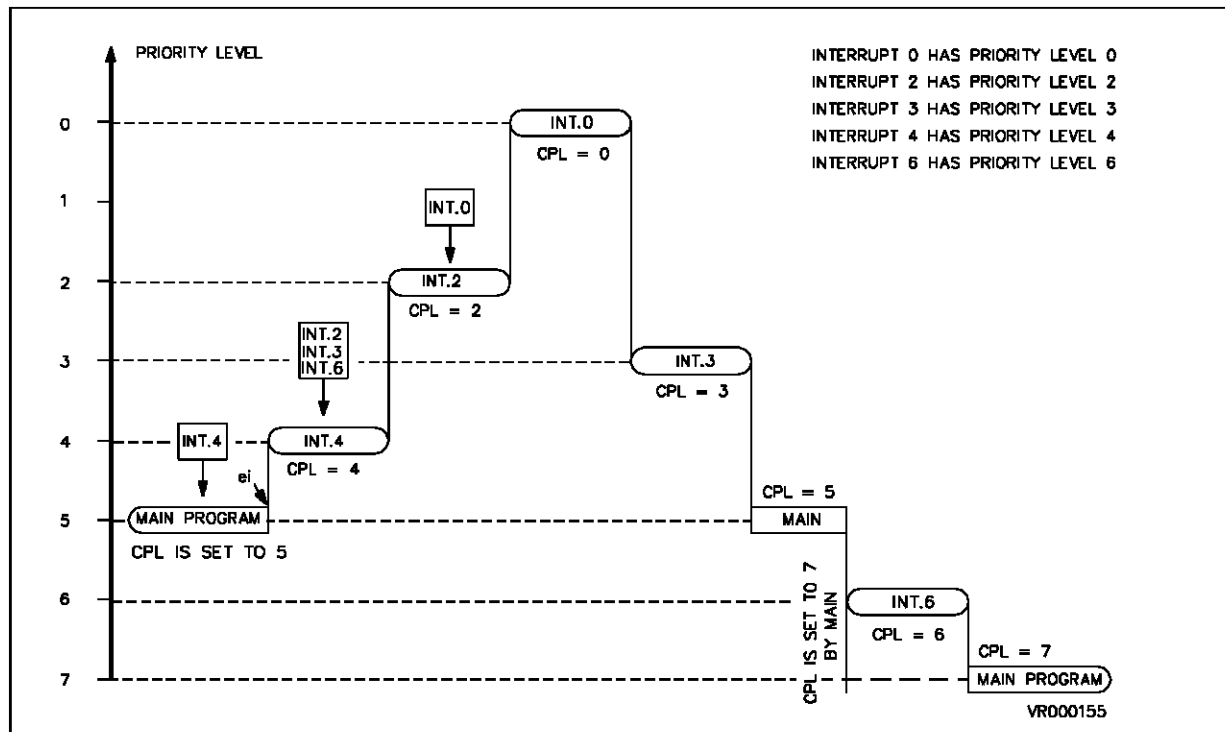

PRIORITY LEVEL ARBITRATION (Continued)

Figure 4-10. Example of a Nested and Concurrent Mode Sequence

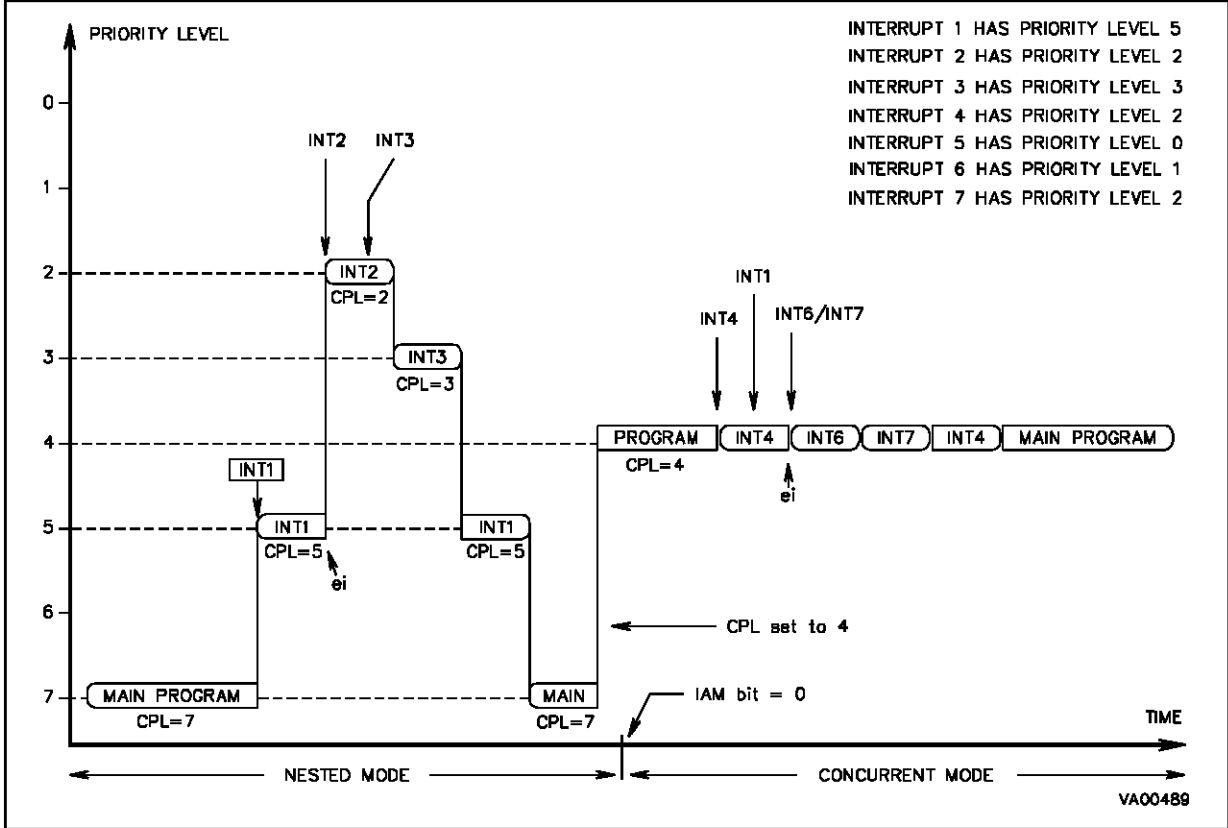

4.5 EXTERNAL INTERRUPTS

The standard ST9 core contains 8 external interrupts sources grouped into four pairs.

Table 4-2. External Interrupt Channel Grouping

External Interrupt	Channel
INT7 INT6	INTD1 INTD0
INT5 INT4	INTC1 INTC0
INT3 INT2	INTB1 INTB0
INT1 INT0	INTA1 INTA0

Each source has a trigger control bit TEA0,..TED1 (R242,EITR.0,..,7 Page 0) to select triggering on the rising or falling edge of the external pin. If the Trigger control bit is set to "1", the corresponding pending bit IPA0,..,IPD1 (R243,EIPR.0,..,7 Page 0) is set on the input pin rising edge, if it is cleared, the pending bit is set on the falling edge of the input pin. Each source can be individually masked through the corresponding control bit IMA0,..,IMD1 (EIMR.7,..,0). See Figure 4-12.

The priority level of the external interrupt sources can be programmed among the eight priority levels with the control register EIPLR (R245). The priority level of each pair is software defined using the bits PRL2,PRL1. For each pair, the even channel (A0,B0,C0,D0) of the group has the even priority level and the odd channel (A1,B1,C1,D1) has the odd (lower) priority level. Figure 4-11 shows an example of priority levels.

Figure 4-11. Priority Level Examples

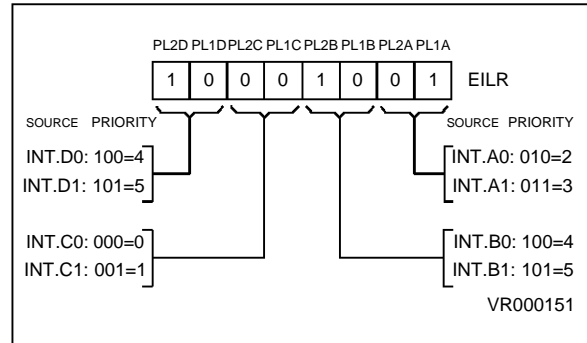

- The source of the interrupt channel A0 can be selected between the external pin INT0 (when IAOS = "1", the reset value) or the On-chip Timer/Watchdog peripheral (when IAOS = "0").
- The source of the interrupt channel B0 can be selected between the external pin INT2 (when (SPEN,BMS)=(0,0)) or the on-chip SPI peripheral.

All other interrupt channels have an input pin as source, however, the input line may be multiplexed with an on-chip peripheral I/O or connected to an input pin that performs also other function (as in the case of the handshake feature).

Table 4-3. Internal/External Interrupt Source

Channel	Internal Interrupt Source	External Interrupt Source
INTA0	Timer/Watchdog End of Count	INT0
INTB0	SPI Interrupt	INT2

EXTERNAL INTERRUPTS (Continued)

Figure 4-12. External Interrupts Control Bits and Vectors

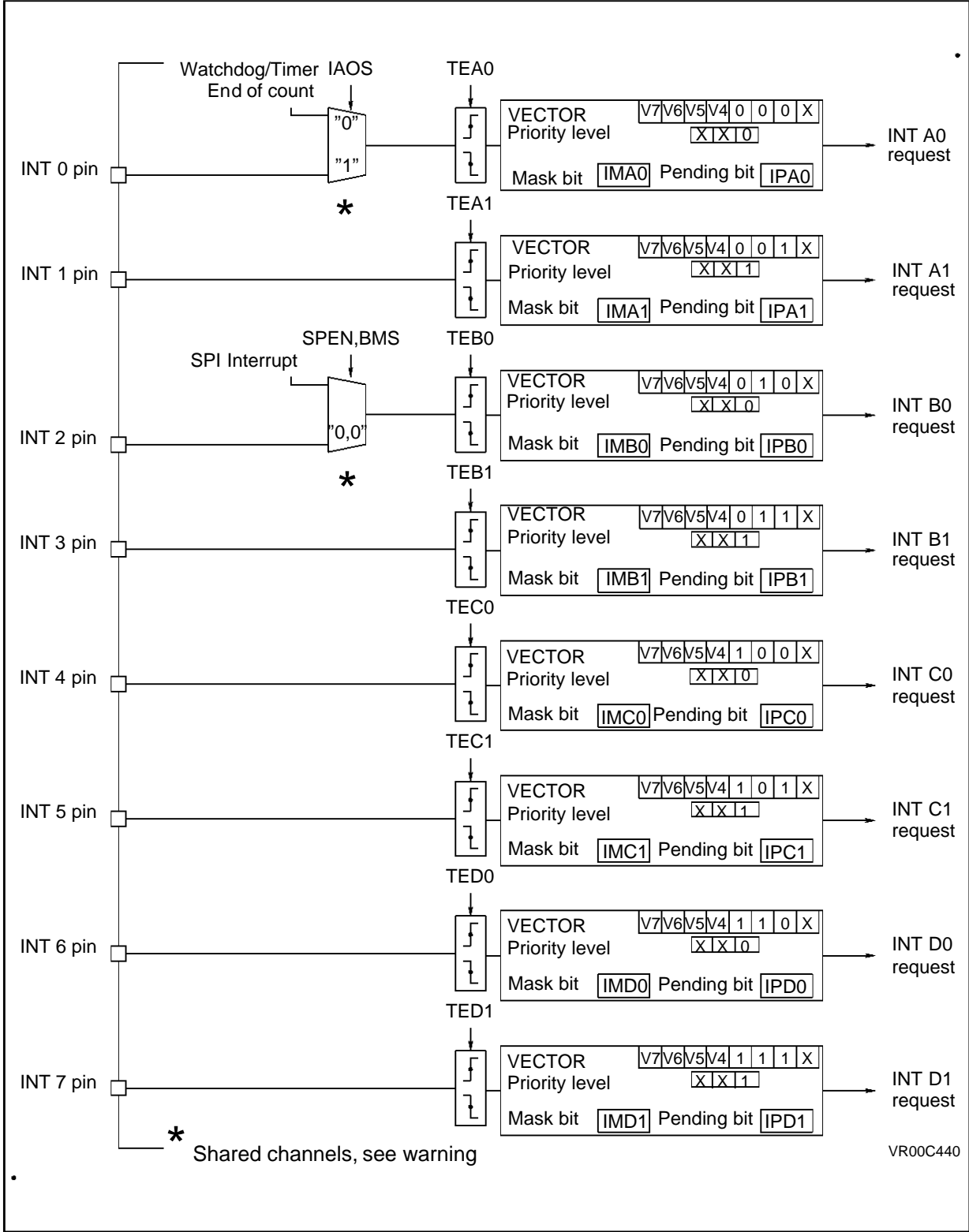

4.6 TOP LEVEL INTERRUPT

The Top Level Interrupt channel can be assigned either to the external pin NMI or to the Timer/Watchdog according to the status of the control bit EIVR.TLIS (R246.2, Page 0). If this bit is high (the reset condition) the source is the external pin NMI, if it is low, the source is the Timer/ Watchdog End Of Count. When the source is the NMI external pin, the control bit EIVR.TLTEV (R246.3; Page 0) selects between the rising (if set) or falling (if cleared) edge generating the interrupt request. When the selected event occurs, the CICR.TLIP bit (R230.6) is set. Depending on the mask situation, a Top Level Interrupt request may be generated. Two kinds of masks are available, a Maskable mask and a Non-Maskable mask. The first mask is the bit CICR.TLI (R230.5): it can be set or cleared to enable or disable respectively the Top Level Interrupt request. If it is enabled, the global Enable Interrupt bit CICR.IEN (R230.4) must also be enabled in order to allow a Top Level Request.

The second mask NICR.TLNM (R247.7) is a set-only mask. Once set, it enables the Top Level In-

terrupt request independently of the value of CICR.IEN and it cannot be cleared by program. Only the processor RESET cycle can clear this bit.

The Top Level Interrupt Service Routine cannot be interrupted by any other interrupt request, in any arbitration mode, even by another Top Level Interrupt request.

Warning. The interrupt machine cycle of the Top Level Interrupt does not clear the CICR.IEN bit, and the corresponding *iret* does not set it. Please refer to additional warning on page 40.

4.7 ON-CHIP PERIPHERAL INTERRUPTS

The general structure of the peripheral interrupt unit is described here, however each on-chip peripheral has its own specific interrupt unit containing one or more interrupt channels, or DMA channels. Please refer to the specific peripheral chapter for the description of its interrupt features and control registers.

Figure 4-13. Top Level Interrupt Structure

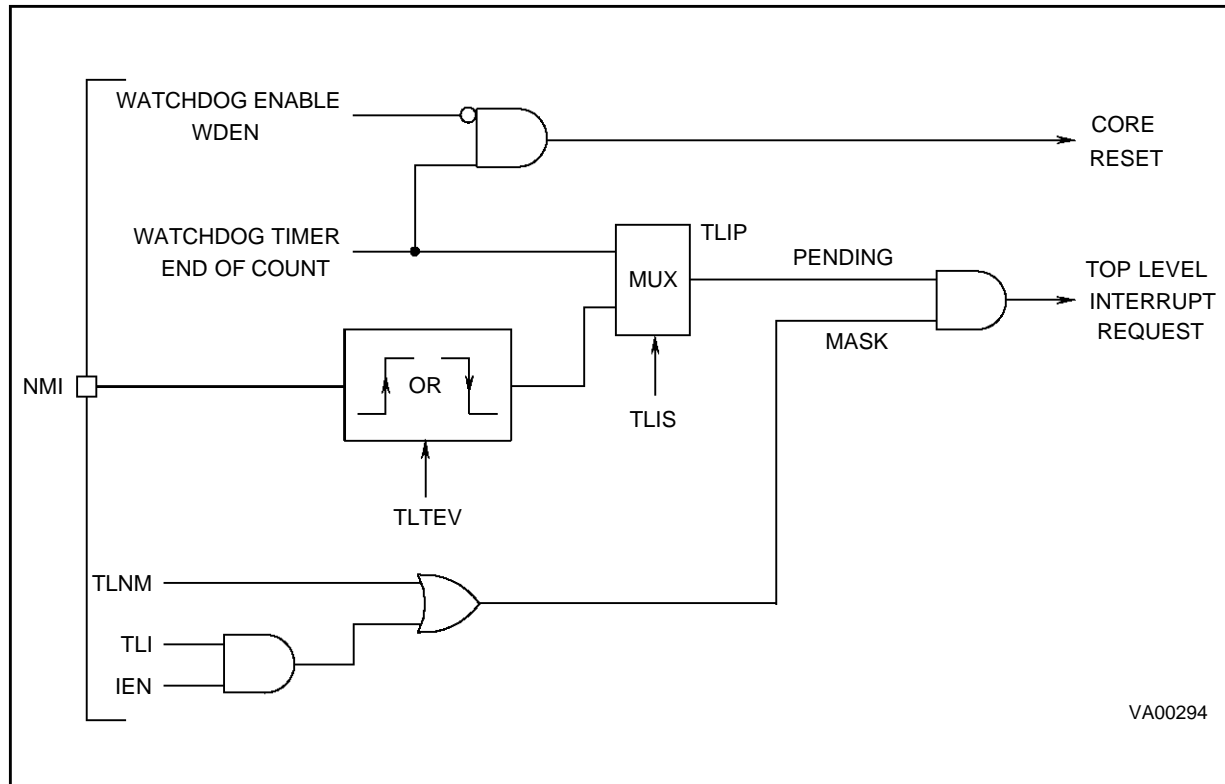

VA00294

ON-CHIP PERIPHERAL INTERRUPTS (Continued)

The on-chip peripheral interrupt channels provide the following control bits:

- Interrupt Pending bit (IP)
Set by hardware when the Trigger Event occurs. Can be set/cleared by software to generate/cancel pending interrupts and give the status for Interrupt polling.
- Interrupt Mask bit (IM)
If IM = "0", no interrupt request is generated. If IM = "1" an interrupt request is generated whenever IP = "1" and CICR.IEN = "1".

- Priority Level (PRL, 3 bits)
These bits define the source priority level
PRL=0: the highest priority
PRL=7: the lowest priority (the interrupt cannot be acknowledged)
- Interrupt Vector Register (IVR, up to 7 bits)
The IVR points to the vector table which itself contains the interrupt routine start address.

Figure 4-14. Wait For Interrupt Timing

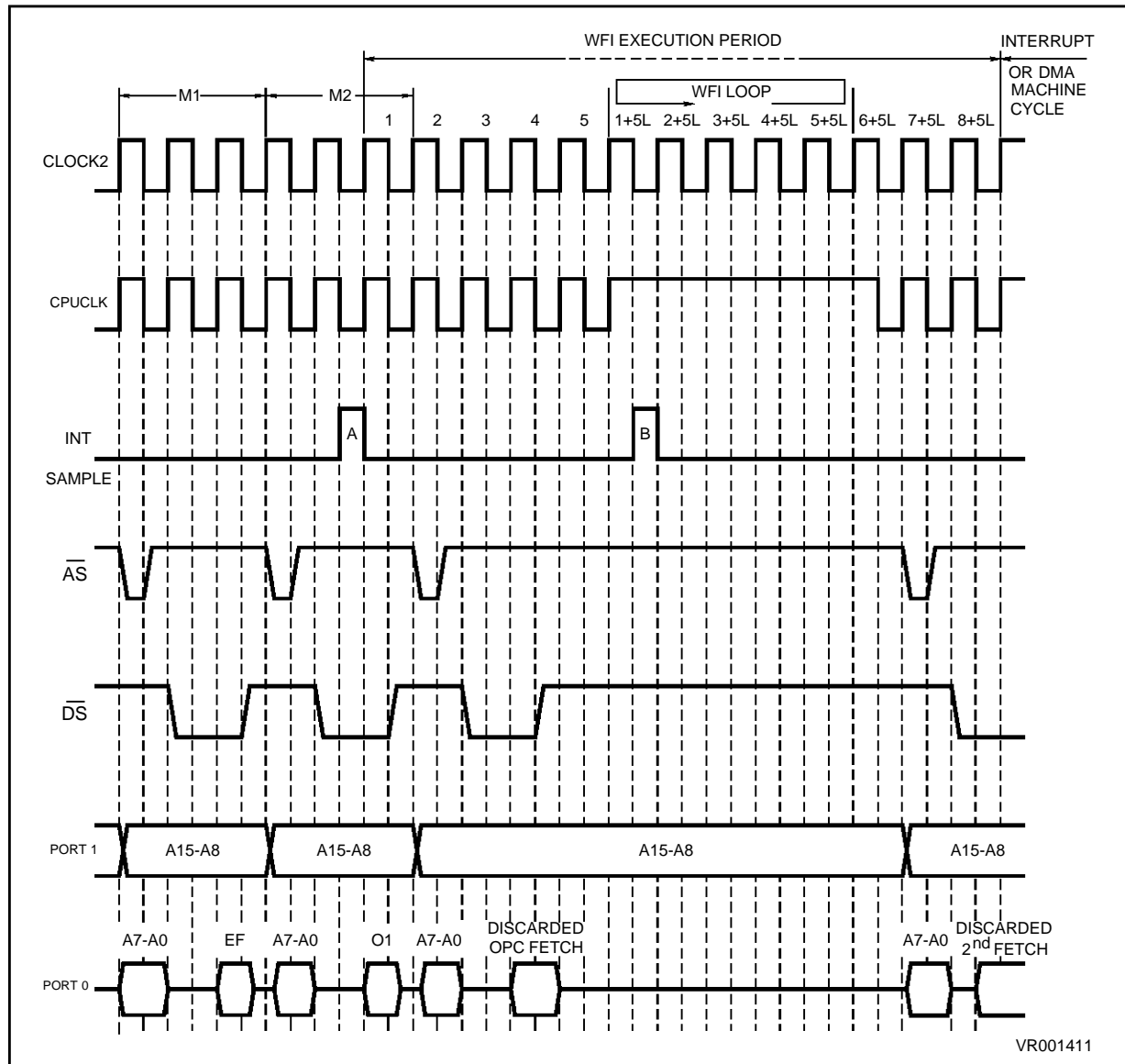

ST9 - Interrupts (ST902x)

4.8 WAIT FOR INTERRUPT INSTRUCTION

The Wait For Interrupt instruction suspends program execution until an interrupt request is acknowledged. During the WFI instruction, the CPUCLK is halted while INTCLK keeps running. Under this state, the power consumption of the processor is lowered by the CORE power consumption value.

4.9 INTERRUPT RESPONSE TIME

Interrupt requests are sampled 6 CPUCLK cycles before the end of the instruction. If Wait For Interrupt is in progress, requests are sampled every 5 CPUCLK cycles. If the interrupt request comes from an external pin, the programmed event has to be set a minimum of one CPUCLK cycle before the sampling time.

Figure 4-15. Interrupt Acknowledge Timing

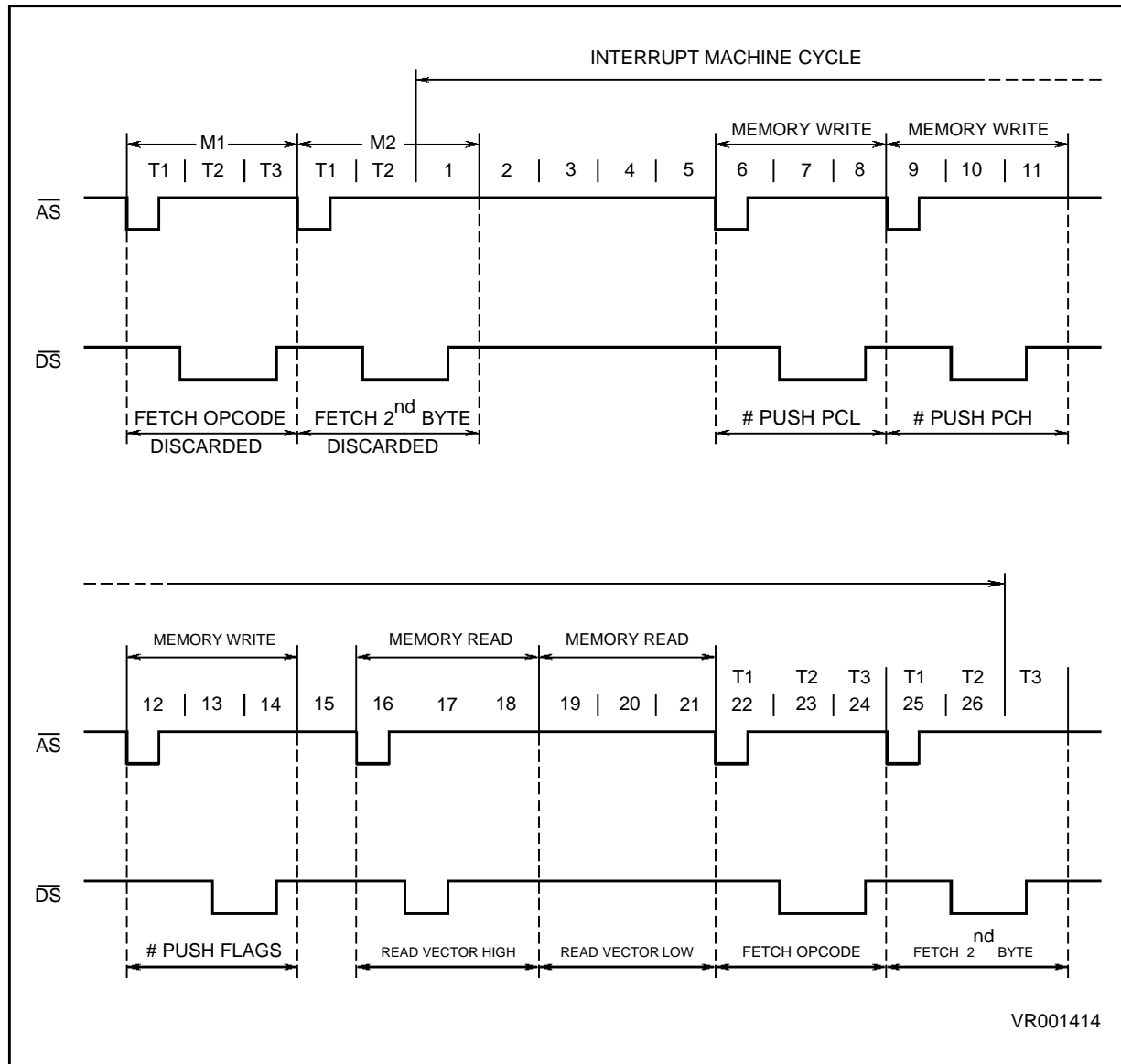

INTERRUPT RESPONSE TIME (Continued)

In order to guarantee the falling/rising edge detection, input signals must be kept low/high for a minimum of one CPUCLK cycle.

An interrupt machine cycle takes 26 internal clock cycles (CPUCLK), with some exceptions as follows:

- 28 internal clock cycles (CPUCLK), if a Wait For Interrupt is in progress
- 32 internal clock cycles (CPUCLK), if the acknowledge cycle follows a DMA transfer with Register File

Figure 4-16. External Interrupt Response Time

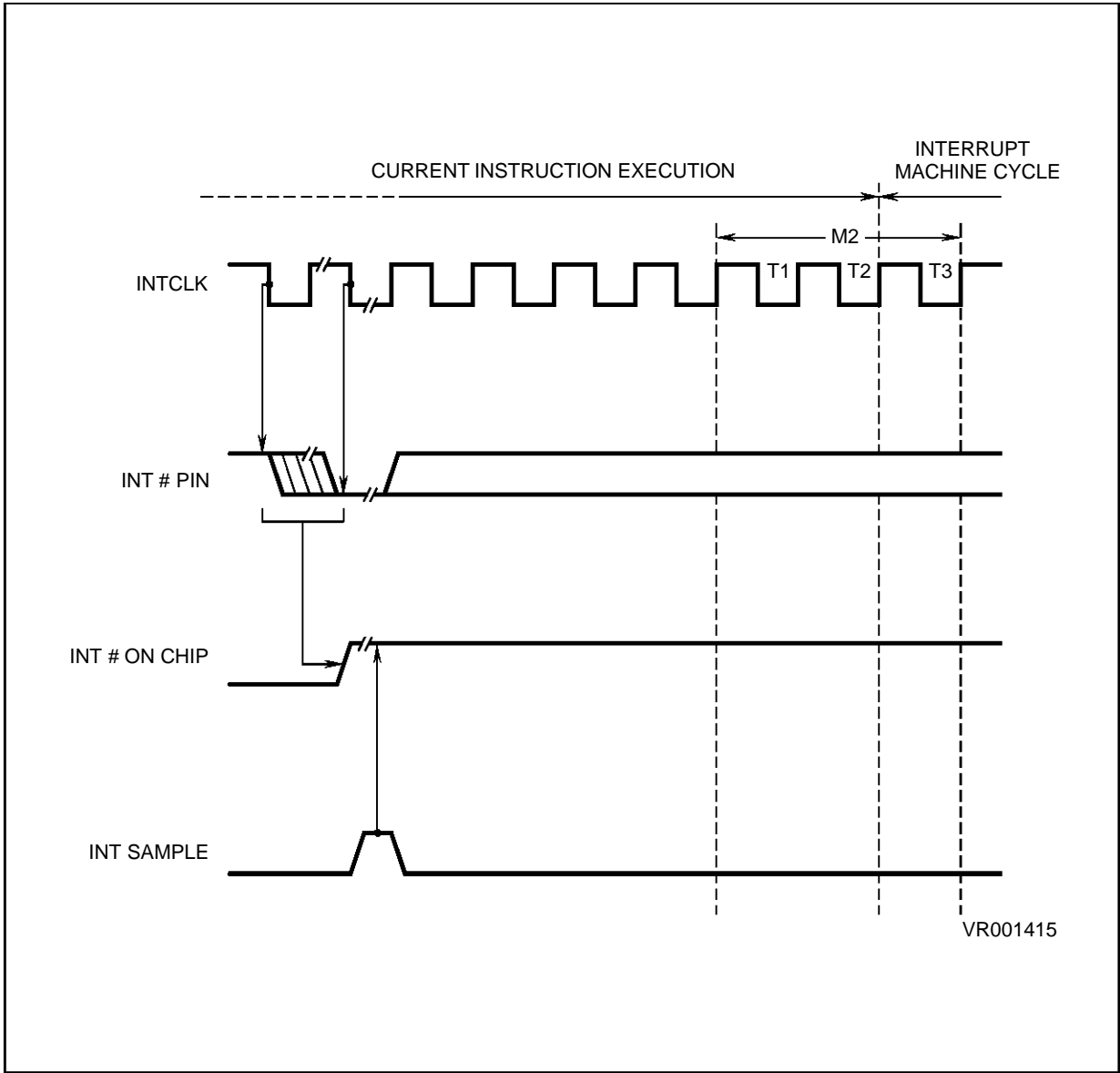

ST9 - Interrupts (ST902x)

4.10 INTERRUPT REGISTERS

CICR R230 (E6h) System Read/Write
Central Interrupt Control Register
Reset value: 1000 0111 (87h)

7	0						
GCEN	TLIP	TLI	IEN	IAM	CPL2	CPL1	CPL0

b7 = **GCEN**: *Global Counter Enable bit*. When set the 16 bit MultiFunction Timers are enabled (see Timer Control Register in MULTI FUNCTION TIMER chapter)

b6 = **TLIP**: *Top Level Interrupt Pending bit*. Set by hardware when the Trigger Event occurs. Cleared by hardware when the Top Level Interrupt is acknowledged.

b5 = **TLI**: *Top Level Interrupt bit*. If TLI = "1", and IEN is set, a Top Level Interrupt request is generated as TLIP is set. If TLI = "0", a request is generated only if TLNM is set.

b4 = **IEN**: *Interrupt Enable*. If IEN = "0", no maskable Interrupt requests are generated. This bit is cleared by the interrupt machine cycle and it is set by the IRET instruction of maskable routines.

b3 = **IAM**: *Interrupt Arbitration Mode*. If IAM = "0", Concurrent Arbitration Mode is selected; If IAM = "1" Nested Mode is selected.

b2-b0 = **CPL2, CPL1, CPL0**: *Current Priority Level*. Defines the Current Priority Level under service. CPL=0 is the highest priority. CPL=7 is the lowest priority. This bits may be modified directly by the interrupt hardware when the Nested Interrupt Mode is used.

EITR R242 (F2h) Page 0 Read/Write
External Interrupt Trigger Event Register
Reset value: 0000 0000 (00h)

7	0						
TED1	TED0	TEC1	TEC0	TEB1	TEB0	TEA1	TEA0

If TExy bit is set, the pending bit will be set upon the rising edge of the input signal.

If TExy is cleared, the pending bit will be set upon the falling edge of the input signal.

All bits are set/reset only by software.

b7 = **TED1**: *Trigger Event of Interrupt Channel D1*

b6 = **TED0**: *Trigger Event of Interrupt Channel D0*

b5 = **TEC1**: *Trigger Event of Interrupt Channel C1*

b4 = **TEC0**: *Trigger Event of Interrupt Channel C0*

b3 = **TEB1**: *Trigger Event of Interrupt Channel B1*

b2 = **TEB0**: *Trigger Event of Interrupt Channel B0*

b1 = **TEA1**: *Trigger Event of Interrupt Channel A1*

b0 = **TEA0**: *Trigger Event of Interrupt Channel A0*

EIPR R243 (F3h) Page 0 Read/Write
External Interrupt Pending Register

Reset value: 0000 0000 (00h)

7	0						
IPD1	IPD0	IPC1	IPC0	IPB1	IPB0	IPA1	IPA0

b7 = **IPD1**: *Interrupt Pending bit Channel D1*

b6 = **IPD0**: *Interrupt Pending bit Channel D0*

b5 = **IPC1**: *Interrupt Pending bit Channel C1*

b4 = **IPC0**: *Interrupt Pending bit Channel C0*

b3 = **IPB1**: *Interrupt Pending bit Channel B1*

b2 = **IPB0**: *Interrupt Pending bit Channel B0*

b1 = **IPA1**: *Interrupt Pending bit Channel A1*

b0 = **IPA0**: *Interrupt Pending bit Channel A0*

IP bits are hardware set upon the occurrence of the trigger event and are reset by the interrupt acknowledge machine cycle.

Note. IP bits may be set by the programmer to implement a software interrupt.

INTERRUPT REGISTERS (Continued)

EIMR R244 (F4h) Page 0 Read/Write
External Interrupt Mask-bit Register
Reset value: 0000 0000 (00h)

7							0
IMD1	IMD0	IMC1	IMC0	IMB1	IMB0	IMA1	IMA0

EIMR bits are set/reset by software
When the IM bit is set (and the global IEN is enabled), an interrupt request is generated if the corresponding IP bit is set. When IM = "0", no request will be generated.

- IMxy = "1": an interrupt request can be acknowledged (depending on IEN)
- IMxy = "0": an interrupt request is masked.

- b7 = **IMD1**: Interrupt Mask of Interrupt Channel D1
- b6 = **IMD0**: Interrupt Mask of Interrupt Channel D0
- b5 = **IMC1**: Interrupt Mask of Interrupt Channel C1
- b4 = **IMC0**: Interrupt Mask of Interrupt Channel C0
- b3 = **IMB1**: Interrupt Mask of Interrupt Channel B1
- b2 = **IMB0**: Interrupt Mask of Interrupt Channel B0
- b1 = **IMA1**: Interrupt Mask of Interrupt Channel A1
- b0 = **IMA0**: Interrupt Mask of Interrupt Channel A0

EIPLR R245 (F5h) Page 0 Read/Write
External Interrupt Priority Level Register
Reset value: 1111 1111 (FFh)

7							0
PL2D	PL1D	PL2C	PL1C	PL2B	PL1B	PL2A	PL1A

- EIPLR bits are set/reset by software
- b7-b6 = **PL1D, PL2D**: Priority level for the Group INTD0, INTD1
 - b5-b4 = **PL1C, PL2C**: Priority level for the Group INTC0, INTC1
 - b3-b2 = **PL1B, PL2B**: Priority level for the Group INTB0, INTB1
 - b1-b0 = **PL1A, PL2A**: Priority level for the Group INTA0, INTA1

EIVR R246 (F6h) Page 0 Read/Write
External Interrupt Vector Register
Reset value: xxxx 0110 (X6h)

7							0
V7	V6	V5	V4	TLTEV	TLIS	IAOS	EWEN

b7-b4 = **V7 to V4**: Most significant nibble of External Interrupt Vector. Not initialized by reset.

b3 = **TLTEV**: Top Level Trigger Event bit When set, the Top Level event is triggered on rising edge of NMI input pin. Triggering on the falling edge of the NMI input pin is activated when this bit is "0" (reset value)

b2 = **TLIS**: Top Level Input Selection bit This bit selects the source of the Top Level Interrupt between the external NMI pin (when "1", the reset value) and the Timer/Watchdog End of Count (when "0").

b1 = **IAOS**: Interrupt A0 Selection bit When set, the External Interrupt pin is selected as the External Interrupt Channel A0 source. When reset the source is the Timer/Watchdog End of Count interrupt.

b0 = **EWEN**: External Wait Enable bit When set, this bit enables the WAIT input pin to stretch the external memory access cycle. For more details of the WAIT mode, the reader should refer to the Clock and Wait chapter or External memory Interface chapter.

NICR R247 (F7h) Page 0 Read/Write
Nested Interrupt Control Register
Reset value: 0000 0000 (00h)

7							0
TLNM	HL6	HL5	HL4	HL3	HL2	HL1	HL0

- b7 = **TLNM**: Top Level Not Maskable.
If TLNM = "1", a top level request is generated as TLIP is set. Once TLNM is set, it can be cleared only with an hardware reset
- bx = **HLx**: Hold Level x These bits are set to "1" when, in Nested Mode, an interrupt service routine at level x is interrupted from a request with higher priority (other than the Top Level interrupt request). It is cleared by the `iret` execution when the routine at level x is recovered.

ST9 - Interrupts (ST902x)

WARNING

If a Maskable Top Level Interrupt is generated, and if the TLI pending bit is cleared by software, any further External Interrupt request is stopped until a new Top Level Interrupt is generated and serviced.

The conditions causing this are the following :

- 1) The Top Level Interrupt is maskable.
- 2) The arbitration cycle of the Top Level Interrupt happens during the first INTCLK cycle of the DI instruction.
- 3) The TLIP bit is cleared (Top Level Interrupt pending bit, R230, bit 6).
- 4) The IEN bit is set (Interrupt Enable bit, R230, bit 4).

A workaround to avoid this situation may be implemented in software, by exchanging the DI instruction in the program with any other instruction that clears IEN.

For example :

```
srp    # 28 ; System Register Group
bres r6.4 ; Reset bit 4 (equivalent
to DI)
```

5 ON-CHIP DMA

5.1 INTRODUCTION

The ST9 includes on chip Direct Memory Access (DMA) channels to provide high-speed data transactions between peripherals and memory or the Register File. Multi-channel DMA is fully supported by peripherals with their own controller and DMA channel(s). Each DMA channel transfers data to or from contiguous locations of the Register File, Program Memory or Data Memory. The maximum number of transactions that each DMA channel can perform is 222 if the Register File is selected, or 65536 if Program or Data Memory is selected.

The DMA controller in the Peripheral uses an indirect addressing mechanism to DMA Pointers and Counter Registers stored in the Register File. This is the reason that the maximum number of transactions for Register File is 222, as two Registers are allocated for the Pointer and Counter. Register pairs are used for memory pointers and counters to offer the full 65536 byte and count capability.

The ST9 supports a fully programmable DMA priority structure included within the interrupt structure.

5.2 DMA PRIORITY LEVEL ARCHITECTURE

The 8 priority levels used for interrupts are also used to prioritize the DMA requests, which are arbitrated in the same arbitration phase as interrupt requests. If the event occurrence requires a DMA transaction, this will take place at the end of the current instruction execution. When an interrupt and a DMA request occur simultaneously, on the same priority level, the DMA request is serviced before the interrupt.

Note however that an interrupt priority request must be *higher* than the CPL value in order to be acknowledged. For a DMA transaction request, it must be *equal to or higher than* the CPL value in order to be executed.

Thus only DMA transaction requests can be acknowledged when CPL = 7.

DMA requests do not modify the CPL value as the DMA transaction is non-interruptable.

Figure 5-1. DMA Overview

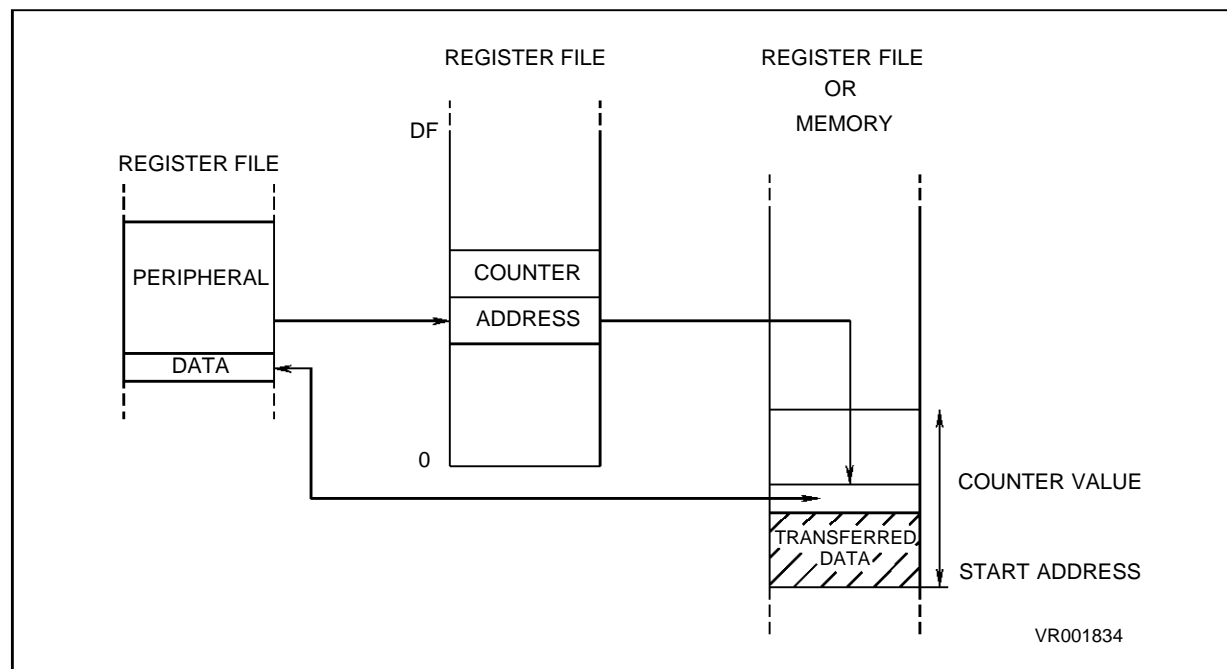

DMA TRANSACTIONS (Continued)

Figure 5-2. DMA Between Registers and peripherals

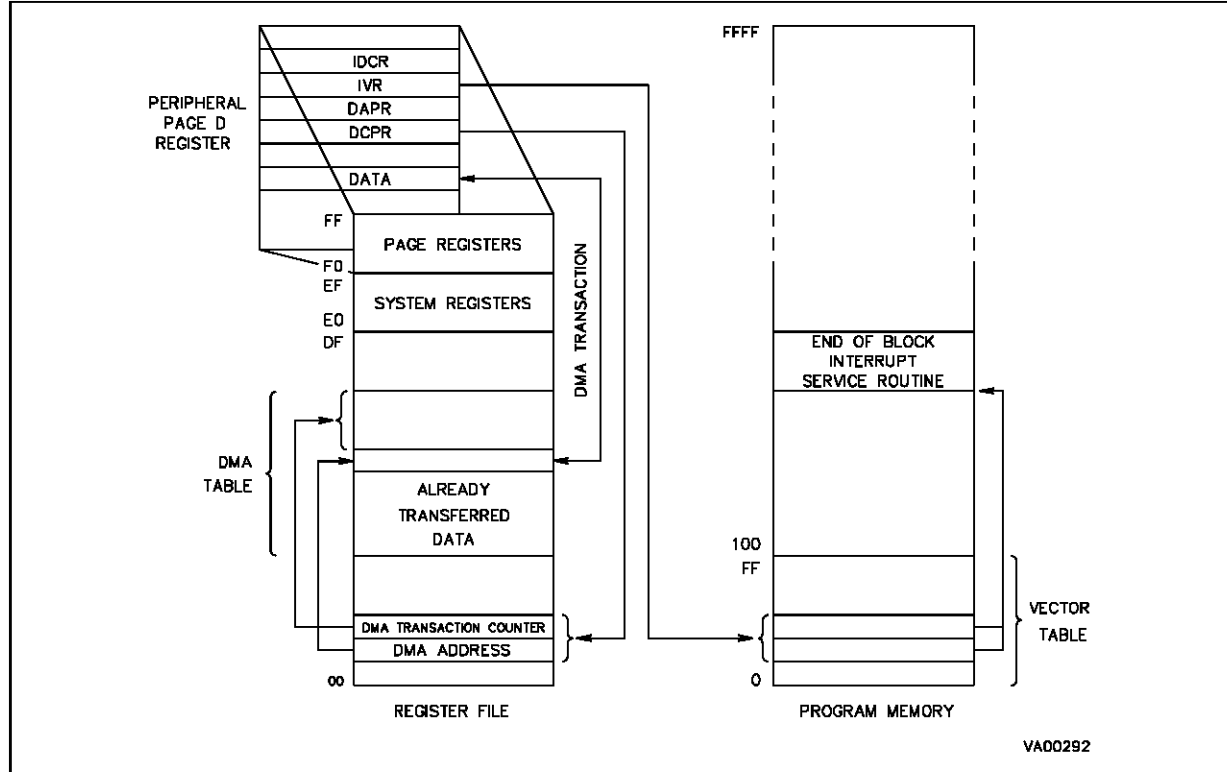
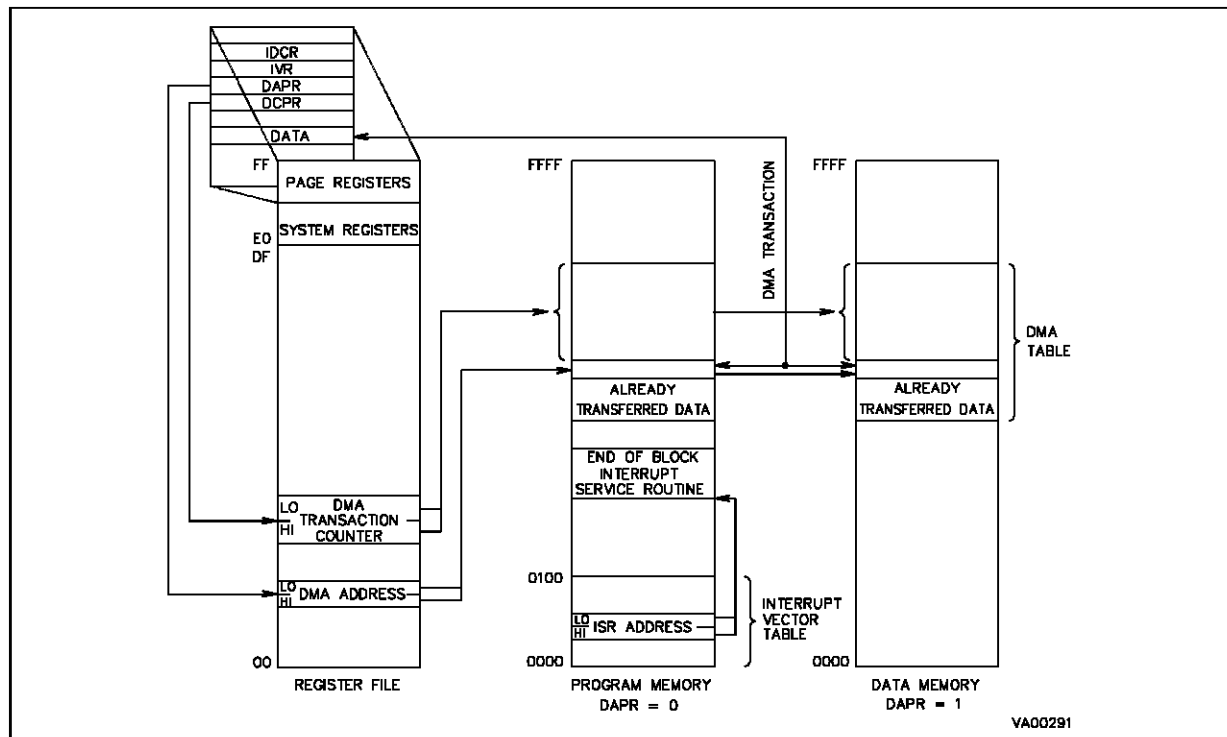

Figure 5-3. DMA Between Memory and peripherals



5.3 DMA TRANSACTIONS

The purpose of on-chip DMA channel is to transfer a block of data from/to the peripheral to/from Register File or Memory. Each DMA transfer consists of three operations:

- A load from/to the peripheral data register to a location of Register File (or Memory) addressed through the DMA Address Register (or Register pair)
- A post-increment of the DMA Address Register (or Register pair)
- A post-decrement of the DMA transaction counter, which contains the number of transactions that have still to be performed.

If the DMA transaction is made between **the peripheral and the Register File** (Figure 5-2), one register is required to hold the DMA Address and one to hold the DMA transaction counter. These two registers must be located in the Register File: the DMA Address Register in the even addressed register, the DMA transaction Counter in the following register (odd address). They are pointed to by the DMA Transaction Counter Pointer Register (DCPR) located in the page registers of the peripheral. In order to select the DMA transaction with the Register File, the control bit DCPR.RM (bit 0 of DCPR) must be set.

The Transaction Counter Register must be initialized with the number of DMA transfers to perform and will be decremented after each transaction. The DMA Address Register must be initialized with the starting address of the DMA table in the Register File, and is increased after each transaction. These two registers must be located between addresses 00h and DFh of the Register File.

If the transaction is made between **the peripheral and Memory Space (Program or Data Memory)**, a register pair (16 bits) is required for the DMA Address and for the DMA transaction Counter (Figure 5-3). Thus, two register pairs must be located in the Register File. The DMA Transaction Counter is pointed to by the DMA Transaction Counter Pointer Register (DCPR), the DMA Address is pointed to by the DMA Address Pointer Register (DAPR), both DCPR and DAPR are located in the page registers of the peripheral. When selecting the DMA transaction with memory, the control bit DCPR.RM (bit 0 of DCPR) must be cleared to "0".

To select between Program or Data Memory, the control bit DAPR.DP (bit 0 of DAPR) must be cleared or set respectively.

Once the DMA table is completed (the transaction counter reaches 0 value), an Interrupt request to the CPU is generated.

The DMA transaction Counter must be initialized with the number of transactions to perform and will be decremented after each transaction. The DMA Address must be initialized with the starting address of the DMA table and is increased after each transaction. These two register pairs must be located between addresses 00h and DFh of the Register File.

Once a DMA channel is initialized, a transfer can start. The direction of the transfer (data from/to peripheral to/from memory or Register File) is automatically defined by the type of peripheral and programming mode.

When the Request Pending bit is set by a hardware event (or by software), and the DMA Mask bit is set, a DMA request is generated. If the Priority Level of the DMA source is higher than or equal to the Priority Level under service (CPL) the DMA transfer is executed at the end of the current instruction. DMA transfer reads/writes data from/to the location pointed by the DMA Address Register, increments the DMA Address register and decrements the Transaction Counter Register. When the content of the Transaction Counter is decremented to zero, the DMA Mask bit (DM) is cleared and an interrupt request is generated according to the Interrupt Mask bit (End of Block interrupt). This End-of-Block interrupt request is taken into account depending on the PRL value.

WARNING. *DMA requests are not acknowledged if the top level interrupt service is in progress.*

5.4 DMA CYCLE TIME

DMA and Interrupt requests are sampled 6 INTCLK cycles before the end of the instruction. If Wait For Interrupt is in progress, requests are sampled every 5 INTCLK cycles. DMA transactions are executed if their priority allows it.

A DMA transfer with the Register file takes 8 CPUCLK cycles, except when the Wait For Interrupt is in progress (10 CPUCLK cycles).

A DMA transfer with the memory takes 16 CPUCLK cycles except when the Wait For Interrupt is in progress (18 CPUCLK cycles).

Figure 5-4. DMA Transaction to Memory

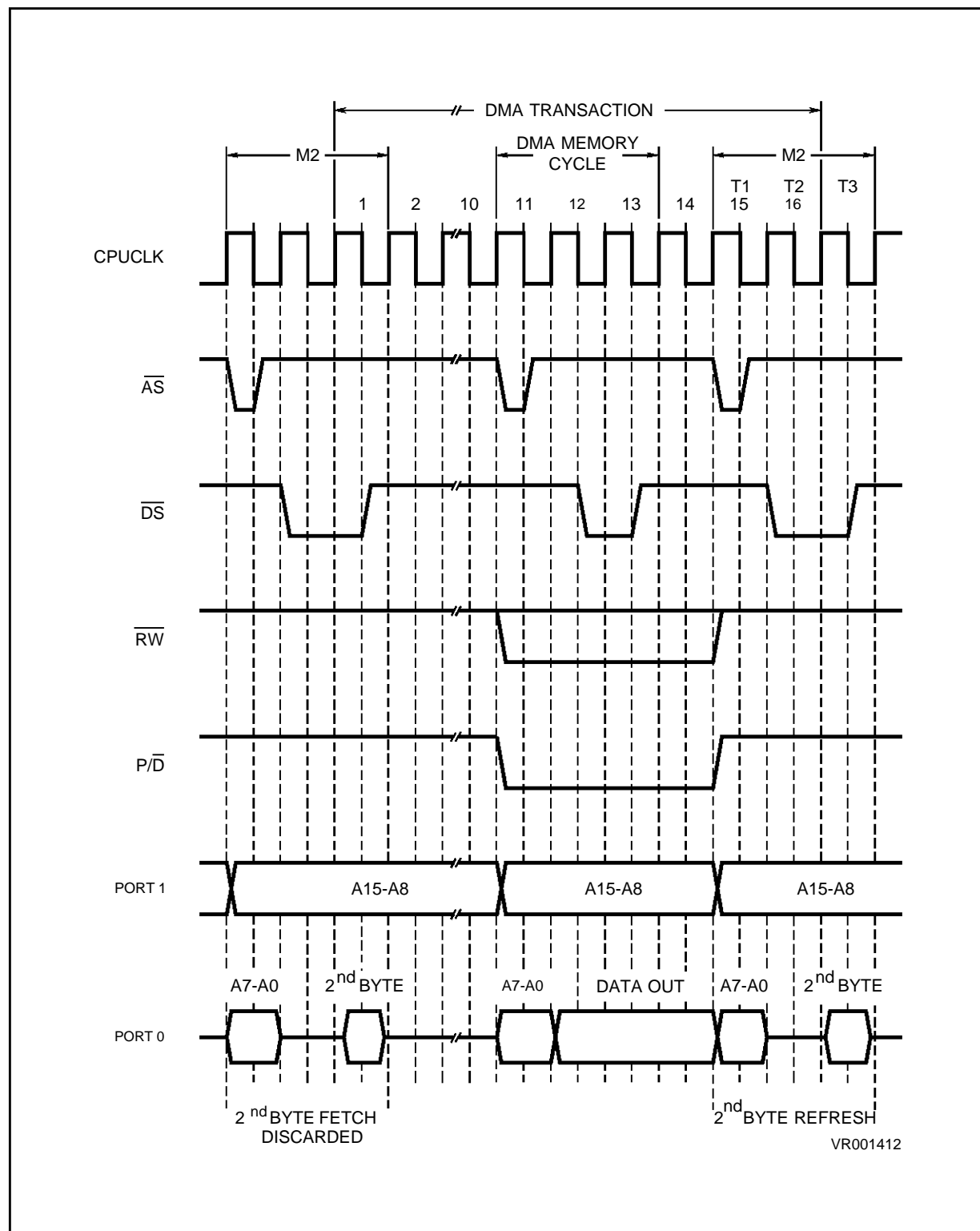
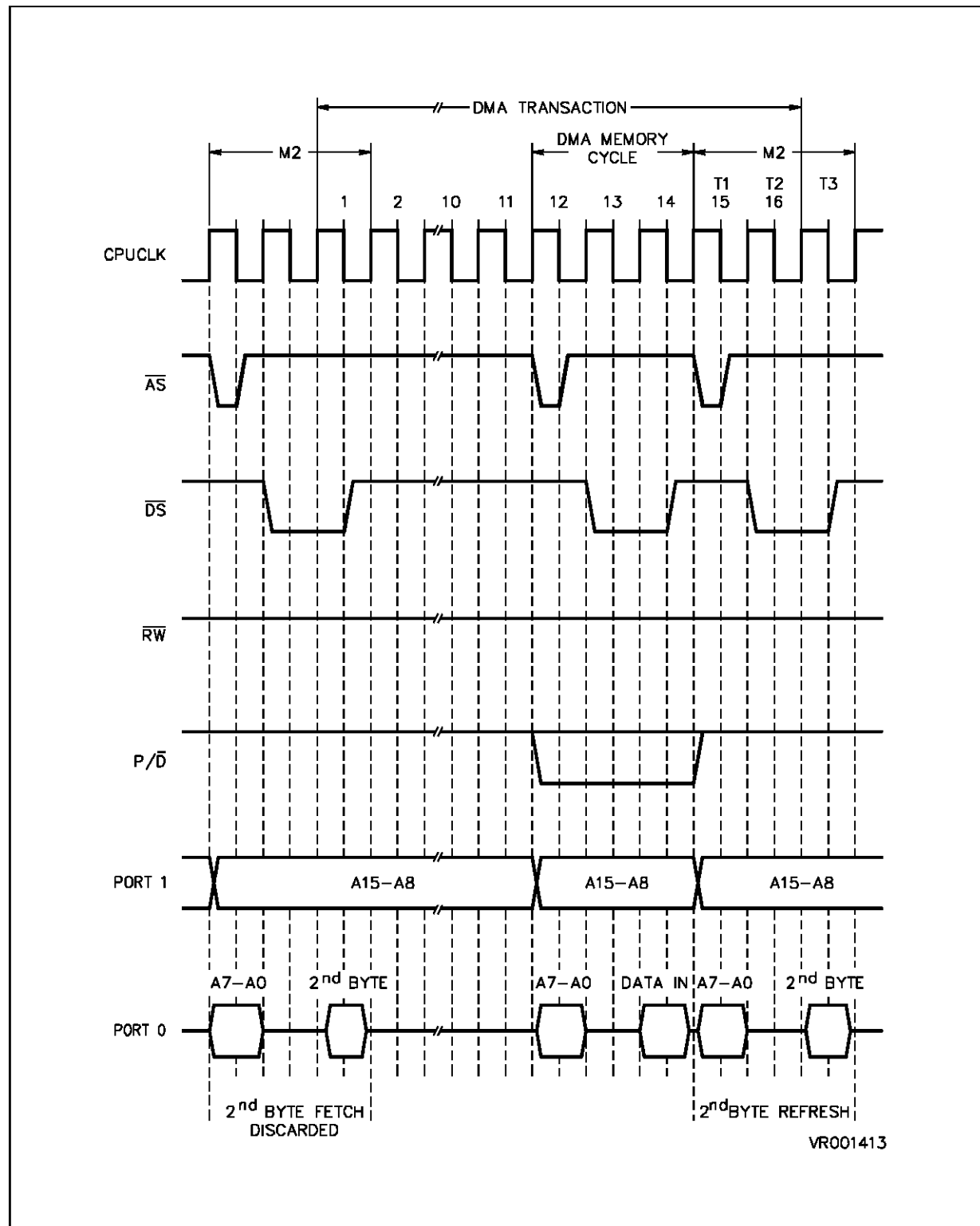

Figure 5-5. DMA Transaction from Memory



ST9 - DMA (ST902x)

5.5 THE SWAP-MODE

An extra feature of ST9 DMA channels of some peripherals (i.e the MultiFunction TIMER) is the SWAP mode. This feature allows transaction from two DMA tables alternatively. All the DMA descriptors in the Register File are thus doubled. Two DMA transaction counters and two DMA address pointers allow the definition of two fully independent tables (they only have to belong the same space, Register file or Data memory or Program memory). The DMA transaction is programmed to start on one of the two tables (say table 0) and, at the end of block, the DMA controller automatically swaps to the other table (table 1) by pointing to the other DMA descriptors. In this case, the DMA mask (DM bit) control bit is not cleared, but the End Of Block interrupt request is generated to allow the optional updating of the first data table (table 0).

Until the swap mode is not disabled, the DMA controller will continue to swap between DMA Table 0 and DMA Table 1.

5.6 DMA REGISTERS

As each peripheral DMA channel has its own control registers, the following register list should be considered as a general example. The names and register bit allocation shown here may be different from those found in the peripheral chapters.

DCPR Address set by Peripheral Read/Write DMA Counter Pointer Register

Reset value: undefined

7							0
C7	C6	C5	C4	C3	C2	C1	RM

b7-b1 = **C7-C1**: DMA Transfer Counter Register(s) Address

b0 = **RM**: Register File/Memory Selector If set, the DMA transactions are done with the Register File; if cleared, the DMA transactions are done with the Program or Data memory (see DAPR.DP)

IDCR Address set by Peripheral Read/Write Generic Peripheral Interrupt and DMA Control

Reset value: undefined

7						0	
		IP	DM	IM	PRL2	PRL1	PRL0

b5 = **IP**: *Interrupt Pending*. Set by hardware when the Trigger Event occurs. Cleared by hardware when the request is acknowledged for DMA cycles and external interrupts only. Can be set/cleared by software in order to generate/cancel a pending request. Identical in function to IP of ICR.

b4 = **DM**: *DMA Mask*. If DM = "0" no DMA request is generated when the trigger event occurs. This bit is cleared whenever the transaction counter reaches zero (unless SWAP mode is active).

b3 = **IM**: *Interrupt Mask*. If IM = "0" no interrupt request is generated. If IM = "1" DMA requests depend on DM bit value as shown above.

b2-b0 = **PRL2, PRL1, PRL0**: *Priority Level* Definition of the source priority level. PRL = 0 is highest priority. If PRL = 7, no interrupt can be acknowledged, DMA requests will be.

DAPR Address set by Peripheral Read/Write DMA Address Pointer Register

Reset value: undefined

7							0
A7	A6	A5	A4	A3	A2	A1	DP

b7-b1 = **A7-A1**: DMA Address Register(s) Address

b0 = **DP**: *Data/Program Memory Selector*: (DAPR.RM is "0") if set the DMA transactions are made with the Data Memory; if cleared the DMA transactions are made with the Program Memory.

6 CLOCK

6.1 INTRODUCTION

The ST9 Clock generator module generates the internal clock for the ST9 core and the on-chip peripherals. The Clock generator can be driven by an external crystal circuit, connected to the OSCIN and OSCOUT pins, or by an external pulse generator, connected to OSCIN.

6.2 CLOCK MANAGEMENT

The oscillator circuit generates an internal clock signal with the same period and phase as at the OSCIN input pin. The maximum frequency allowed is 24MHz.

As shown in Figure 6-1, the CLOCK1 signal drives a programmable divider by two. If the control bit MODER.DIV2 (R235.5) is set, the internal clock CLOCK2 is CLOCK1 divided by two; otherwise, if DIV2 bit is cleared, the clock signal CLOCK2 has the same period and phase as CLOCK1. CLOCK2 drives the internal clock INTCLK delivered to all ST9 on-chip peripherals and acts as the central timebase for all timing functions (e.g. Multifunction Timer or Serial Communications Interface Baud Rate generator).

The maximum frequency allowed for INTCLK is 12MHz. For internal operating frequencies above 8MHz, it is recommended to work with the Clock Divider active in order to provide a duty cycle of 50% for INTCLK.

CLOCK2 also drives a programmable prescaler which generates the basic time base, CPUCLK, for the instruction executor of the ST9 core. This allows the user to slow the program execution time to reduce power dissipation, and to locally speed up certain code segments for time critical routines. The internal peripherals are not affected by the CPUCLK prescaler. The prescaler value divides the input clock by the value programmed in the control bits MODER.PRS2,1,0 (R235.4,3,2). If the prescaler value is zero, no prescale is made, thus CPUCLK has the same period and phase as CLOCK2 and INTCLK. If the value is different from 0, the prescaling is equal to the value plus one, ranging thus from two (PRS2,1,0 = 1) to eight (PRS2,1,0 = 7). The clock generated is shown in Figure 6-2. It must be noticed that the prescaling of the clock does not keep the duty cycle to 50%, but stretches the high level of the clock until completion.

When External Memory Wait (or Bus Request or Wait for Interrupt) events occur, CPUCLK is stretched on the high level for the whole period required by the function.

Note. The added wait cycles refer to the INTCLK frequency and not the original CPUCLK.

Figure 6-3 shows an example of a memory access cycle with the CPUCLK prescaled by 2 and with 5 added Wait states.

Figure 6-1. Peripheral and Core Clocks

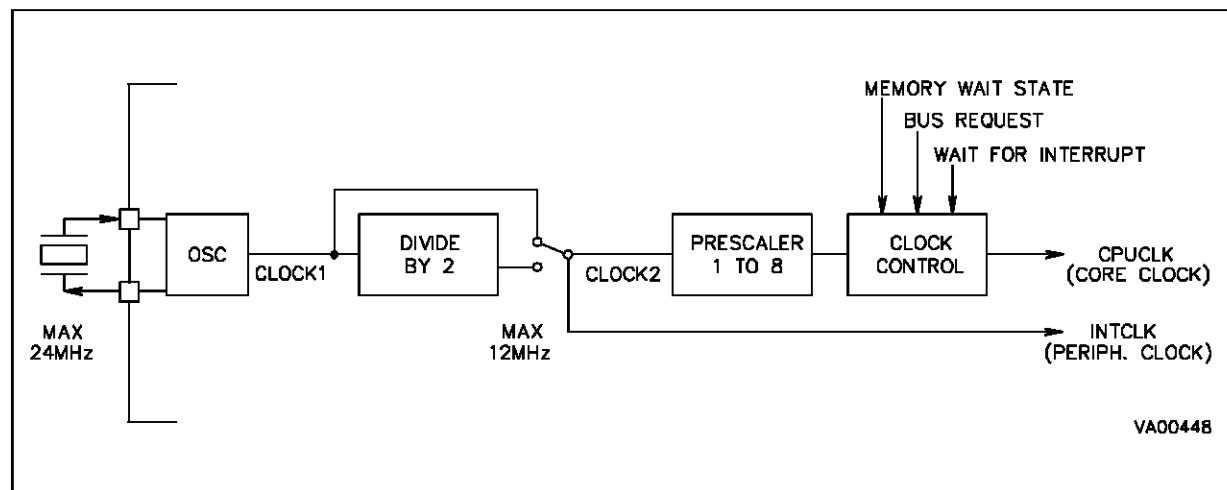

ST9 - Clock (ST902x)

6.3 CLOCK CONTROL REGISTER

The ST9 clock division by 2 and the clock prescaling are controlled by the MODER register.

Note. This register contains bits with other functions. Only the bits relating to control of the clock are shown here.

MODER R235 (EBh) System Read/Write Mode Register

Reset Value : 1110 0000 (E0h)

7						0	
X	X	DIV2	PRS2	PRS1	PRS0	X	X

b5 = **DIV2**: *OSCIN Divided by 2*. This bit controls the divide by 2 circuit which operates on the OSCIN Clock. A logical "1" value means that the OSCIN clock is internally divided by 2, and a logical "0" value means that no division of the OSCIN Clock occurs.

b4-b2 = **PRS2, PRS1, PRS0**: *Prescaling of ST9 Clock*. These bits define the prescaler value used to prescale the CPUCLK from INTCLK. When these three bits are reset, the CPUCLK is not prescaled, and is equal to INTCLK; in all other cases, the internal clock is prescaled by the value of (PRS2,1,0 + 1).

Figure 6-2. Core Clock Prescaling

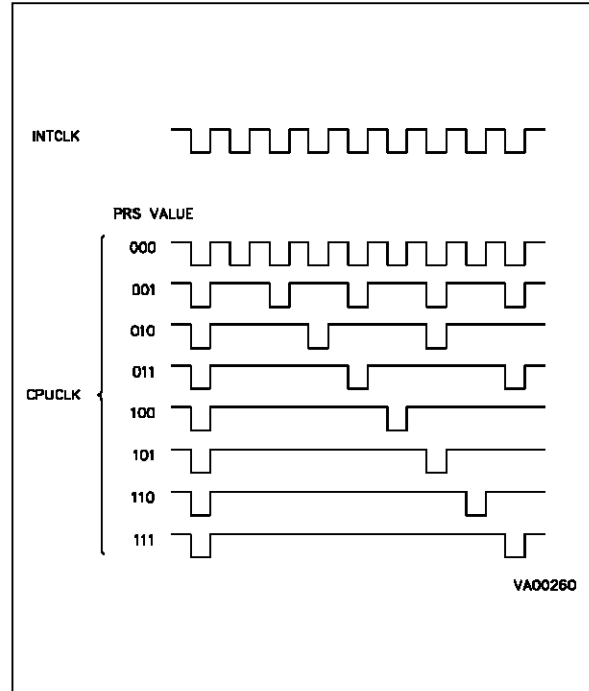
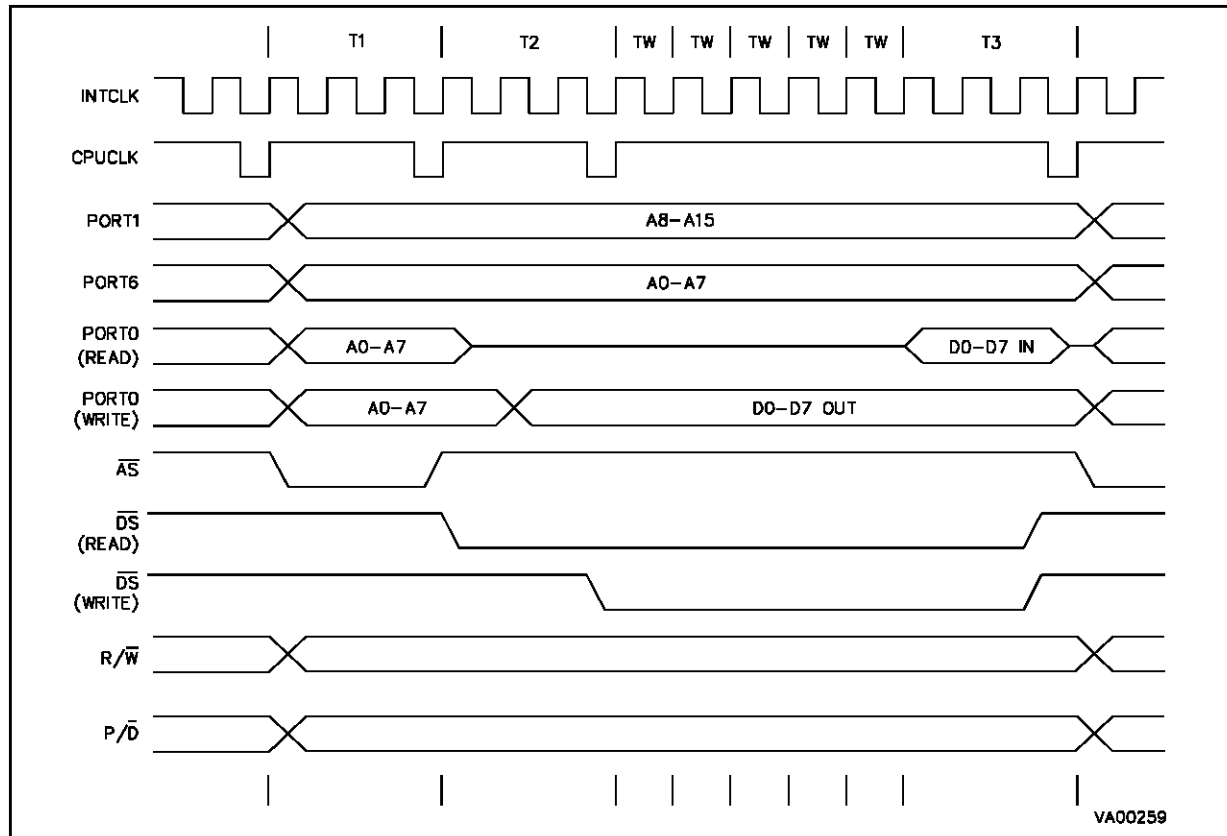

Figure 6-3. Memory Access with a Clock Prescaler by 2 and 5 Wait Cycle



6.4 OSCILLATOR CHARACTERISTICS

The on-chip oscillator circuit (Figure 6-4) is an inverting gate circuit.

Note. Owing to the Q factor required, Ceramic Resonators may not provide a reliable oscillator source.

In Halt mode, set by means of the `HALT` instruction, the parallel resistor R is disconnected and the oscillator is disabled, forcing the internal clock `CLOCK1` to a high level and `OSCOUT` to a high level.

To exit the `HALT` condition and restart the oscillator, an external `RESET` pulse is required of a minimum duration of 12ms (Figure 6-7).

It must be noted that if the Timer/Watchdog watchdog function is enabled, a `HALT` instruction will not disable the oscillator. This to avoid stopping the watchdog if, by an error, a `HALT` code is executed. When this occurs, the ST9 CPU falls into an endless loop ended by the watchdog (or external) reset.

Figure 6-4. Internal Oscillator Schematic

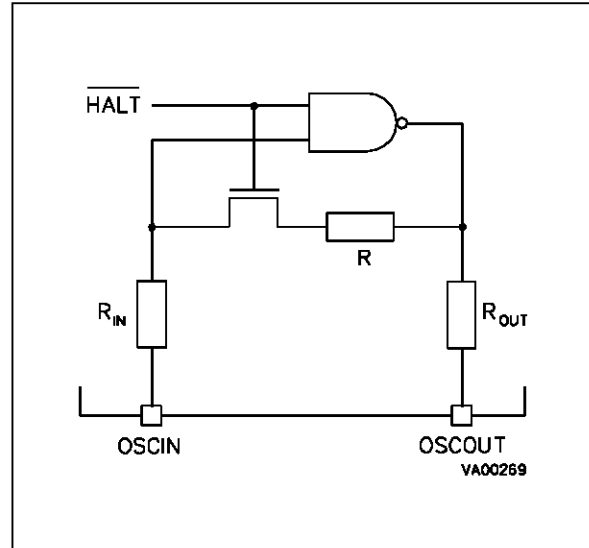

Note: $R_{OUT} < 50\Omega$ $R > 1M\Omega$ $300\Omega < R_{IN} < 500\Omega$

Figure 6-5. Crystal Oscillator

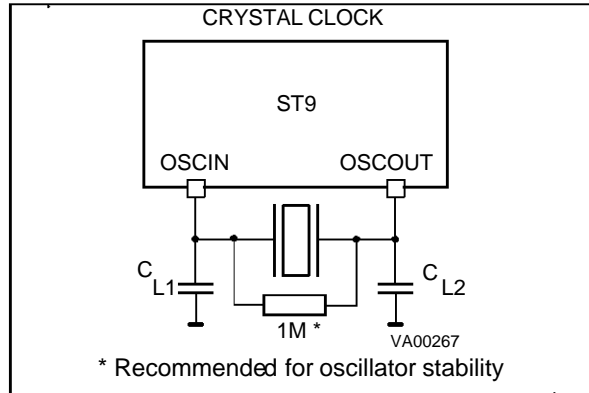

Table 6-1. Crystal Specification (C0 <= 7pF)

Frequency (MHz)	C1=C2=56pF Rs Max	C1=C2=47pF Rs Max	C1=C2=22pF Rs Max
24	20	25	70
16	40	60	150
12	80	100	250
8	180	240	600
4	700	800	600

Figure 6-6. External Clock

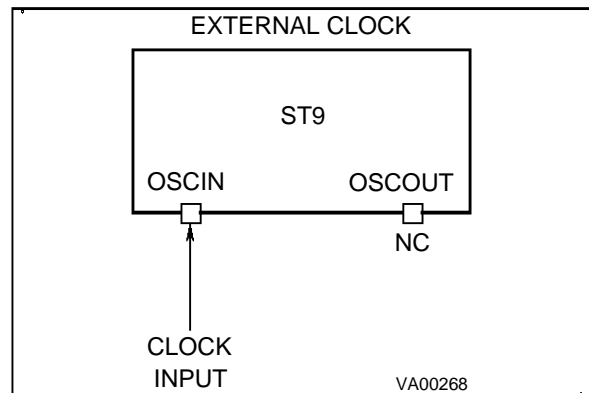

Table 6-2. Oscillator Transductance

gm	Min	Typ	Max
mA/V	3	5.8	9.5

Legend:

Rs: Parasitic Series Resistance of the quartz crystal (upper limit)
 C0: Parasitic capacitance of the quartz crystal (upper limit, < 7pF)
 C1, C2: Maximum Total Capacitances on pins OSCIN and OSCOUT (the value includes the external capacitance tied to the pin plus the parasitic capacitance of the board and of the device)
 gm: Transconductance of the oscillator

Note. The tables are relative to the fundamental quartz crystal only (not ceramic resonator).

OSCILLATOR CHARACTERISTICS (Continued)

Figure 6-7. Oscillator Start-up Sequence

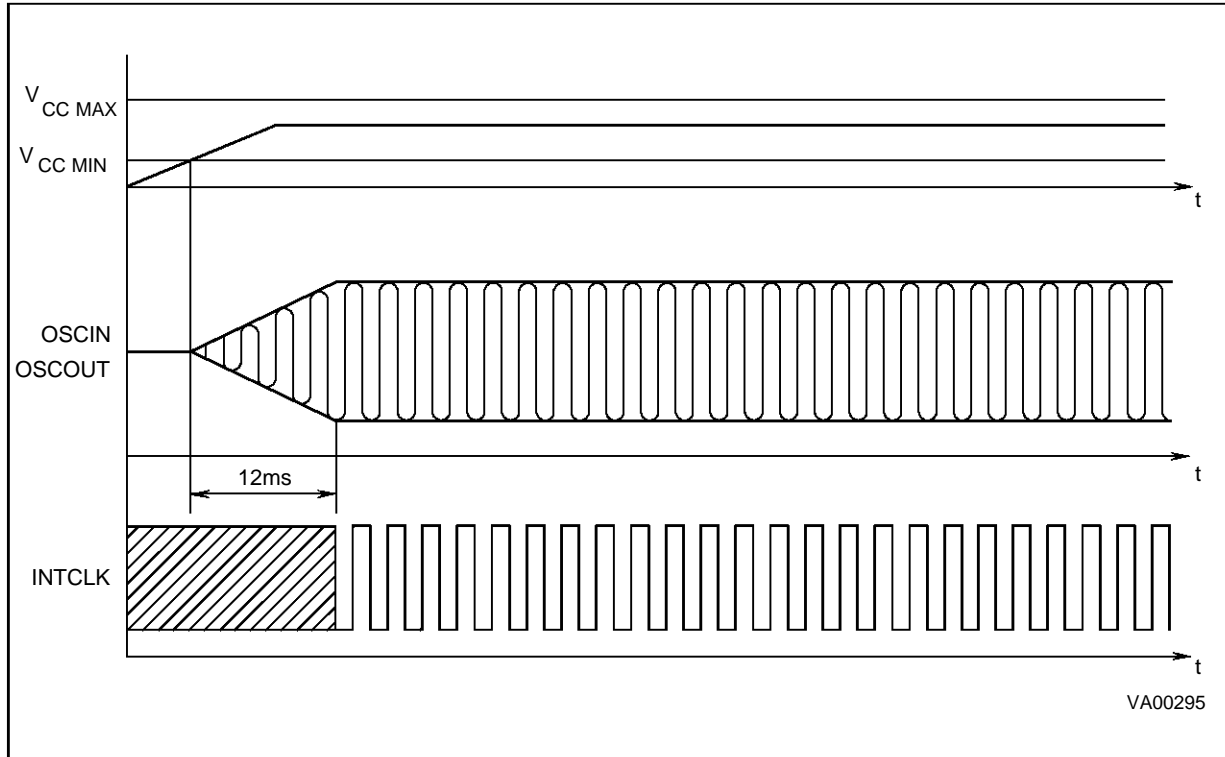

7 RESET

7.1 INTRODUCTION

The processor Reset overrides all the other conditions and forces the ST9 to the reset state. During Reset, the internal registers are set to the reset value, as shown in Table 7-1 for the system and Page 0 Registers and the I/O pins are set to the Bidirectional Weak Pull-up mode (see Warning). The programmer must then initialize the ST9 system and peripheral control registers to give the required functions.

7.2 RESET GENERATION

The reset condition can be generated by the external pin $\overline{\text{RESET}}$ or by the on-chip Timer/Watchdog.

The on-chip Timer/Watchdog generates a reset condition if the watchdog mode is enabled (WCR.WDEN cleared, R252 page 0), and if the programmed period elapses without the specific code (AAh,55h) written to the appropriate register. The input pin RESET is not driven low by the on-chip reset generated by the Timer/Watchdog.

During reset, the $\overline{\text{DS}}$ output signal is kept low and the $\overline{\text{AS}}$ output is toggled with the crystal frequency (input at OSCIN) divided by 32. This condition is recognized by off-chip Z-bus peripherals as a reset condition.

7.3 RESET PIN TIMING

The $\overline{\text{RESET}}$ pin has a Schmitt trigger input circuit with hysteresis. The internal reset is generated by the external pin synchronized with the internal clock. The power up reset circuit must keep the $\overline{\text{RESET}}$ input low for a minimum of the crystal startup period plus 53 crystal periods.

Once the $\overline{\text{RESET}}$ pin reaches a logical "1", the processor exits from the reset status after 67 crystal periods from the rising edge ($\overline{\text{DS}}$ is set). The processor then fetches from Program Memory locations 0 and 1 (power-on reset vector) and begins program execution from the address contained in the vector. If the ST9 is a ROMLESS version, without on-chip program memory, ports Port0, Port1 (and Port6 for ST905x family) are set to external memory mode (i.e Alternate Function) and the memory accesses are made to external Program memory with wait cycles insertion.

WARNING: I/O pins are set to the Weak Pull-up mode during the Reset cycle. This state is forced during the reset sequence, but the I/O pins can be in a random state for up to 64 crystal periods.

The application circuit must take this into account if it can lead to critical situations in the external circuitry.

Figure 7-8. Signal to be applied on Reset Pin

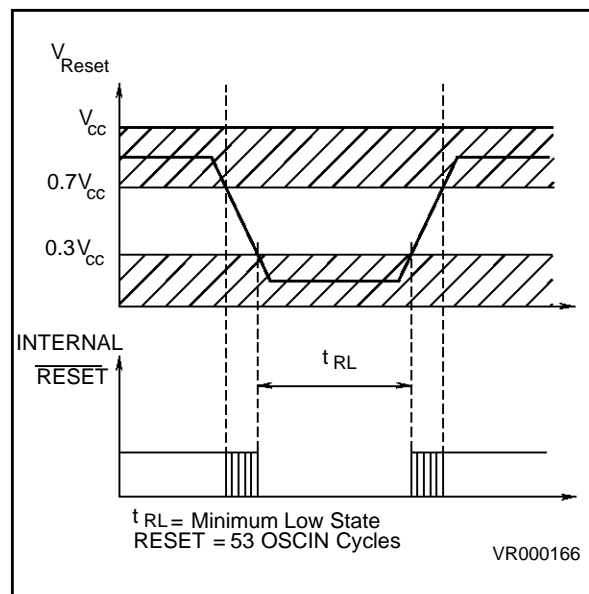

7.4 PROCESSOR SYNCHRONIZATION UNDER RESET

During reset, a specific procedure has been implemented to synchronize two or more oscillators in a multi-micro ST9 based system, for example a majority voting high reliability system. Figure 7-9 shows the principle schematic for the multi-micro-processor synchronization. The master processor delivers the synchronous signal, output at its $\overline{\text{AS}}$ pin, to the R/W pin of the slave processors. The R/W pin is, under reset status, set to input with a weak (10k Ω typical) pull up resistor. The slave processor(s) synchronizes its internal clock phase with the clock received at its R/W pin. To guarantee the phase synchronization, the reset status must be at least $32 \times 31 = 992$ crystal periods. All the processors must have the same input clock.

ST9 - Reset (ST902x)

RESET (Continued)

Table 7-1. Internal Registers Reset Values

Register Number	System Register	Reset Value	Page 0 Register	Reset Value
F	(SSPLR)	undefined	Reserved	
E	(SSPHR)	undefined	(SPICR)	00h
D	(USPLR)	undefined	(SPIDR)	undefined
C	(USPHR)	undefined	(WCR)	7Fh
B	(MODER)	E0h	(WDTCR)	12h
A	(Page Ptr)	undefined	(WDTPR)	undefined
9	(Reg Ptr 1)	undefined	(WDTLR)	undefined
8	(Reg Ptr 0)	undefined	(WDTHR)	undefined
7	(FLAGR)	undefined	(NICR)	00h
6	(CICR)	87h	(EIVR)	x2h
5	(PORT5)	FFh	(EIPLR)	FFh
4	Reserved		(EIMR)	00h
3	(PORT3)	FFh	(EIPR)	00h
2	(PORT2)	FFh	(EITR)	00h
1	(PORT1)	FFh	Reserved	
0	(PORT0)	FFh	Reserved	

Figure 7-9. Synchronization Under Reset

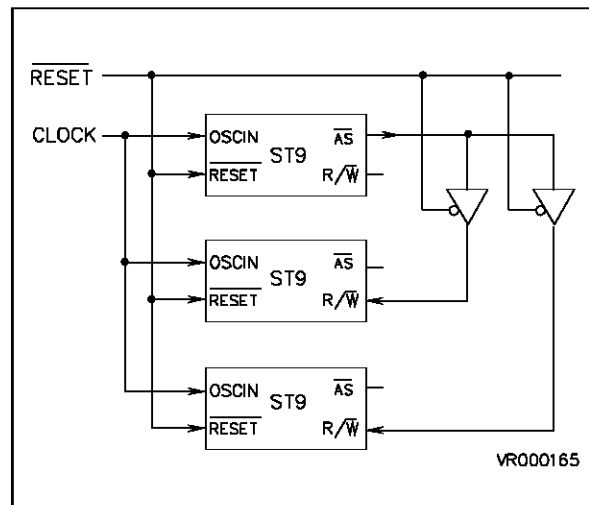

RESET (Continued)

Figure 7-10. Exit From Reset Timing

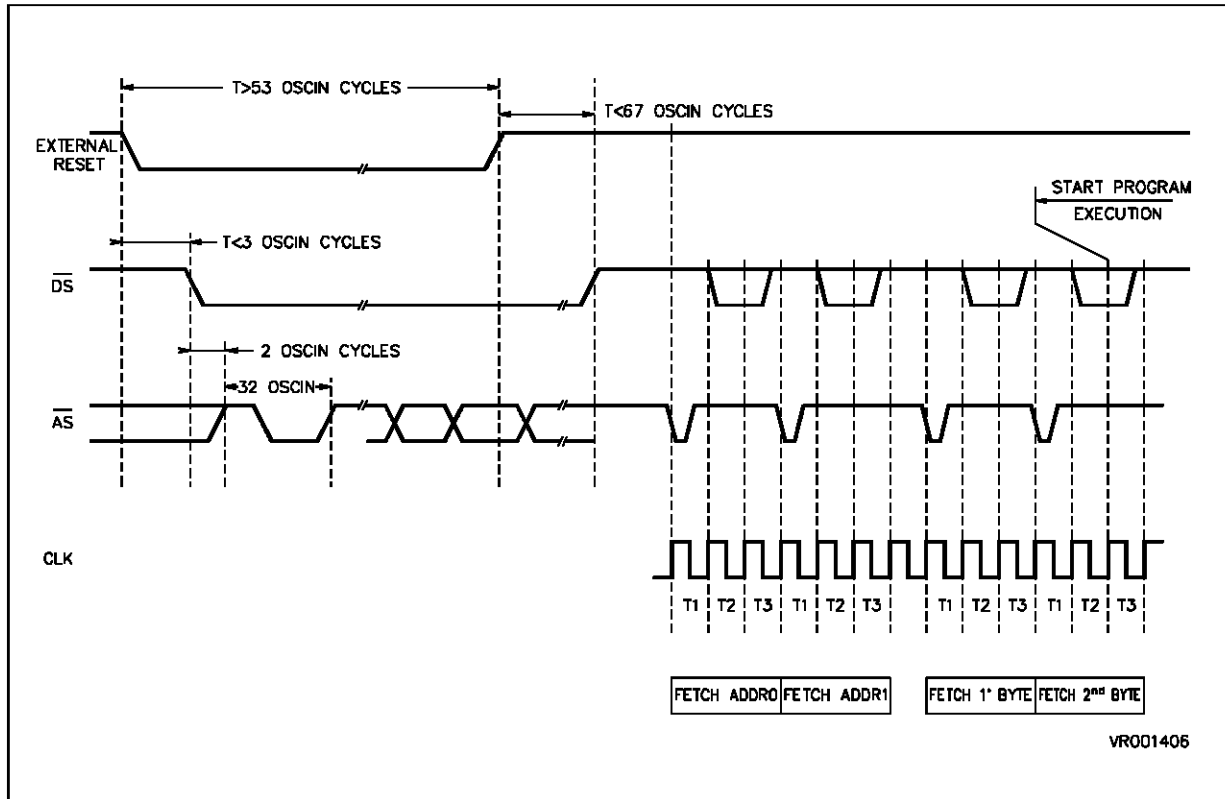

ST9 - Reset (ST902x)

Notes :

8 EXTERNAL MEMORY INTERFACE

8.1 INTRODUCTION

In the event of an application requiring more ROM space than available on-chip, or for easier program management and customization with external memory or peripherals, the ST9 microcontroller provides an external memory interface. The external memory interface provides the memory lines and timing and status control signals, plus enhanced features including programmable memory wait cycles, bus request/acknowledge cycles and shared memory bus access control.

The ST9 Memory Control Unit automatically recognizes if a memory location belongs to on-chip memory. When the memory location is on-chip, it performs a machine cycle without \overline{DS} generation, and the access is performed on-chip. If the location does not belong to on-chip memory, an access to off-chip memory is performed (generating the \overline{DS} low pulse) through the Ports 0, 1 (and 6 for ST905x family).

During Reset, \overline{AS} and \overline{DS} are driven to perform external peripherals reset and to implement, in conjunction with the R/\overline{W} pin, a multi-microprocessor synchronization procedure (see Clock and Reset chapters).

8.2 CONTROL SIGNALS

\overline{AS}

Address Strobe (Output, Active low, Tristate). The rising edge of \overline{AS} indicates that Memory Address, R/\overline{W} and P/\overline{D} Memory signals are valid.

\overline{AS} is released in high-impedance during a Bus acknowledge cycle or under processor control by setting the HIMP bit (MODER.0).

\overline{DS}

Data Strobe (Output, Active low, Tristate). Data Strobe provides the memory data timing during external memory access cycle. When internal memory is accessed, \overline{DS} is kept high during the whole memory cycle. During an External memory write cycle, the data output at Port 0 is valid when \overline{DS} is active. During a read cycle, the data at Port 0 must be valid before the trailing edge of \overline{DS} .

\overline{DS} is released in high-impedance during a Bus Acknowledge cycle or under processor control by setting the HIMP bit (MODER.0).

R/\overline{W}

Read/Write (Output, Active low, Tristate). The R/\overline{W} output signal identifies the type of memory cycle. When $R/\overline{W} = "1"$, the memory cycle is a Memory Read cycle; when $R/\overline{W} = "0"$, it is a Memory Write Cycle. R/\overline{W} output signal is defined at the beginning of the memory cycle and is stable until the next Memory cycle.

R/\overline{W} is released in high-impedance during Bus acknowledge cycle or under processor control by setting the HIMP bit.

P/\overline{D}

Program/Data Memory (Alternate Function Output, Active low). The P/\overline{D} output signal selects between Program and Data Memory. When $P/\overline{D} = "1"$, the memory referenced by the processor is the Program Memory; when $P/\overline{D} = "0"$, the memory referenced is the Data Memory. The P/\overline{D} output signal is defined at the beginning of the memory cycle and is stable until the next Memory cycle.

P/\overline{D} is enabled by software as the Alternate Function output of a parallel port bit (refer to the Pin Configuration and Alternate Function tables to identify the specific port and pin).

WAIT

External Memory Wait (Input, Active low). The \overline{WAIT} input signal indicates to the ST9 that the external memory requires more time to complete the memory access cycle. The memory cycle will then be stretched. \overline{WAIT} is enabled by setting EWEN (EIVR.0 R246 Page 0).

BREQ

Bus Request (Input, Active low). The \overline{BREQ} input signal indicates to the ST9 that a bus request has tried or is trying to gain control of the memory bus. \overline{BREQ} is enabled by setting BRQEN (MODER.1 R235).

BACK

Bus Acknowledge (Alternate Function Output, Active low). The \overline{BACK} output signal indicates that the ST9 has relinquished control of the memory bus in response to a bus request.

ST9 - External Memory Interface (ST902x)

CONTROL SIGNALS (Continued)

P0

Port 0 (Input/Output, Push-Pull/Open-Drain/Weak Pull-up). Port0 can be configured as a bit programmable Parallel I/O port or as External Memory interface for multiplexed Low-Address/Data (A0-7/D0-7).

P1

Port 1 (Input/Output, Push-Pull/Open-Drain/Weak Pull-up). Port1 can be configured as a bit program-

mable Parallel I/O port or as External Memory interface for the High-Address (A8-A15).

P6 (When available)

Port 6 (Input/output, Push-Pull/Open-Drain/Weak Pull-up). This port, when available, can be configured as bit programmable Parallel I/O port or as External Memory interface for the Low-Address (A0-7), allowing a non-multiplexed memory bus capability.

Figure 8-1. ST9 Accessing External Program and Data Memory.

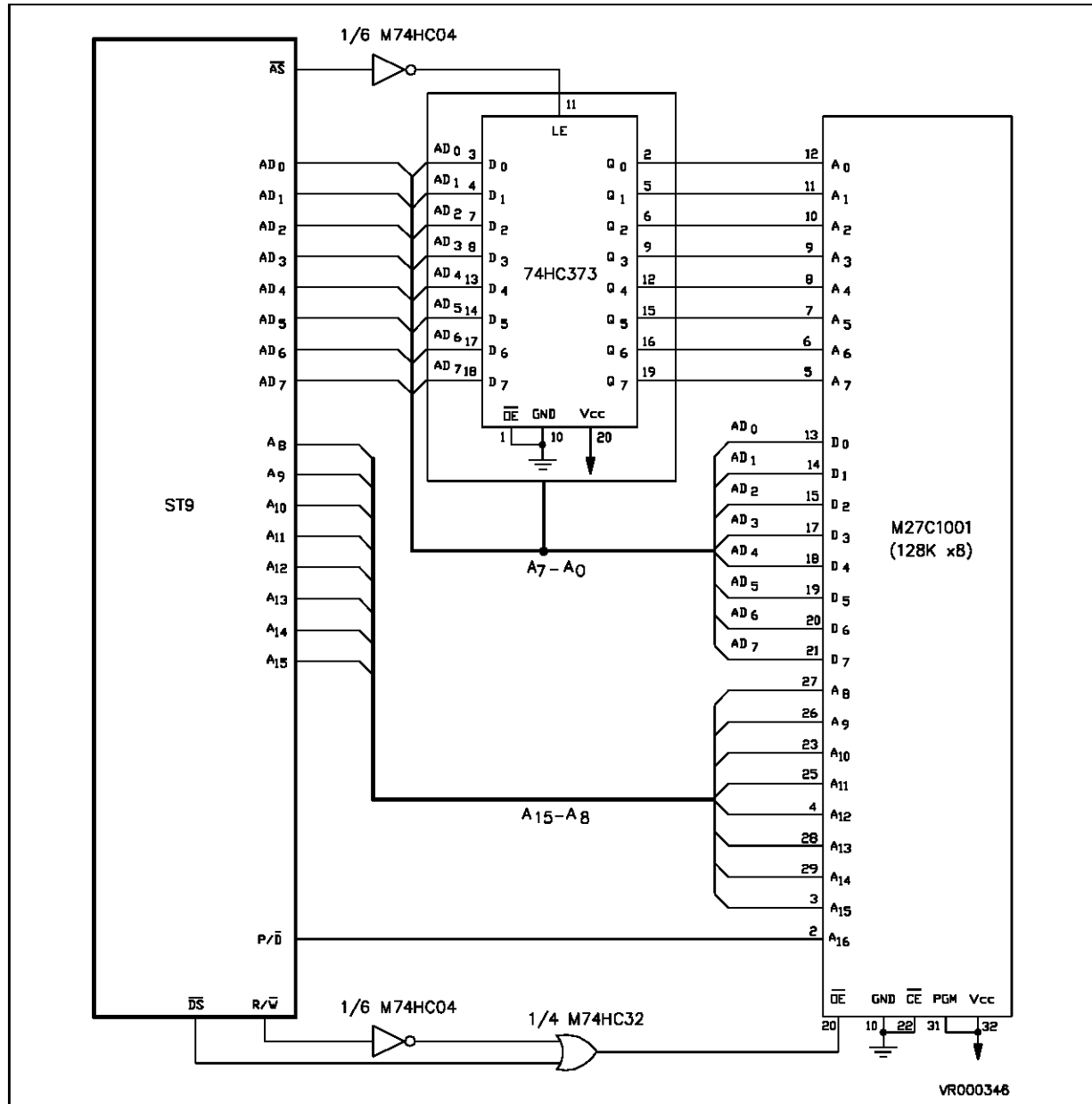

8.3 MEMORY ACCESS CYCLE

Each memory access cycle is composed of three CPUCLK phases: T1, T2, T3. During phase T1, the memory address is output upon \overline{AS} falling edge and is valid upon the rising edge of \overline{AS} . Port1 and Port6 maintain the address stable until the next T1 phase.

If the Memory access cycle is a Read cycle, Port0 pins are released to high impedance with the falling edge of \overline{DS} until the next \overline{AS} falling edge.

If the Memory access is a Write cycle, Port0 is held active, the data is output during T2 and is maintained until the next address is output (upon the falling edge of \overline{AS}). \overline{DS} is pulled low during T2 only if the Memory access is an External Memory access. If the memory cycle is a Memory Read, it is pulled low at the beginning of T2. If it is a Memory Write, \overline{DS} is kept low from the middle of T2 until the middle of T3.

Figure 8-2. External Memory Read/Write.

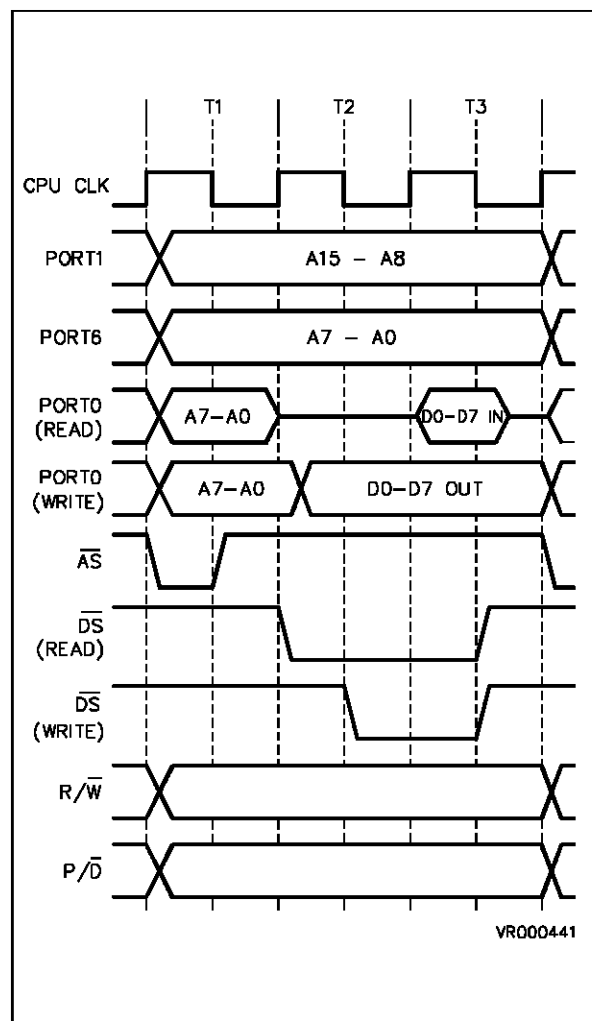

8.4 STRETCHED ACCESS CYCLE

The ST9 can interface to memory with slow access times by automatically inserting additional Wait cycles during the External Memory cycle. On-chip memory accesses do not require WAIT cycles and run at the full speed of CPUCLK.

Three Wait cycle sources are available:

- The input pin WAIT from external sources
- The internal programmable Wait cycle generator
- Internal memories with stretched access cycle

The input pin \overline{WAIT} (when enabled) is sampled on the CPUCLK falling edge of phase T2. If active (low), one INTCLK clock cycle will be added. During the added clock cycle, the \overline{WAIT} pin is sampled again. CPUCLK is stretched for as long as the \overline{WAIT} input is active.

The internal programmable \overline{WAIT} cycle generator allows the extension of the External Memory cycle automatically by the programmed number of WAIT cycles. Two three bit fields in the Wait Control Register WCR (R252 Page 0) allow the stretching of Program and Data Memory access cycles independently by 0 to 7 cycles. WPM2,1,0 (WCR.5,4,1) contain the number of Program memory wait cycles to be added, WDM2,1,0 (WCR.2,1,0) contain the number of Data memory wait cycles to be added.

Table 8-1. Number of wait cycles added

WDM2 WPM2	WDM1 WPM1	WDM0 WPM0	Nb of Clock cycle added	Note
0	0	0	0	No Wait cycle
0	0	1	1	
0	1	0	2	
0	1	1	3	
1	0	0	4	
1	0	1	5	
1	1	0	6	
1	1	1	7	Reset Value

ST9 - External Memory Interface (ST902x)

STRETCHED ACCESS CYCLE (Continued)

Figure 8-3. External Memory Read/Write Sequence with External Wait.

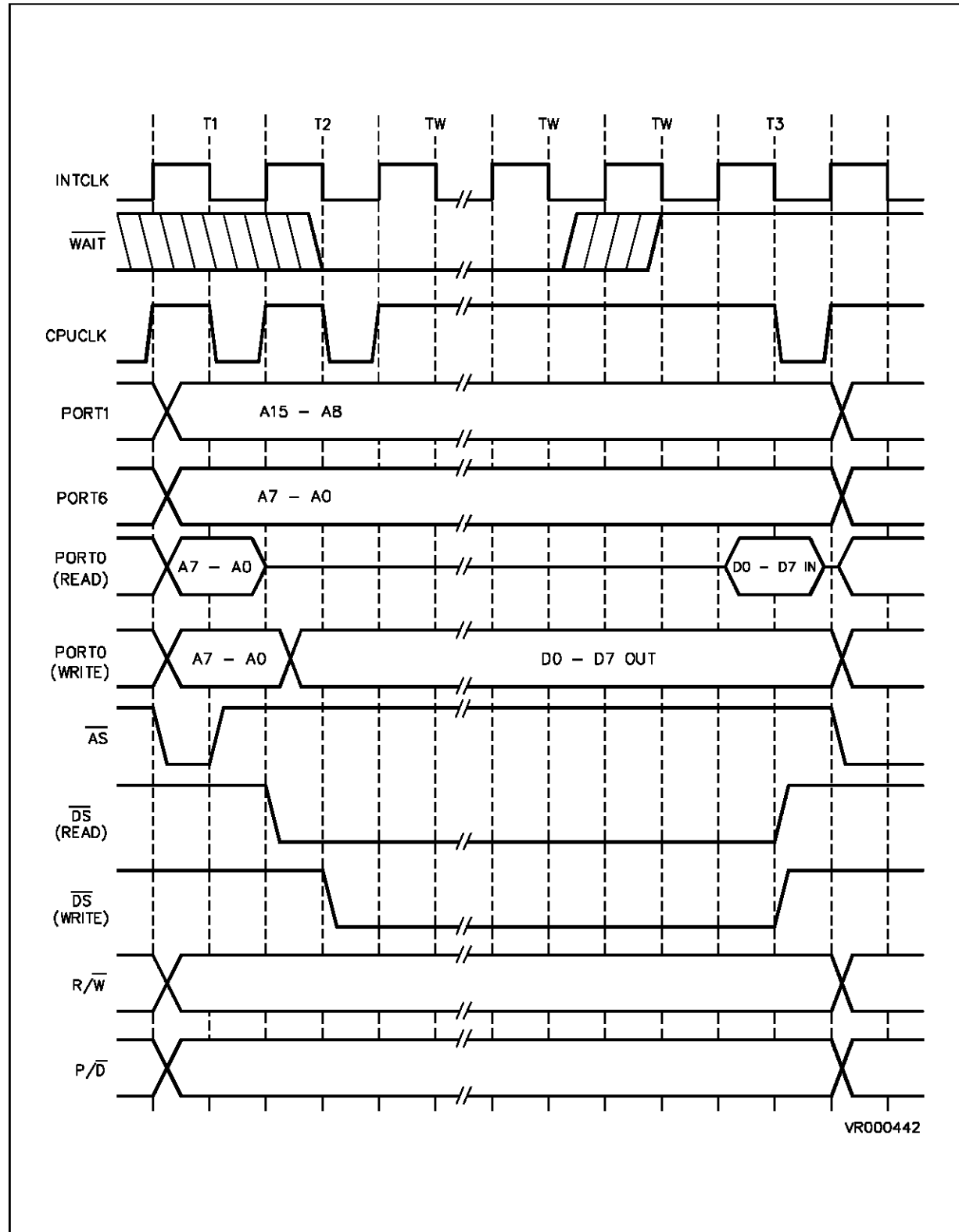

STRETCHED ACCESS CYCLE (Continued)

Figure 8-4. External Memory Read/Write Sequence with Programmable Wait.

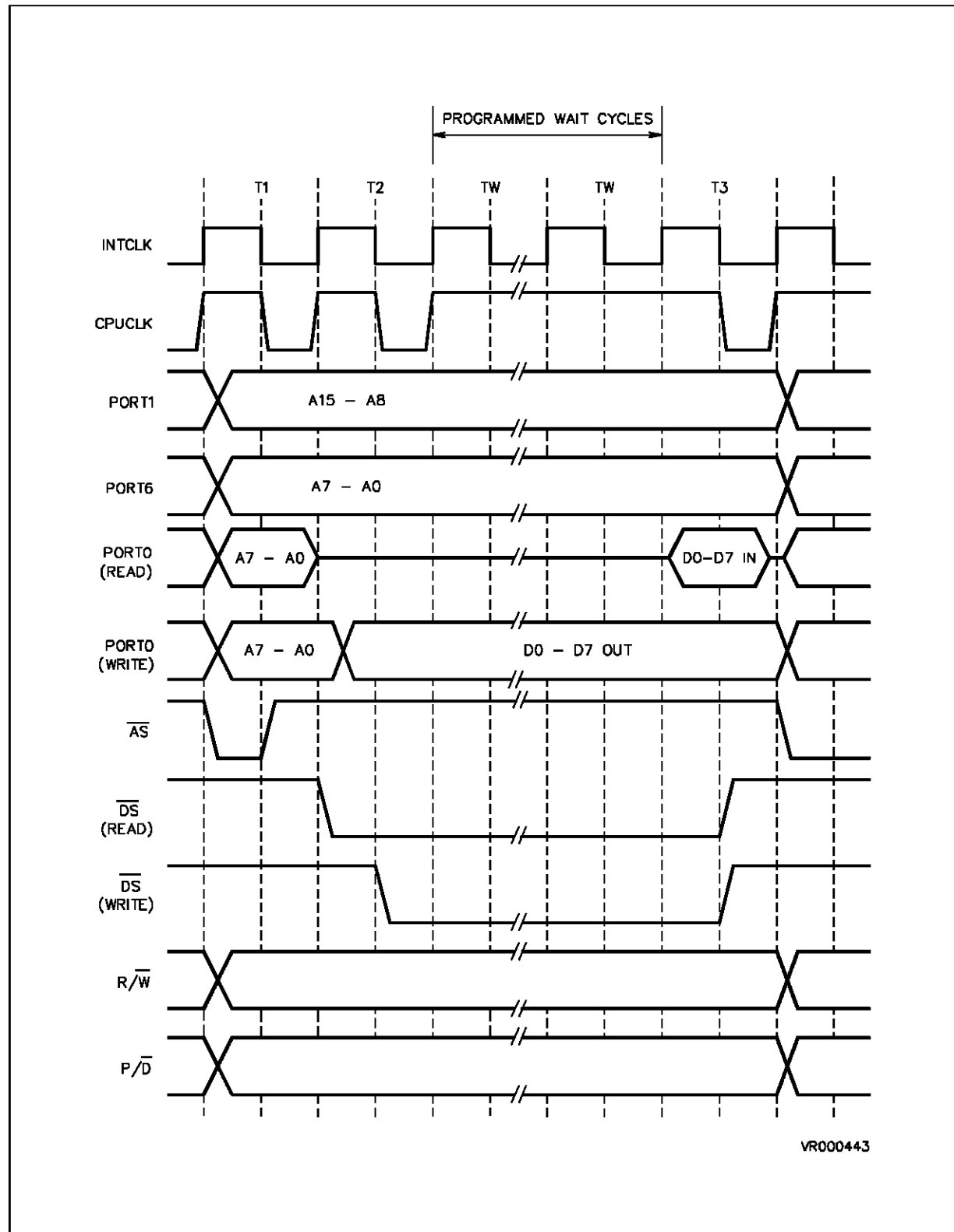

ST9 - External Memory Interface (ST902x)

8.5 SHARED BUS

When the ST9 runs in a multi-master bus system, it is necessary to release the bus control to other bus master(s). This operation can be performed by the Bus Request/Acknowledge capability supported by the ST9.

Once enabled by setting BRQEN (MODER.1 R235), $\overline{\text{BREQ}}$ is sampled by the ST9 upon the falling edge of the internal clock during the phase T3. When the $\overline{\text{BREQ}}$ signal is sampled low, the CPUCLK clock is stretched and the External Memory signals ($\overline{\text{AS}}$, $\overline{\text{DS}}$, $\overline{\text{R/W}}$, P0, P1, P6 for ST905x) are released to high-impedance. The input signal $\overline{\text{BREQ}}$ is then continuously monitored, and when it is sampled high the External Memory interface pins are driven again by the ST9 after two addi-

tional internal clock cycles. These cycles are used to fully drive and propagate the control and data signals through the external memory bus before CPUCLK is restarted.

The output signal $\overline{\text{BACK}}$ is driven low during the whole period when the External Memory interface is released to high impedance.

Under the Reset status, the bits of the I/O port(s) associated to $\overline{\text{BREQ}}$ and $\overline{\text{BACK}}$ are set to Bidirectional Weak pull-up mode and the enable bit BRQEN is cleared. To enable this function, the program must set the $\overline{\text{BACK}}$ port as an Alternate Function output and enable (set to "1") the bit BRQEN.

Figure 8-5. Bus Request/Acknowledge Timing.

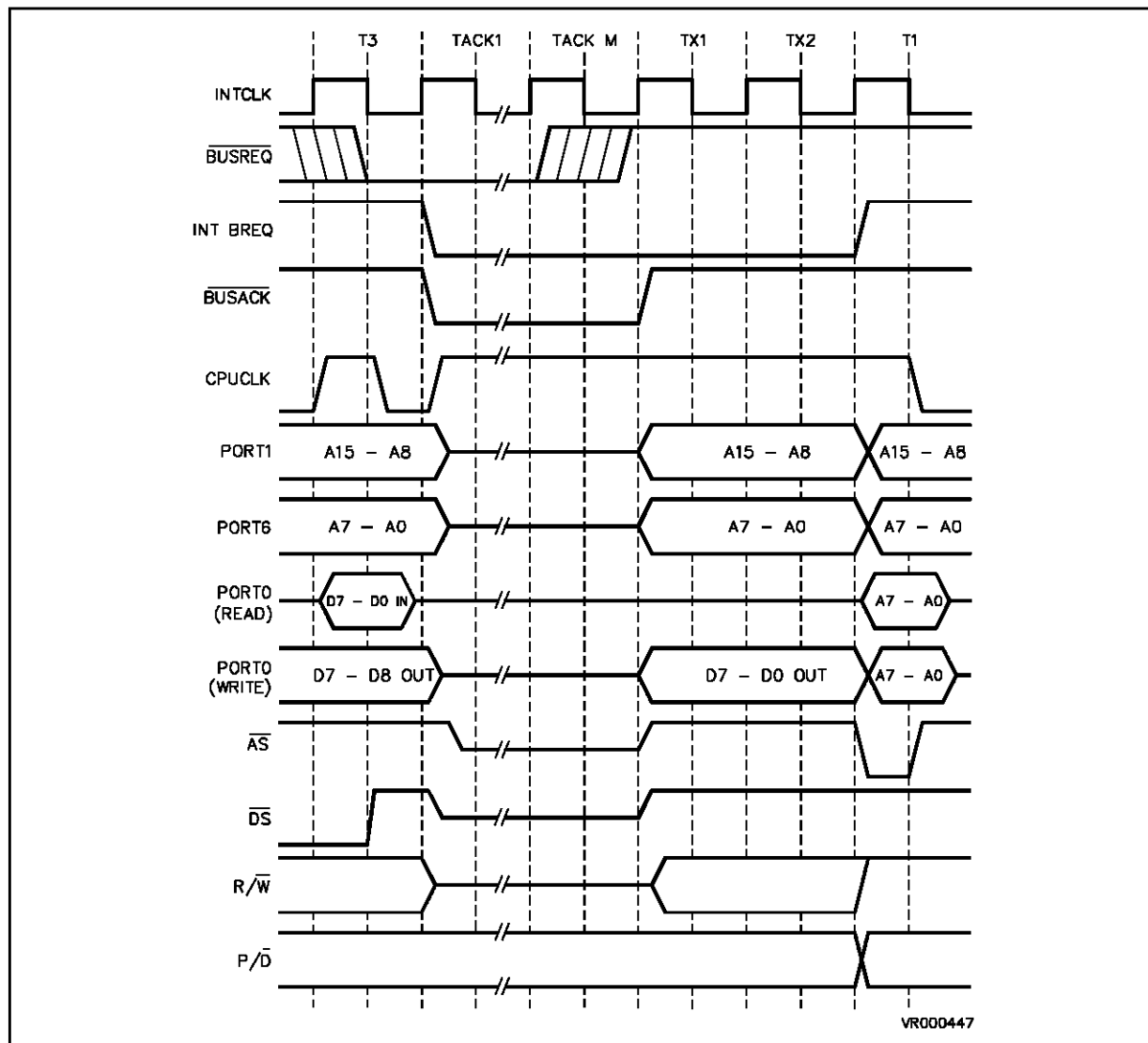

SHARED BUS (Continued)

When it is required to disable the external bus, but to keep the processor running in the on-chip memory, the external memory bus can be disabled by software programming of the HIMP (MODER.0) control bit. By setting HIMP, the External Memory Interface (\overline{AS} , \overline{DS} , R/\overline{W} and Port0, Port1 (and Port6), if not configured as I/O lines) is set into a high impedance state. In this way, the external memory bus can be used by another resource (e.g. diagnostic equipment or external programming of system memories) and the ST9 program can continue accessing the on-chip memory. This feature can also be useful for high security applications where the flow and addresses of the on-chip security algorithms must not be shown on the external address pins.

When running in internal memory, disabling the external bus will reduce the noise emitted by the micro.

The disabling of the External Memory Interface by setting HIMP = "1" can be interrupt driven by applying the "Bus Request" input signal to an External Interrupt pin. In this case the bus disable response time will be longer than the automatic system using the \overline{BREQ} request, however the ST9 can continue to execute the program written in the on-chip memory.

8.6 PORTS P0, P1 INITIALIZATION AFTER RESET

The Port 0 and Port 1 initialization after reset depends on the configuration of the ST9 as shown in Table 8-2.

If the device has on-chip Program memory (ROM or EPROM), the ports (or the existing parts of them) are set to Bidirectional Weak Pull-up Mode.

If the device is ROMLESS or a ROM device with the ROMless function enabled, the ports (or the existing part of them) are set to Alternate Function Push-Pull Mode, providing the Address and Data lines to interface to the external Program and Data Memory from Reset.

Table 8-2. Port status after Reset

Device	Port 0, 1, 6 Initialization
ROM EPROM	Bidirectional Weak-Pull-Up (PxC0, PxC1, PxC2 = 0,0,0; Data = 1)
ROMLESS	Memory Address and Data Alternate Function Push-Pull (PxC0, PxC1, PxC2 = 1,1,0; Data = 1)

ST9 - External Memory Interface (ST902x)

8.7 PIPELINE

The ST9 implements pipe-line stages on instruction fetch and execution in order to increase the execution speed. The instruction execution is in fact hidden by the Memory access cycles: the execution of one instruction is overlapped with the pre-fetch of the two successive bytes. The fetch of the first byte (opcode) is identified by the machine cycle M1, the fetch of the second byte by M2.

The 2 bytes instructions, whose execution time is 6 CPUCLK cycles, have the instruction execution hidden by the following instruction prefetch. For those instructions that require an execution time longer than the time to prefetch the following bytes, perform memory access during their execution or interrupt the sequential memory access, the pipe is flushed.

Figure 8-6. Instruction Pipe-line Stages

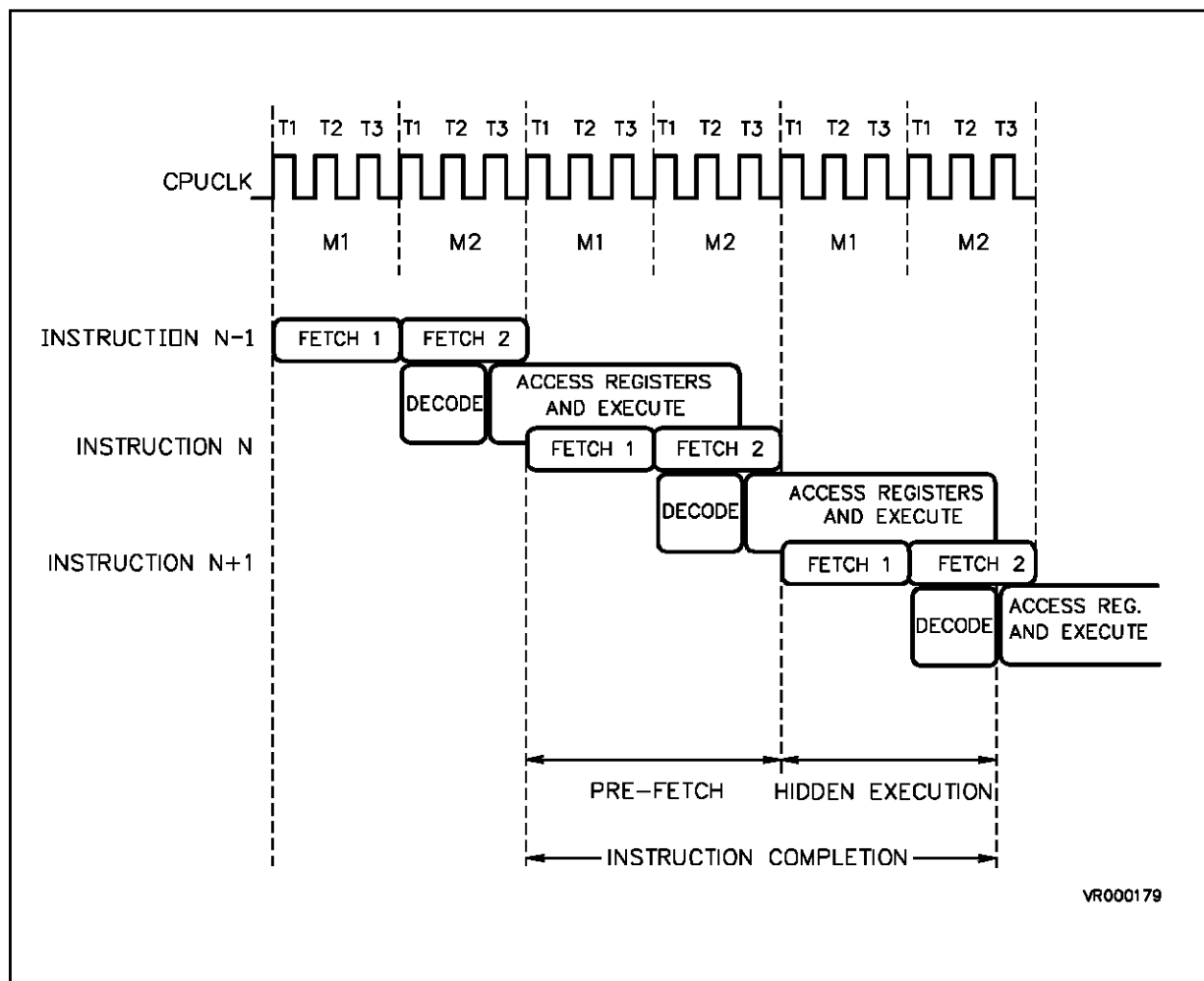

8.8 “SPURIOUS” MEMORY READ ACCESSES

The ST9 in certain cases produces external memory accesses which may be regarded as “Spurious” in their nature. While these do not affect the correct operation of the ST9, these accesses may cause misunderstandings when developing and debugging applications as the signals \overline{AS} and \overline{DS} are produced, and Ports 0, 1, (6 for ST905x) output updated addresses (if used to interface to external memory).

The spurious reading cycle is produced when executing specific instructions. This is one of 4 cases: double reading, reading before writing, reading when the stack is internal or prefetch reading.

- **DOUBLE READING**

A memory location read by the ST9 is read two times consecutively (instead of one).

Involved instruction(s):

`DIV rr,r ; divide (16/8)`

The first byte of the code following `DIV` is fetched two times. The double reading does not occur if the Overflow flag was set by `DIV`, or if Divide by zero was trapped. The P/\overline{D} line remains high during the cycle.

- **READING BEFORE WRITING**

A memory location which is to be written to by the ST9 is previously read.

Involved instruction(s):

`LD (rr)+, (r)+ ;load (byte)
;Memory, Register`

The destination memory location is read before being written. The P/\overline{D} line reflects the memory space of the destination memory location.

- **READING WHEN THE STACK IS INTERNAL**

If the System and/or User Stack has been programmed to use the Register File, a memory location of Data Space is POPed in parallel.

Involved instruction(s):

`POP R ; POP (byte) from System Stack
POP (R) ; " " "
POPU R ; POP (byte) from User Stack
POPU (R) ; " " "`

While a byte is being POPed from the Register File, a memory location in Data Space is read in parallel with its address given by `SSPHR+SSPLR` for `POP` instructions and by `USPHR+USPLR` for `POPU` instructions. The external data is ignored.

`POPW RR ; POP (word) from System Stack`

`POPUW RR ; POP (word) from User Stack`

While the higher address byte is being popped from the Register File, a memory location in Data Space is read in parallel with its address given by `SSPHR+SSPLR` for `POPW` instructions and by `USPHR+USPLR` for `POPUW` instructions. No spurious reading is made for the lower byte.

`RET ; Return from Subroutine`

While the Program Counter Higher and Lower bytes are POPed from the Register File, two memory locations are read at addresses given by `SSPHR+SSPLR`.

`IRET ; Return from Interrupt`

While the Program Counter Higher and Lower bytes and the `FLAGS` are POPed from the Register File, three memory locations are read at addresses given by `SSPHR+SSPLR`. When working with Internal Stacks, `SSPHR` and `USPHR` contents are don't care from the point of view of program execution, but they must be considered RESERVED by the User as the instructions listed in this section perform updating of `SSPHR/USPHR`, together with the spurious reading.

- **PREFETCH READING**

Due to the ST9 Pipeline, instructions which stop the Core or which perform program branches can fetch bytes of the following program code while the pipeline is being flushed.

Involved instruction(s):

`WFI ; Wait For Interrupt`

reads two bytes of the following code.

`HALT ; Halt`

`CALL(rr) ; Unconditional Call subroutine`

read one byte of the following code in Program space (P/\overline{D} high).

ST9 - External Memory Interface (ST902x)

8.9 REGISTERS

WCR R252 (FCh) Page 0 Read/Write
Wait Control Register

Reset Value: 0111 1111 (7Fh)

7							0
X	WDGEN	WDM2	WDM1	WDM0	WPM2	WPM1	WPM0

b7 = Reserved, reads as a "0".

b6 = **WDGEN**: refer to Timer/Watchdog chapter.

WARNING. Resetting this bit to zero has the effect of setting the Timer/Watchdog to the Watchdog mode. Unless this is desired, this must be set to "1".

b5-b3 = **WDM2-0: Data Space Wait Cycles.** These bits contain the number of INTCLK cycles to be added automatically to external Data memory accesses. WDM = 0 gives no additional wait cycles, WDM = 7 provides the maximum 7 INTCLK cycles (this is the reset condition in order to allow the use of slow access time external memory, if faster memory is used, then this value may be modified by the User).

b2-b0 = **WPM2-0: Program Space Wait Cycles.** These bits contain the number of INTCLK cycles to be added automatically to external Program memory accesses. WPM = 0 gives no additional wait cycles, WPM = 7 provides the maximum 7 INTCLK cycles (this is the reset condition in order to allow the use of slow access time external memory, if faster memory is used, then this value may be modified by the User).

Note. the number of clock cycles added refer to INTCLK and NOT to CPUCLK.

WARNING. The Wait Control Register is reset to give the maximum number of Wait cycles for external memory. To give the optimum performance of the ST9 when used in single-chip mode (no external memory) the WDM2,1,0 and WPM2,1,0 bits should be reset to "0".

9 I/O PORTS

9.1 INTRODUCTION

The ST9 is provided with dedicated lines for input/output. These lines, grouped into 8-bit ports, can be independently programmed to provide parallel input/output, or to carry input/output signals to/from the on-chip peripherals and Core (e.g. Timers and SCI). All ports have active pull-ups and pull-down resistors compatible with TTL loads. In addition, pull-ups can be turned off for open-drain operation and weak pull-ups can be turned on to save off-chip resistive pull-ups. Input buffers can be either TTL or CMOS compatible.

9.2 CONTROL REGISTERS

Each port PX has a Data Register PX, and three associated control registers (PXC0, PXC1, PXC2) which define the port line configuration and allow dynamic change in port configuration during program execution. Ports and control registers are mapped into the Register File as shown in Figure 9-1. Ports and control registers are treated like any other general-purpose register. There are no special instruction for port manipulation, any instruction that addresses a register can address the ports. Data can be directly accessed in the port register, without passing through other memory or "accumulator" locations.

Figure 9-1. I/O Register Map

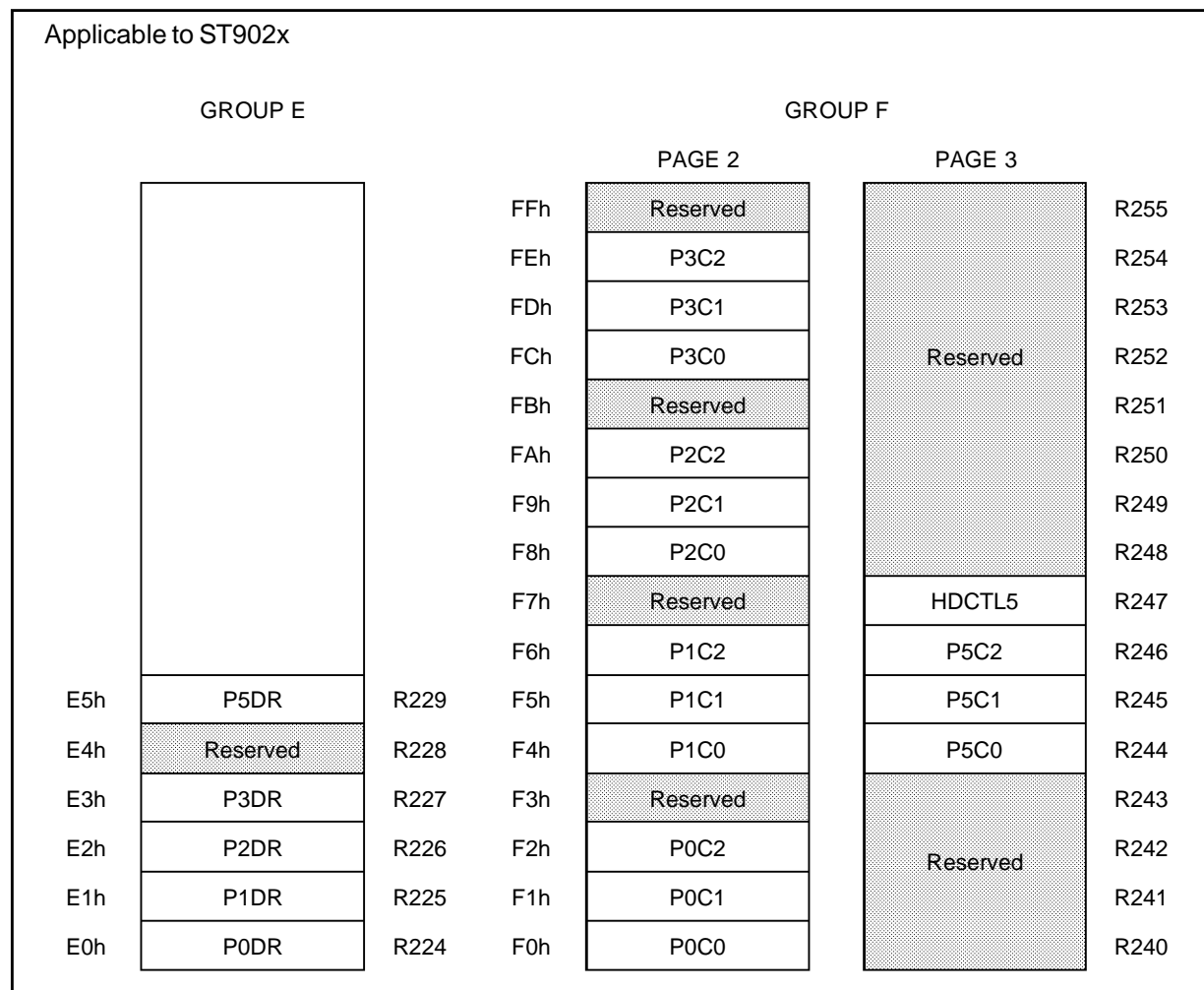

ST9 - I/O Ports (ST902x)

CONTROL REGISTERS (Continued)

During the reset state, all the Ports are set as bidirectional/weak pull-up mode, with the output data register set to FFh. This condition is also held after reset (except for Ports 0, 1, 6 for ST905x) in ROM-less devices, see Memory chapter) and can be re-defined under software control at any time.

9.3 PORT BIT STRUCTURE AND PROGRAMMING

By programming the control bits PXC0.n and PXC1.n (see Figure 9-2) it is possible to configure bit PX.n as Input, Output, Bidirectional or Alternate Function Output, where X is the number of the I/O port, and n the bit within the port (n = 0 to 7).

When programmed as input, it is possible to select the input level as TTL or CMOS by programming the control bit PXC2.n.

The output buffer can be programmed as Push-pull or Open-drain. A Weak Pull-up configuration can be used when the port bit is programmed as Bidirectional. This is an Open-drain configuration with a high pull-up resistor value (turned on by writing a "1"), to avoid the requirement for external resistances.

The basic structure of the bit PX.n of a general purpose port PX is shown in Figure 9-3.

Independently to the chosen configuration, when the User addresses the port as a destination register of an instruction, the port is written to and the data is transferred from the internal Data Bus into the Output Master Latches. When the port is addressed as a source register for an instruction, the port is read and the data stored in the Input Latch is transferred onto the internal Data Bus.

When PX.n is programmed as Input: (Figure 9-4)

- The Output Buffer is forced tristate
- The data present on the I/O pin is sampled into the Input Latch at the beginning of the execution of the instruction which is accessing the port.
- The data stored in the Output Master Latch is copied into the Output Slave Latch at the end of the execution of each instruction. So if bit PX.n is reconfigured as Output or Bidirectional, the data stored in the Output Slave Latch is reflected on the I/O pin.

Figure 9-2. Control Bits

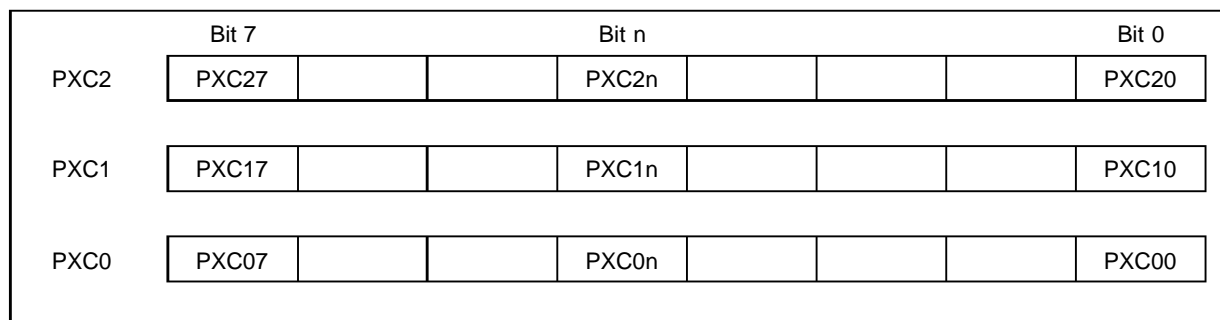

Table 9-1. Port Bit Configuration Table

PXC2n	0	1	0	1	0	1	0	1
PXC1n	0	0	1	1	0	0	1	1
PXC0n	0	0	0	0	1	1	1	1
PXn Configuration	BID	BID	OUT	OUT	IN	IN	AF	AF
PXn Output	WP	OD	PP	OD	HI	HI	PP	OD
PXn Input	TTL	TTL	TTL	TTL	CMOS	TTL	TTL	TTL

Legend:

X = Port OD = Open Drain
n = Bit WP = Weak Pull-up
AF = Alternate Function
HI = High Impedance

PP = Push-Pull
BID = Bidirectional

TTL = TTL Standard Input
CMOS = CMOS Standard Input
IN = Input
OUT = Output

PORT BIT STRUCTURE AND PROGRAMMING (Continued)

Figure 9-3. Basic Structure of an I/O Port Pin

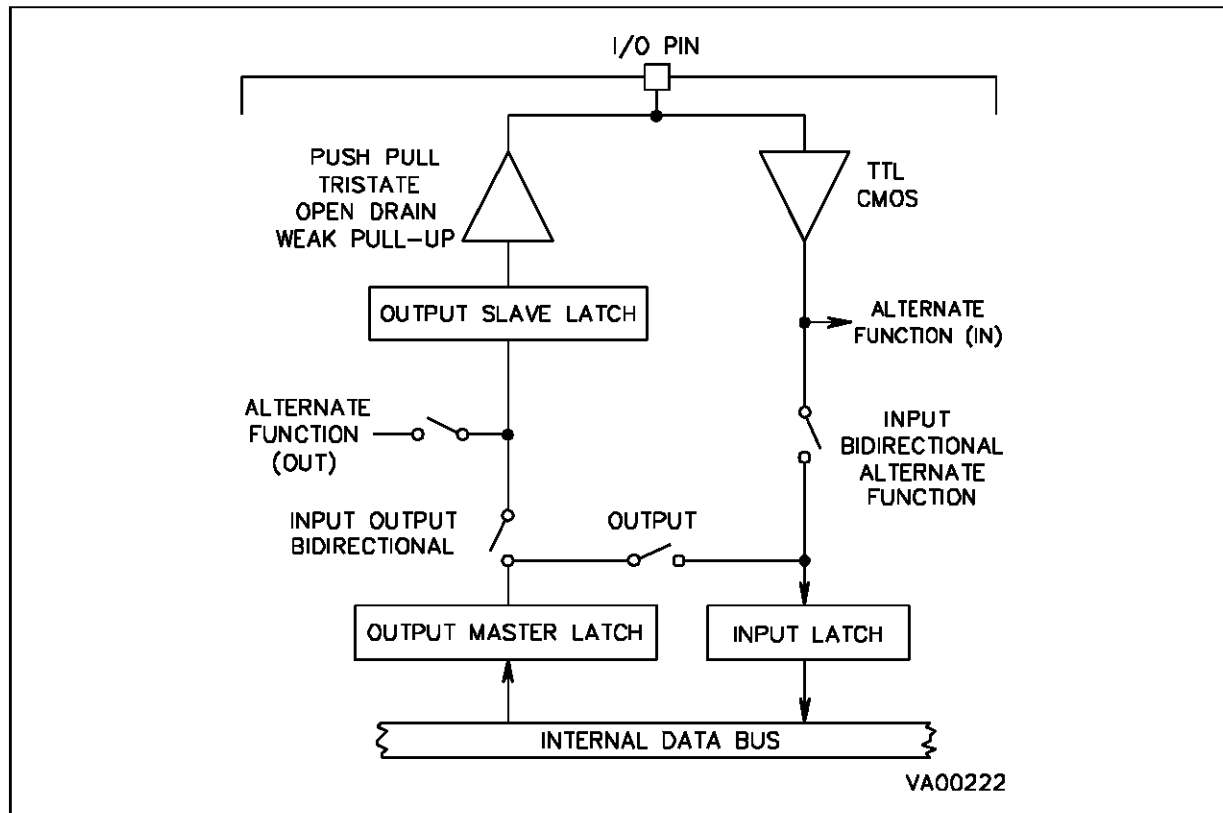

Figure 9-4. Input Configuration

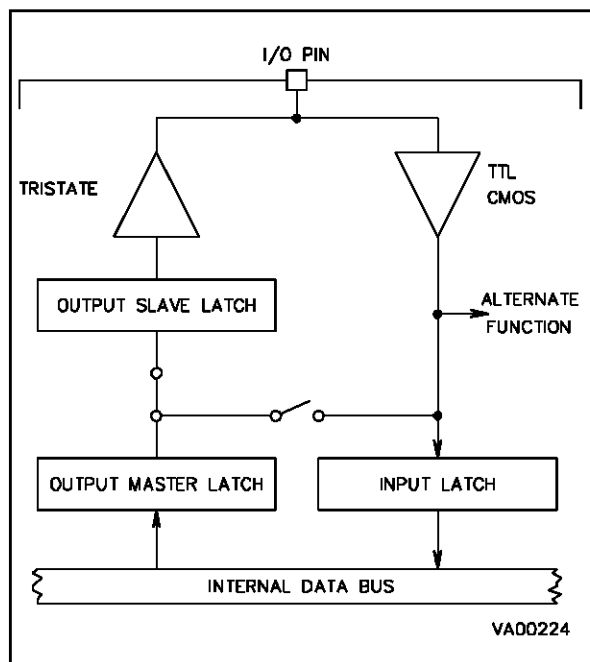
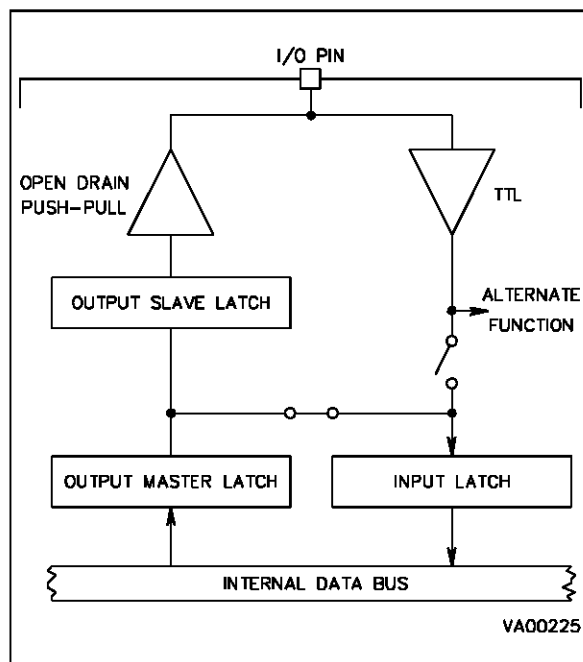

Figure 9-5. Output Configuration



PORT BIT STRUCTURE AND PROGRAMMING (Continued)

When PX.n is programmed as Output: (Figure 9.5)

- The Output Buffer is turned on in an Open-drain or Push-pull configuration
- The data stored in the Output Master Latch is copied both into the Input Latch and into the Output Slave Latch, driving the I/O pin, at the end of the execution of each instruction.

When PX.n is programmed as Bidirectional: (Figure 9-6)

- The Output Buffer is turned on in an Open-drain or Weak Pull-up configuration
- The data present on the I/O pin is sampled into the Input Latch at the beginning of the execution of each instruction
- The data stored in the Output Master Latch is copied into the Output Slave Latch, driving the I/O pin, at the end of the execution of each instruction.

WARNING. Due to the unique feature of the bidirectional mode of reading the external pin instead of the output latch, particular care must be taken with arithmetic/logic and boolean instructions performed on a bidirectional port pin.

These instructions use a read-modify-write sequence, and the result written in the port register depends on the logical level present on the external pin.

This may bring unwanted modifications to the port output register content.

For example:

Port register content	external port value
0Fh	03h

(Bits 3 and 2 are externally forced to 0)

Making a `bset` instruction on bit 7 will return:

Port register content	external port value
83h	83h

(Bits 3 and 2 have been cleared.)

To avoid this situation, it is suggested that all the operations on a port, using at least one bit in bidirectional mode, are performed on a copy of the port register, then transferring the result with a load instruction to the I/O port.

When PX.n is programmed as Alternate Function Output (Figure 9-7) except for Analog Inputs :

- The Output Buffer is turned on in an Open-drain or Push-pull configuration
- The data present on the I/O pin is sampled into the Input Latch at the beginning of the execution of each instruction
- A signal coming from an on-chip Function is allowed to load the Output Slave Latch driving the I/O pin. Signal timing is under control of the Function. If no Function is connected to PX.n the I/O pin is driven to a high level in Push-pull configuration and is driven to high impedance in open drain configuration.

Figure 9-6. Bidirectional Configuration

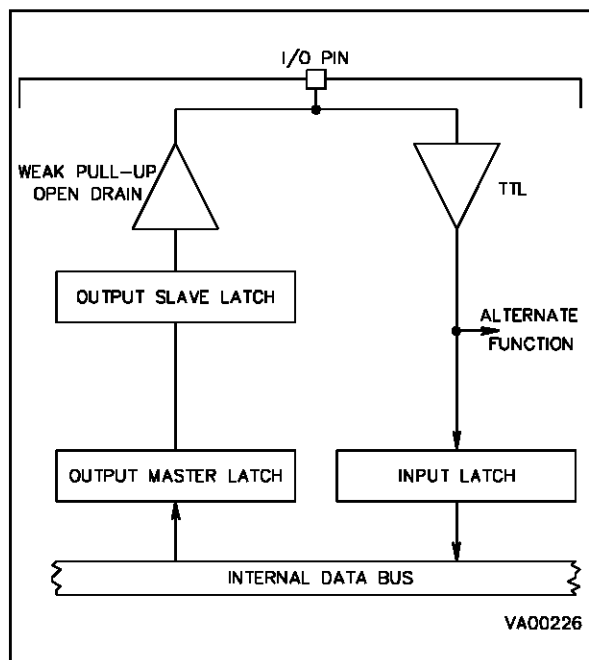
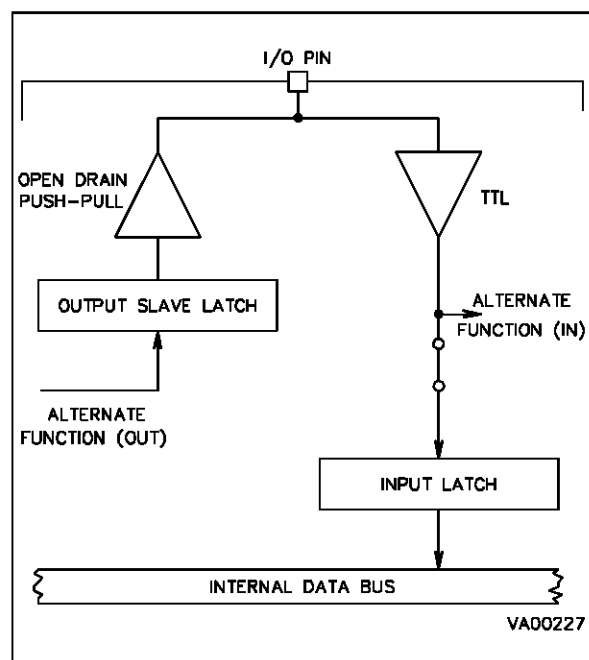

Figure 9-7. Alternate Function Configuration



9.4 ALTERNATE FUNCTION ARCHITECTURE

Each single I/O pin may access three different types of ST9 internal signals:

- Data bus line (I/O)
- 'Alternate Function' Input
- Alternate Function Output

Each pin configuration is made by software, thus allowing the User to choose the type of signal to access a pin. The choice of type of signal is made with the registers PXC2, PXC1, PXC0 of the I/O Port X (Please refer to the previous section for more details)

Pins Declared as an I/O

A pin declared as an I/O is a pin connected to the I/O buffer. In such a case, this pin may either be an Input or an Output or an I/O depending on the value stored in (PXC2, PXC1, PXC0)

Figure 9-8. Example of 3 Alternate Function Inputs

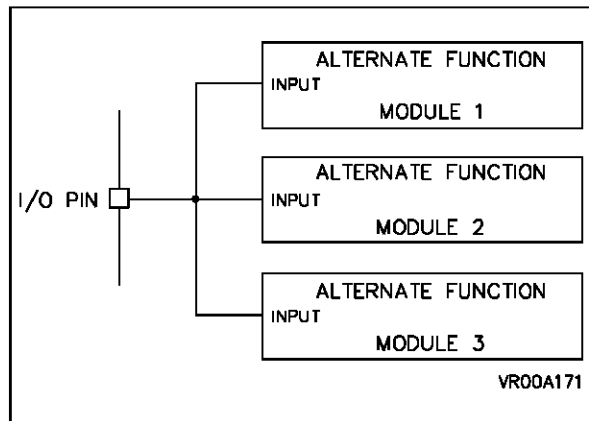
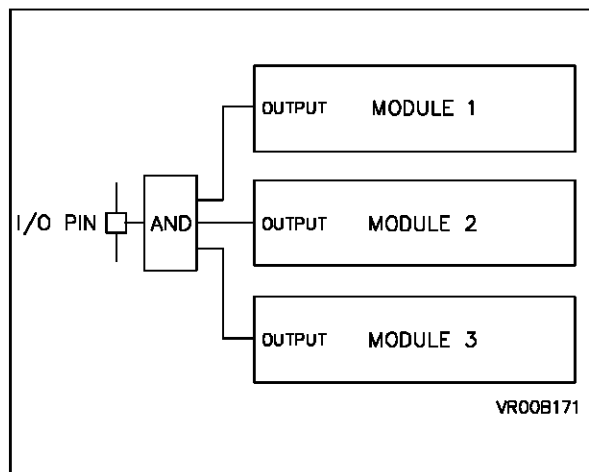

Figure 9-9. Example of 3 Alternate Function Outputs



Pin Declared As An 'Alternate Function' Input

A single pin may be directly connected to several Alternate Function inputs. In such a case, the User has to select the required input mode (TTL or CMOS levels) and to enable, by software, the selected Alternate Function module (by enabling it) and unselect all other Alternate Functions (by disabling them).

No specific configuration of the port is required to enable the input Alternate Function, as the input buffer is directly connected to each module using it. As more than one module can use the same input Alternate Function line, it is under User software control to enable a module to use the input Alternate Function.

The digital I/O remains operational even when using the Alternate Function input. The exception to this is for an I/O port bit connected to analog voltages (for the Analog to Digital Converter - R50 only).

Pin Declared As An Alternate Function Output

A pin declared as an Alternate function output corresponds to (PXC2,PXC1,PXC0) = 1,1,1 or 0,1,1. Several Alternate Function outputs may drive a common pin. In such a case, the Alternate Function output signals are ANDed before driving the common pin. The User has therefore to select, by software, the Alternate Function Output required by enabling it and disabling all other Alternate Function Outputs on the same pin (a disabled Alternate Function Output outputs a "1").

The inputs to on-chip Functions and Alternate Function Outputs are predefined for each I/O pin of an ST9. Please refer to the Alternate Function Table at the beginning of this datasheet for the exact configuration.

Figure 9-10. Example of One I/O Pin Configuration

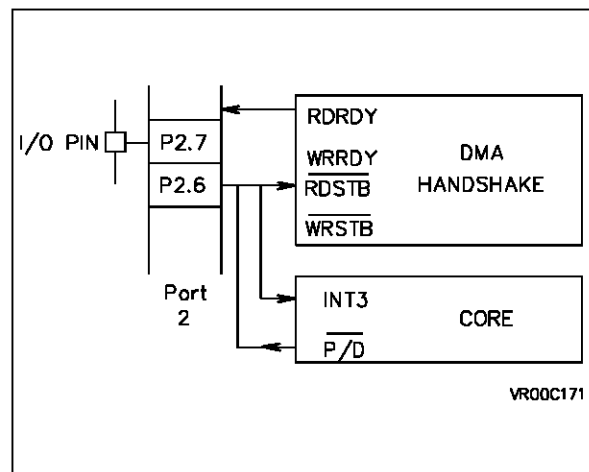

ST9 - I/O Ports (ST902x)

ALTERNATE FUNCTION (Continued)

General Configuration

A single pin may be used, according to different phases of the software, as an I/O or connected to an input or an Alternate Function output. An example is given in Figure 9-10.

WARNING: When a pin is connected to an Input Function and to an Alternate Function output, the User must be aware of the fact that the Alternate Function output signal always input to the Alternate Function module(s) declared as input(s).

Figure 9-10 shows an example where the signal P/D also enters RDSTB and INT3.

9.5 I/O STATUS AFTER WFI, HALT AND RESET

The status of the ST9 I/O ports during the Wait For Interrupt, Halt and Reset operational modes is shown in the following table. The External Memory Interface ports are shown separately, however, if only the internal memory is being used and the ports are acting as I/O, the status is the same as shown for the other I/O ports.

WARNING: I/O pins are set to the Weak Pull-up mode during the Reset cycle. This state is forced during the reset sequence, but the I/O pins can be in a random state for up to 64 crystal periods. The application circuit must take this into account if this can lead to critical situations in the external circuitry.

Mode	P0	P1, P6	I/O
WFI	High Impedance	Next Address	No Affect (clocks output from ST9 running)
HALT	High Impedance	Next Address	No Affect (clocks output from ST9 stopped)
RESET			Bidirectional Weak Pull-up

10 HANDSHAKE/DMA CONTROLLER

10.1 INTRODUCTION

The handshake module allows the User to configure an I/O Port under handshake control or to support DMA operations, driven by an on-chip 16 bit Multifunction TIMER, between Data/Program Memory or Register File and an I/O port.

The module supports data exchange with handshake through port PX (where PX is predefined by the ST9 configuration) with up to 4 handshake lines: 2 Outputs (RDRDY and WRRDY) connected as Alternate Function Outputs and 2 Inputs (RDSTB and WRSTB).

Input, Output and Bidirectional Handshake modes are available.

Input Functions \overline{RDSTB} and \overline{WRSTB} are always associated to external interrupt channels. To synchronize handshake protocols generating interrupt

requests (as the following paragraph will show) the User must program the interrupt control register and the vector associated to the used line(s) (\overline{RDSTB} and/or \overline{WRSTB}). The active high output lines RDRDY and WRRDY are held high when not active in order to allow the Alternate Function Output connection of other ST9 peripherals.

DMA transfers can move data from Data/Program Memory or Register File to the I/O Port with Handshake capability or viceversa, using either the Multifunction Timer CAPT0 or COMP0 DMA Channels. In Figure 10-1 the four on-chip lines that connect the module to the on-chip Multifunction Timer to support DMA transfers are shown (DD (Data Direction), CO_SYNCHR(COmpare SYNCHronism), CA_SYNCHR (CApture SYNCHronism) and On Chip Event).

Figure 10-1. Handshake/DMA Controller Module Block Diagram

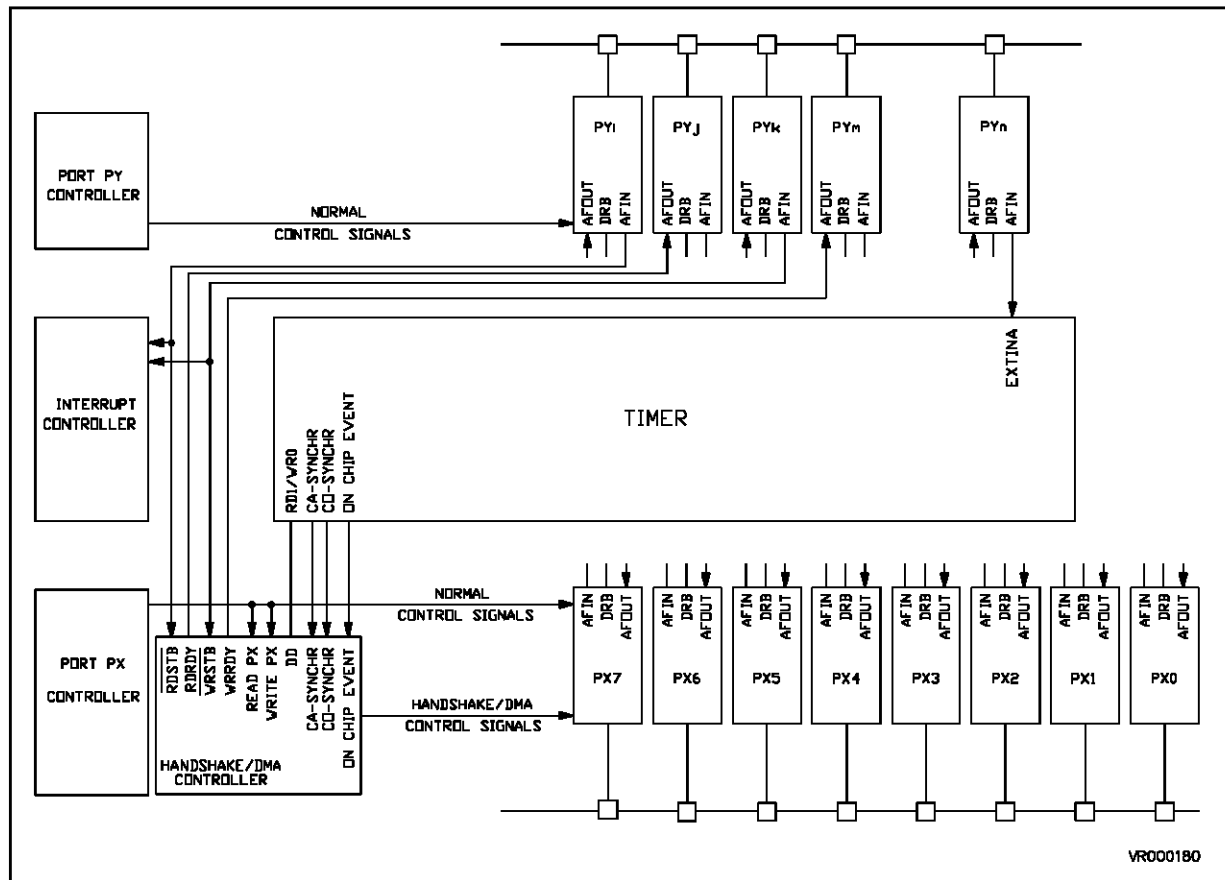

ST9 - Handshake (ST902x)

10.2 PROGRAMMABLE HANDSHAKE MODES

10.2.1 Input Handshake

Two Input Handshake Modes are available to synchronise input transitions on port bits programmed as Input or Bidirectional. Output or Alternate Function bits are not affected.

In the timings, READ PORT is an ST9 internal signal that transfers data from the Input Latches onto the Data bus.

Two Lines Input Handshake

When this mode is selected WRRDY is set to indicate that data can be loaded into the Input Latches of the Input and Bidirectional port pins. Data present on the pins is read when the peripheral forces a low level on $\overline{\text{WRSTB}}$ and is sampled on the rising edge of $\overline{\text{WRSTB}}$.

When a rising edge on $\overline{\text{WRSTB}}$ occurs, WRRDY goes low signifying that the Input Latch is full and further loading must be inhibited until the ST9 reads the port. When the port register is read, WRRDY is set. Both low and high levels on $\overline{\text{WRSTB}}$ must last at least one INTCLK cycle.

The User is suggested to program the External Interrupt Channel associated with the $\overline{\text{WRSTB}}$ line to generate an interrupt request when a rising edge occurs. The ST9 can thus, in the course of its interrupt service routine, read the data furnished by the peripheral as soon as it is available.

Figure 10-2. Two Line Input Handshake

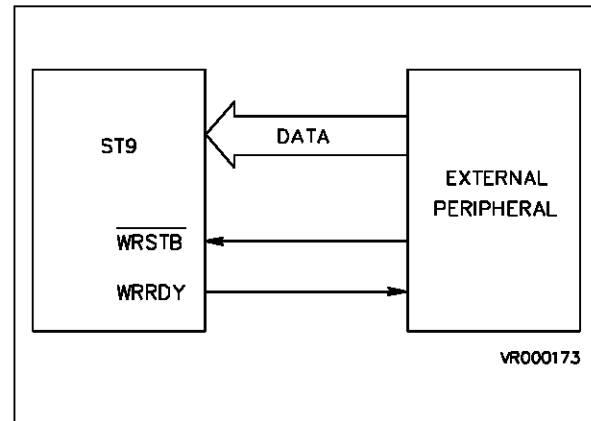
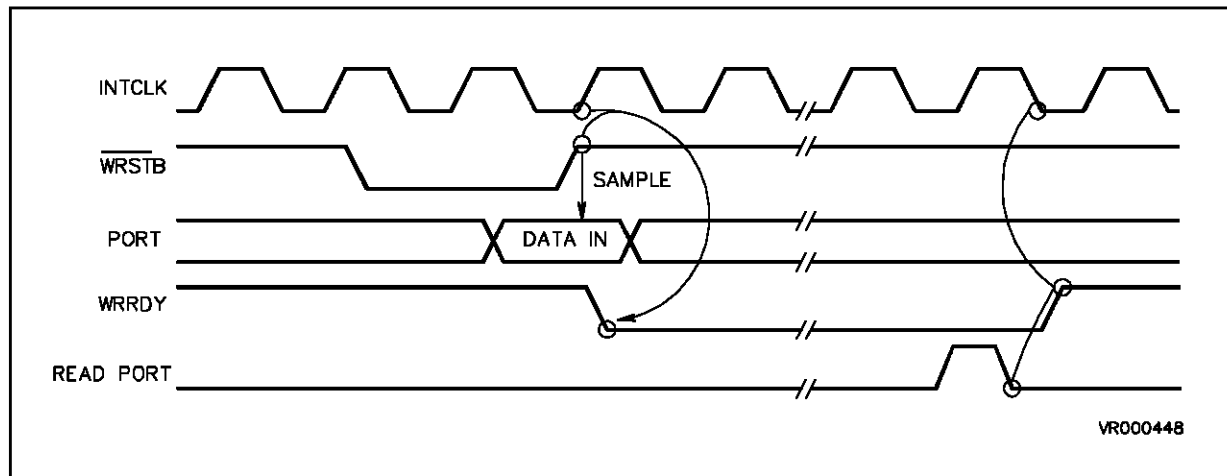

Figure 10-3. Two Line Input Handshake Timing



HANDSHAKE MODES (Continued)

One Line Input Handshake

Figures 10-4 and 10-5 illustrate the timing associated with the One Line (WRRDY) Input Handshake Mode.

When this mode is selected the ST9 sets WRRDY to indicate that data can be loaded into the Input Latches of the Input and Bidirectional port pins.

Data present on the pins is continuously sampled. When the ST9 is reading the port WRRDY goes low. As data is strobed into the port only when WRRDY goes high, the forced low state of WRRDY will prevent the Input Latch data from changing while ST9 is reading the port. When the ST9 read cycle finishes, WRRDY is set.

Figure 10-4. One Line Input Handshake

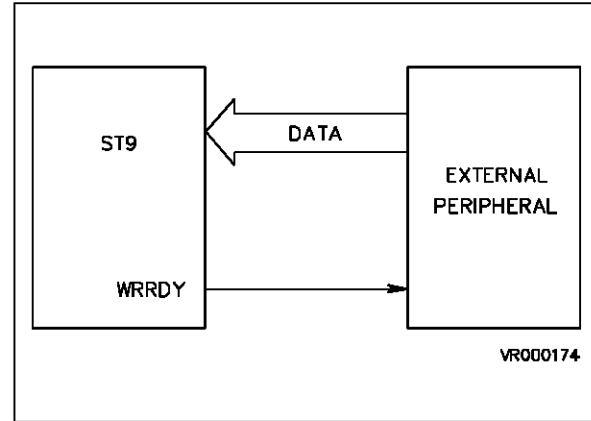
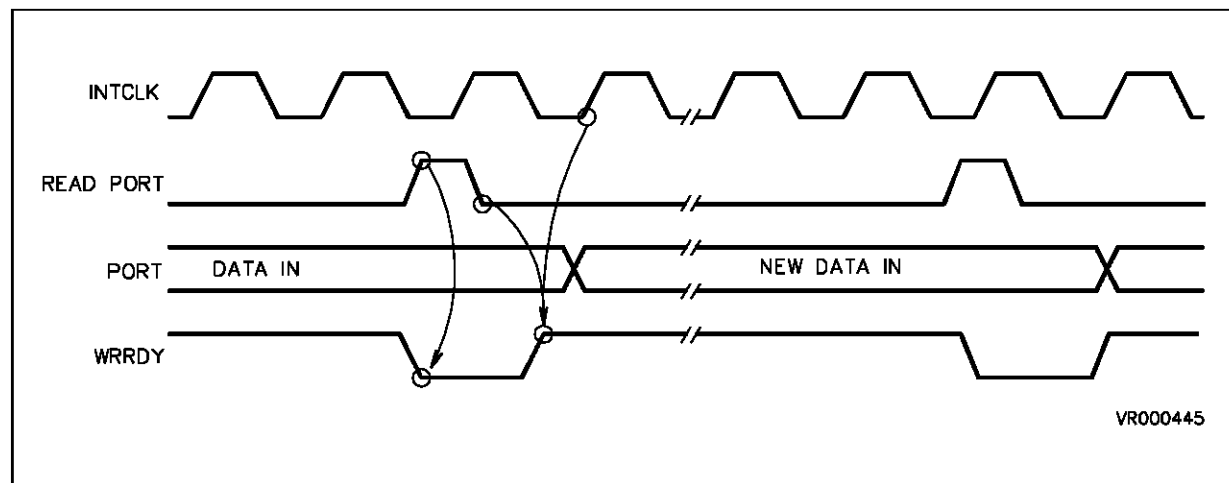

Figure 10-5. One Line Input Handshake Timing



ST9 - Handshake (ST902x)

HANDSHAKE MODES (Continued)

10.2.2 Output Handshake

Two Output Handshake Modes are available to synchronize output transitions on port bits programmed as Output or Bidirectional. I/O pins programmed as Input or Alternate Function Output are not affected.

In the timing diagrams, WRITE PORT is the internal signal that transfers data from the Internal Data Bus into the Port Output Master Latches.

Two Lines Output Handshake

Figure 10-7 illustrates the timing associated with the Two Lines (RDRDY, $\overline{\text{RDSTB}}$) Output Handshake Mode (Figure 10-6).

When this mode is selected RDRDY is reset to indicate that no significant data is present on the Output and Bidirectional port pins. When the Output Slave Latches are written, RDRDY is set to indicate that data is ready for the peripheral device. In most systems the rising edge of RDRDY can be used as a latching signal in the peripheral device. RDRDY will remain high until a rising edge is received on $\overline{\text{RDSTB}}$ indicating that the peripheral has taken the data. Both low and high level on

$\overline{\text{RDSTB}}$ must last at least one ST9 INTCLK cycle. The User is suggested to program the External Interrupt Channel associated with the $\overline{\text{RDSTB}}$ line to generate an interrupt request when a rising edge occurs. The ST9 can thus, in the course of its interrupt service routine, furnish new data as soon as the previous data is taken by the peripheral.

Figure 10-6. Two Line Output Handshake

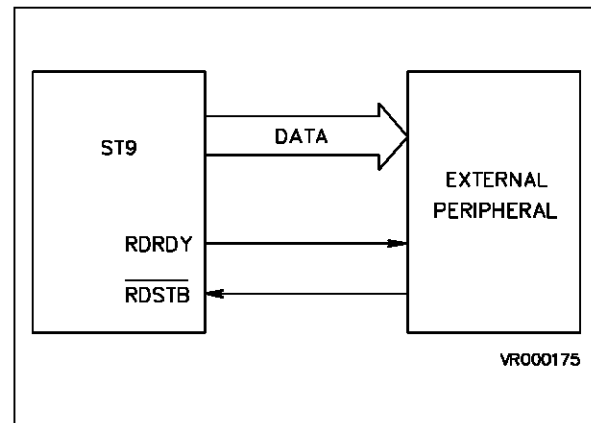
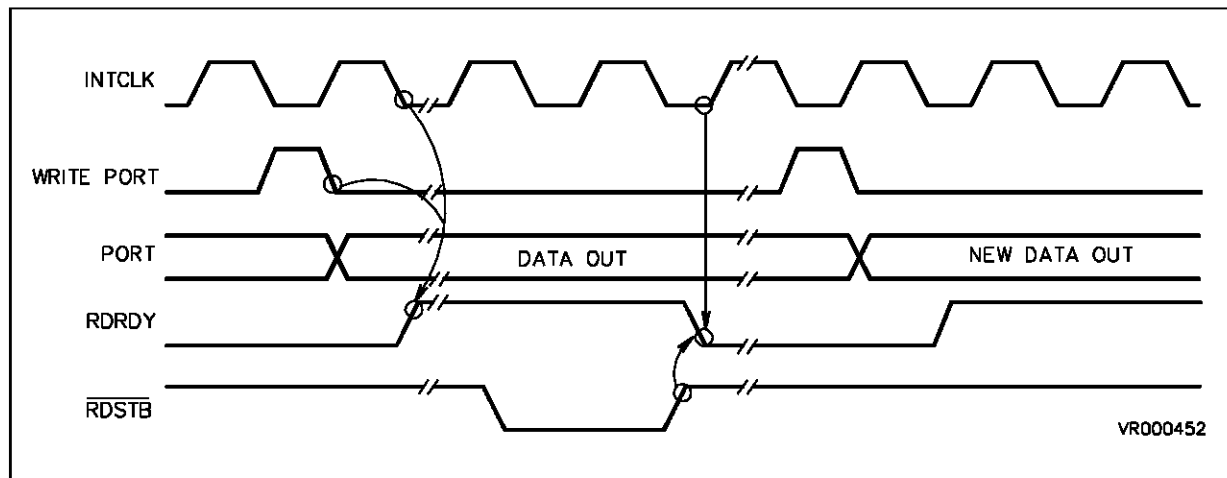

Figure 10-7. Two Line Output Handshake Timing



HANDSHAKE MODES (Continued)

One Line Output Handshake

Figure 10-9 illustrates the timing associated with the One Line (RDRDY) Output Handshake Mode Figure 10-8.

When this mode is selected RDRDY is reset to indicate that no significant data is present on the Output and Bidirectional port pins. When the Output Slave Latches are written to, RDRDY is set to indicate that data is ready for the peripheral device. In most systems the rising edge of RDRDY can be used as a latching signal in the peripheral device. No peripheral acknowledge is waited for. While ST9 is writing into the Output Slave Latches RDRDY goes low, RDRDY is set again when the new data is ready on the port pins.

Figure 10-8. One Line Output Handshake

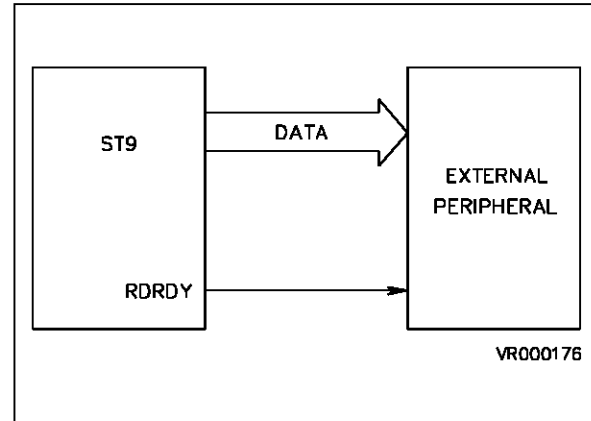
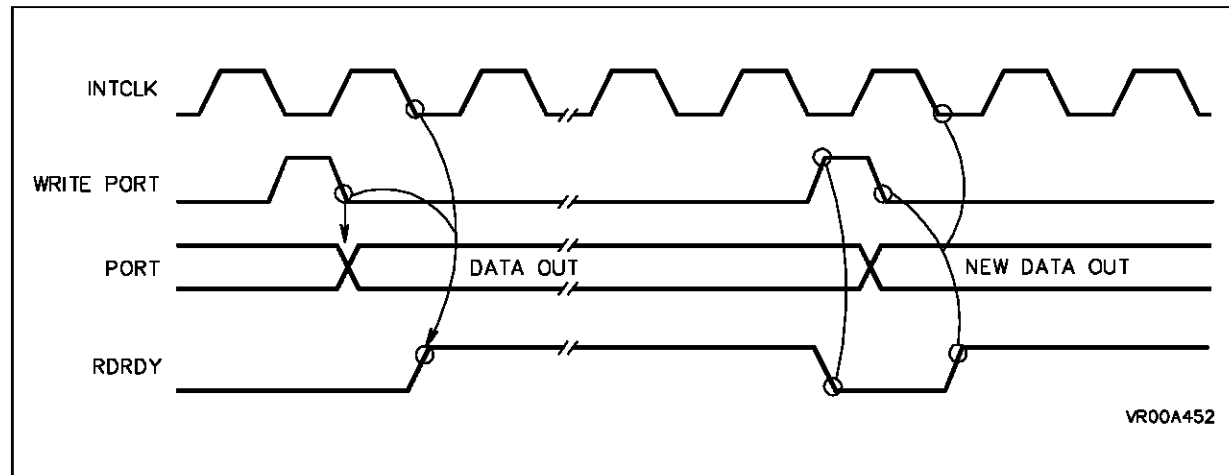

Figure 10-9. One Line Output Handshake Timing



ST9 - Handshake (ST902x)

HANDSHAKE MODES (Continued)

10.2.3 Bidirectional Handshake

A Bidirectional Handshake Mode is available to synchronise bidirectional transitions on Port bits programmed as Bidirectional. When this mode is selected, the Output Buffer configuration of Bidirectional port pins programmed as Weak Pull-up become Push-pull. Open-drain configuration is not modified. I/O bits set to Input, Output or Alternate Function Output are not affected.

Figure 10-11 illustrates the timing associated with the Bidirectional Handshake Mode. This mode is a combination of Two Lines Output Mode and Two Lines Input Mode using all four handshake lines, two for output (\overline{RDRDY} , \overline{RDSTB}) and two for input control (\overline{WRRDY} , \overline{WRSTB}). In the timing INTCLK is the ST9 internal not stretched clock, WRITE PORT is the signal that transfers data from the Internal Data Bus into the port Output Master Latches and READ PORT is the signal that transfers data from the Input Latches onto the Data Bus. When Bidirectional Handshake mode is selected the Output Buffers of the Bidirectional port pins are forced tristate, \overline{WRRDY} is set to indicate that data can be loaded into the Input Latches and \overline{RDRDY} is reset to indicate that no significant data is present in the Output Slave Latches.

Input Transitions. Data present on the pins is sampled when the peripheral forces a low level on \overline{WRSTB} . When a rising edge on \overline{WRSTB} occurs, \overline{WRRDY} goes low signifying that the Input Latches

are full and further loading must be inhibited until the ST9 reads the port. When the port register is read, \overline{WRRDY} is set. Both low and high levels on \overline{WRSTB} must last at least one ST9 INTCLK cycle.

The User is suggested to program the External interrupt Channel associated with the \overline{WRSTB} line to generate an interrupt request when a rising edge occurs. The ST9 can thus, in the course of its interrupt service routine, read the data furnished by the peripheral as soon as it is available.

Figure 10-10. Four Line Bidirectional

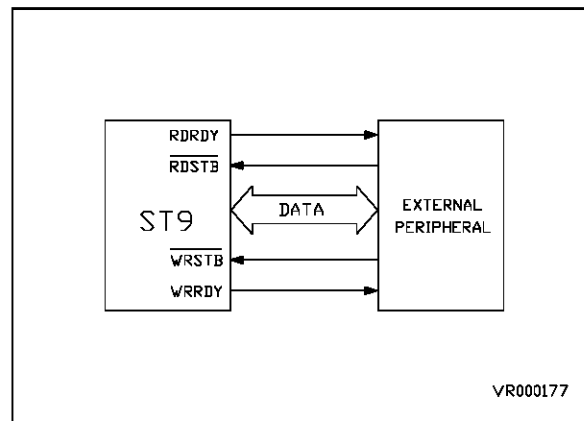
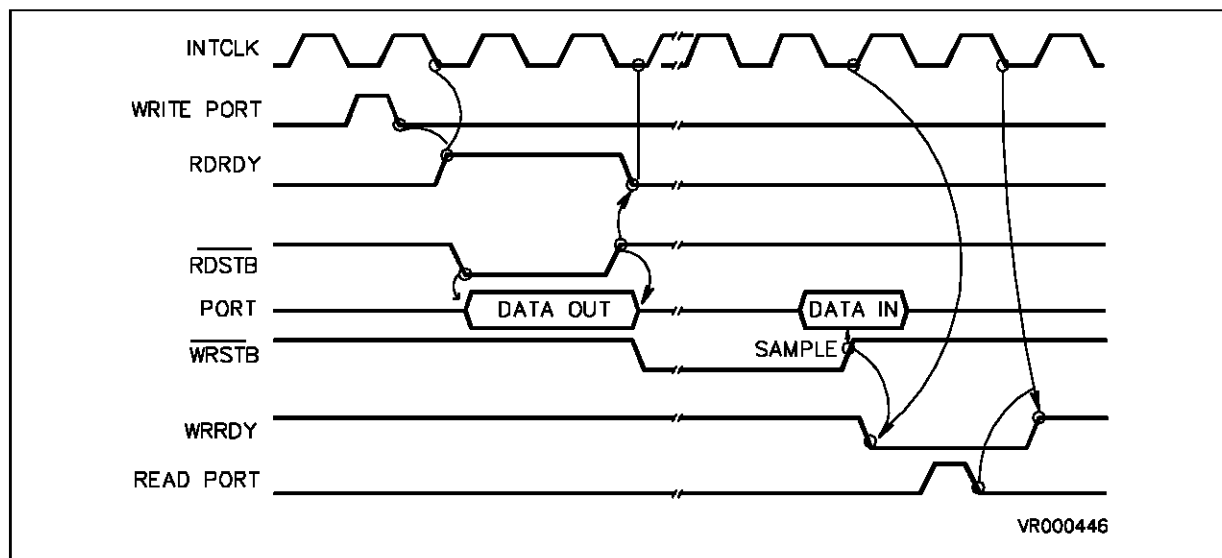

Figure 10-11. Bidirectional Handshake Timing



HANDSHAKE MODES (Continued)

Output Transitions. When the Output Slave Latches are written to, RDRDY is set to indicate that data is ready for the peripheral device. When \overline{RDSTB} goes low, data is allowed out onto the port pins. When a rising edge is received on \overline{RDSTB} , indicating that the peripheral has taken the data, the Output Buffers are forced tristate and \overline{RDRDY} goes low. Both low and high level on \overline{RDSTB} must last at least one INTCLK cycle.

The User is suggested to program the External Interrupt Channel associated to the \overline{RDSTB} line to generate an interrupt request when a rising edge occurs; The ST9 can thus, in the course of its interrupt service routine, write new data into the Output Slave Latches as soon as the previous data is taken by the peripheral.

10.2.4 Application example: Mapping an ST9 onto the memory bus of another ST9

Figure 10-12 shows a possible application of the bidirectional handshake protocol, used to connect an ST9 as a slave of another (master) ST9.

PX of the slave ST9 is connected to the Address/Data Memory Bus of the master ST9. A decoder enables, with a low level, the generation of \overline{RDSTB} or \overline{WRSTB} when \overline{DS} is low and the master is reading from, or writing to, the memory.

To synchronize data transfers with the slave, the master ST9 uses RDRDY and WRRDY as External Interrupt Sources, programmed to generate an interrupt request when a rising edge occurs. The slave ST9 interrupts the master raising RDRDY when new data is ready in the port Output Slave Latches and raising WRRDY when the Input Latches can be filled with new data. According to the interrupt request received, the master ST9 can read the ready data from the slave (RDRDY interrupt routine) or write other data into the slave (WRRDY interrupt routine).

Figure 10-12. Bidirectional Application Example

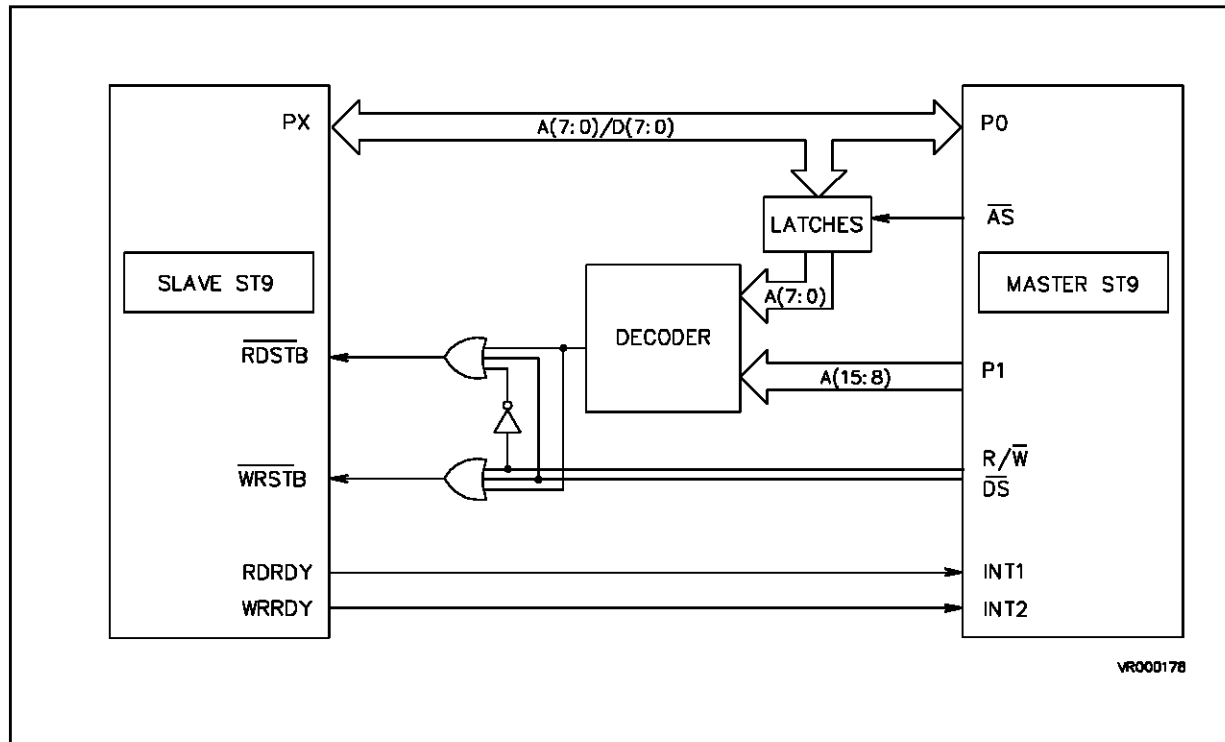

10.3 PROGRAMMABLE DMA MODES

The Handshake Module supports DMA operations controlled by either the CAPT0 or COMP0 DMA Channel of a Multifunction Timer. The User enables this function writing a "0" in the DEN bit in the HDCTL register and selects the DMA Channel by writing the DCH bit: "0" for CAPT0, "1" for COMP0.

When the CAPT0 Channel is chosen, the DD bit selects the Data Direction: "0" to move data from Data/Program Memory or Register File to the port (DMA Output), "1" to perform the opposite transfer (DMA Input). Signal CA_SYNCHR is sent by the Timer to the Handshake/DMA Controller for writing the port Output Master Latches or reading the Input latches (depending on DD), during the DMA operations when a capture occurs on the Timer.

If the Handshake section of the module is enabled, the data transfer from the Output Master Latches into the Output Slave Latches (Output Strobe, for pins programmed as Output or Bidirectional) or from the Pins into the Input Latches (Input Strobe, for pins programmed as Input or Bidirectional) is controlled by the logic supporting the chosen Handshake protocol.

If no Handshake is programmed the User can choose how to drive the Output or Input Strobe by writing the DST bit: a "0" leaves the Strobes under the normal port control, according to the chosen port bit configuration, a "1" selects the On Chip Event generated by the Timer as the Output or Input Strobe.

When the COMP0 Channel is selected, DMA output transfers are only allowed independent of DD, and CO_SYNCHR is used for output Master Latch. If Handshake is disabled, DST selects how to control the Output Strobe. If enabled, the Handshake controls the Output Strobe.

10.3.1 DMA Transfers Driven By Timer CAPT0 Channel With Handshake

The following descriptions are made assuming that DMA transfers are driven by Multifunction Timer 0. The following table shows the DMA Port capabilities of the ST9 family:

MultiFunction Timer	Handshake Port
MFT0	5

10.3.2 DMA Input transfers with two line input handshake

When

- Two Lines Input Handshake mode is selected (HS7="1", HS6="0", HS5="1")
- the port is enabled to support DMA input transfers driven by the Timer CAPT0 DMA Channel (DEN="0", DD="1", DCH="0")
- the Handshake \overline{WRSTB} line is connected off-chip to the Timer TOINA line
- TOINA DMA requests are enabled on rising edges
- \overline{WRSTB} interrupt requests are disabled, data transfers on port pins programmed as Input (or Bidirectional) can be synchronized using the Handshake \overline{WRSTB} line as DMA Request and the WRRDY line as DMA Acknowledge.

WRRDY is set to indicate that data can be loaded into the Input Latches of the Input (or Bidirectional) port pins. Data present on the port pins is sampled when the peripheral forces a low level on \overline{WRSTB} . When a rising edge on \overline{WRSTB} (TOINA) occurs WRRDY goes low, signifying that the Input Latches are full and further loading must be inhibited until the ST9 reads the port, and a DMA request is issued. When the port register is read, during the DMA transfer, WRRDY is set.

Figure 10-13. DMA with 2 Line Input Handshake Mode

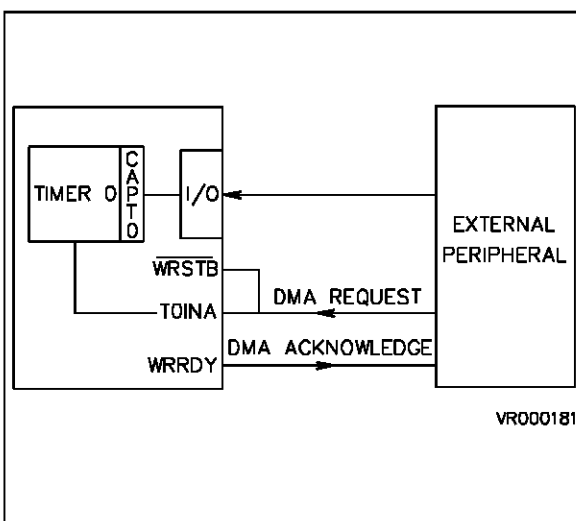

PROGRAMMABLE DMA MODES (Continued)

10.3.3 DMA output transfers with two lines output handshake

When

- Two Lines Output Handshake is selected (HS7="1", HS6="1", HS5="0")
- the port is enabled to support DMA output transfers driven by the Timer CAPT0 DMA Channel (DEN="0", DD="0", DCH="0")
- the Handshake \overline{RDSTB} line is connected off-chip to the Timer T0INA line
- T0INA DMA requests are enabled on rising edges
- \overline{RDSTB} interrupt requests are disabled

data transfers on port pins programmed as Output (or Bidirectional) can be synchronized when using the Handshake \overline{RDSTB} and RDRDY lines as DMA Request and DMA Acknowledge.

When Two Lines Output Handshake is selected, RDRDY is reset to indicate that no significant data is present on the Output and Bidirectional port pins. When the Output Slave Latches are written, RDRDY is set to indicate that data is ready for the peripheral device. The first data value, whose usual meaning is that ST9 is ready to provide the following data by DMA transfers, is normally written by the DMA initialization routine.

When a rising edge is received on \overline{RDSTB} (T0INA), indicating that the peripheral has taken the data, RDRDY is reset and a DMA request is issued to get the next data. When the ST9 Output Slave Latches are written, during the DMA transfer, RDRDY is set again. If the User wants to get

data from ST9 as soon as \overline{RDSTB} goes low, external latches clocked by \overline{RDSTB} can be added to create a pipeline stage, that is at each \overline{RDSTB} low pulse on the falling edge the peripheral gets data transferred into the port by the previous DMA transfer and on the rising edge a DMA request is issued to get the next data.

10.3.4 DMA input transfers with one line input handshake

When

- One Line Input Handshake is selected (HS7="0", HS6="0", HS5="1")
- the port is enabled to support DMA input operations driven by the Timer CAPT0 DMA Channel (DEN="0", DD="1", DCH="0")
- the Timer T0INA DMA requests are enabled on rising (or falling) edges data transfers on port pins programmed as Input (or Bidirectional) can be synchronized by using the Timer T0INA line as DMA Request, and the Handshake WRRDY line as DMA Acknowledge.

When One Line Input Handshake is selected WRRDY is set to indicate that data can be loaded into the Input Latches of the Input and Bidirectional port pins. Data present on the port pins is continuously sampled. While ST9 is reading the port, during the DMA transfer requested by a rising (or falling) edge on the Timer T0INA line, WRRDY goes low. If data is strobed into the port only when WRRDY is high, the forced low state of WRRDY will prevent Input Latches data from changing while ST9 is reading the port. When ST9 reading cycle finishes, WRRDY is set.

Figure 10-14. DMA output transfers with 2 lines output handshake

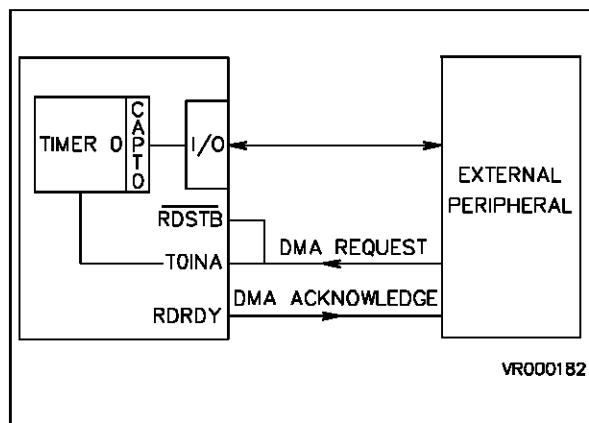
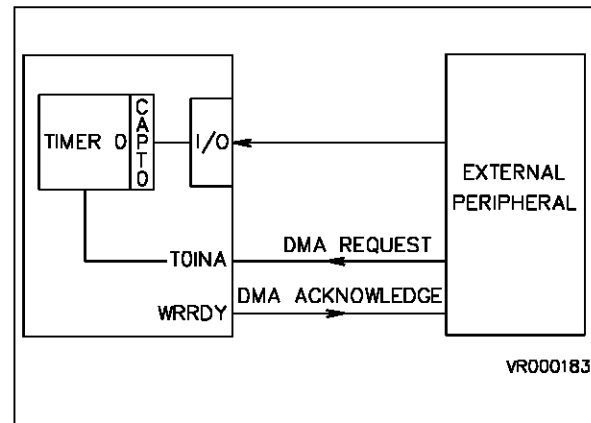

Figure 10-15. DMA input transfers with one line input handshake



ST9 - Handshake (ST902x)

PROGRAMMABLE DMA MODES (Continued)

10.3.5 DMA output transfers with one line output handshake

When

- One Line Output Handshake is selected (HS7="0", HS6="1", HS5="0")
- the port is enabled to support DMA output transfers driven by the Timer CAPT0 DMA Channel (DEN="0", DD="0", DCH="0")
- the Timer T0INA DMA requests are enabled on rising (or falling) edges

data transfers on port pins programmed as Output or Bidirectional can be synchronized using the Timer T0INA line as DMA Request, and the Handshake RDRDY line as DMA Acknowledge. RDRDY is reset to indicate that no significant data is present on the Output (or Bidirectional) port pins. When the ST9 Output Slave Latches are written, RDRDY is set to indicate that data are ready for the peripheral device. The first data, whose usual meaning is that the ST9 is ready to provide the following data by DMA transfers, is normally written by the DMA initialization routine.

When a rising (or falling) edge is received on T0INA, a DMA request is issued to get the next data. While ST9 is writing into the Output Slave Latches, during the DMA transfer, RDRDY goes low. RDRDY is set again when the new data is ready on the port pins.

Figure 10-16. DMA output transfers with one line output handshake

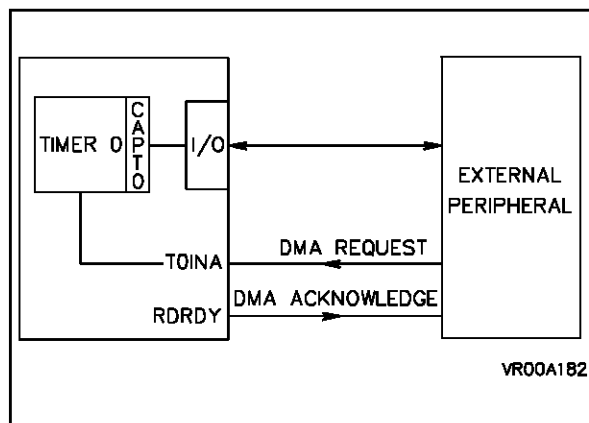

10.3.6 DMA input/output transfers with bidirectional handshake

When

- Bidirectional Handshake is selected (HS7="X", HS6="0", HS5="0")
- the port is enabled to support DMA transfers driven by the Timer CAPT0 DMA Channel (DEN="0", DCH="0")
- the Handshake \overline{WRSTB} and \overline{RDSTB} lines are ANDed and connected off-chip to the Timer T0INA line
- T0INA DMA requests are enabled on rising edges
- \overline{WRSTB} and \overline{RDSTB} interrupt requests are disabled

data transfers on port pins programmed as Bidirectional can be synchronized using the Handshake \overline{WRSTB} and \overline{RDRDY} lines as DMA Request and DMA Acknowledge for DMA Input transfers (DD="1") and the Handshake \overline{RDSTB} and \overline{RDRDY} lines as DMA Request and DMA Acknowledge for DMA Output transfers (DD="0").

DMA Input Transfers. When Bidirectional Handshake is selected \overline{RDRDY} is set to indicate that data can be loaded into the Input Latches of the Bidirectional port pins. Data present on the pins is sampled when the peripheral forces a low level on \overline{WRSTB} . When a rising edge on \overline{WRSTB} (T0INA) occurs \overline{RDRDY} goes low, signifying that the Input Latches are full and further loading must be inhibited until the ST9 reads the port, and a DMA request is issued. When the port register is read, during the DMA transfer, \overline{RDRDY} is set.

Figure 10-17. DMA input/output transfers with bidirectional handshake

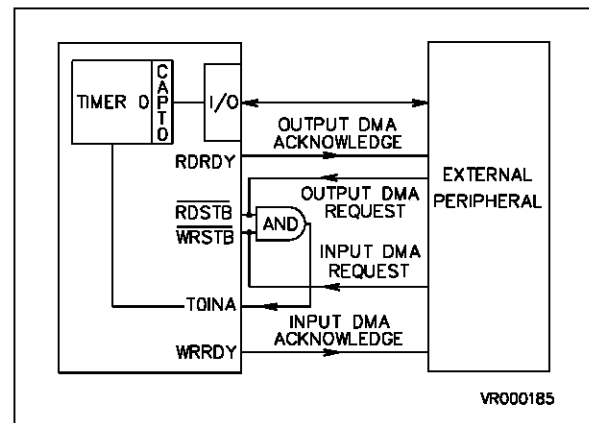

PROGRAMMABLE DMA MODES (Continued)

DMA Output Transfers. When Bidirectional Handshake is selected, RDRDY is reset to indicate that no significant data is present on the Bidirectional port pins. When the Output Slave Latches are written, RDRDY is set to indicate that data is ready for the peripheral device. The first data, whose usual meaning is that ST9 is ready to provide the following data by DMA transfers, is normally written by the DMA initialization routine.

When \overline{RDSTB} goes low data is allowed onto the port pins. When a rising edge is received on \overline{RDSTB} (TOINA), indicating that the peripheral has taken the data, the Output Buffers are forced tristate, RDRDY is reset and a DMA request is issued to get the next data. When the Output Slave Latches are written during the DMA transfer, RDRDY is set again.

In the output data flow there is one pipeline stage, that is at each \overline{RDSTB} low pulse on the falling edge the peripheral gets data transferred into the port by the previous DMA transfer and on the rising edge issues a DMA request to get the next data.

Example. As the direction of DMA transfers is controlled by software, the User must define a protocol to control the sequence of input/output data transfers.

The initialization routine defines the direction (DD) of the first DMA transfer and the address and size of the data buffer (Pointer and Counter associated to the DMA Channel). In the interrupt routine called when the DMA Transaction Counter = 0, the User

must define the new address and size of the data buffer and can change (according to the chosen protocol) the direction of next DMA operations.

Figure 10-18 shows how the application example of Figure 10-17 (an ST9 connected as a slave of another ST9) is modified when data transfer from/to the slave ST9 is performed by DMA transfers.

10.3.7 DMA Transfers Driven By Timer

DMA output transfers with one line output handshake

when

- One Line Output Handshake is selected (HS7="0", HS6="1", HS5="0")
- the port is enabled to support DMA output transfers driven by the Timer COMP0 DMA Channel (DEN="0", DCH="1")

data transferred by DMA transfers on port pins programmed as Output or Bidirectional can be strobed using the Handshake RDRDY line.

When One Line Output Handshake is selected RDRDY is reset to indicate that no significant data is present on the Output and Bidirectional port pins. When the Output Slave Latches are written RDRDY is set. The rising edge of RDRDY can be used as a latching signal. At every DMA transfer triggered by the COMP0 event new data is written into the port. While data is changing on the Output Slave Latches, RDRDY goes low. RDRDY is set again when the new data is ready on the port pins.

Figure 10-18. Bidirectional Application Example With DMA Transfer

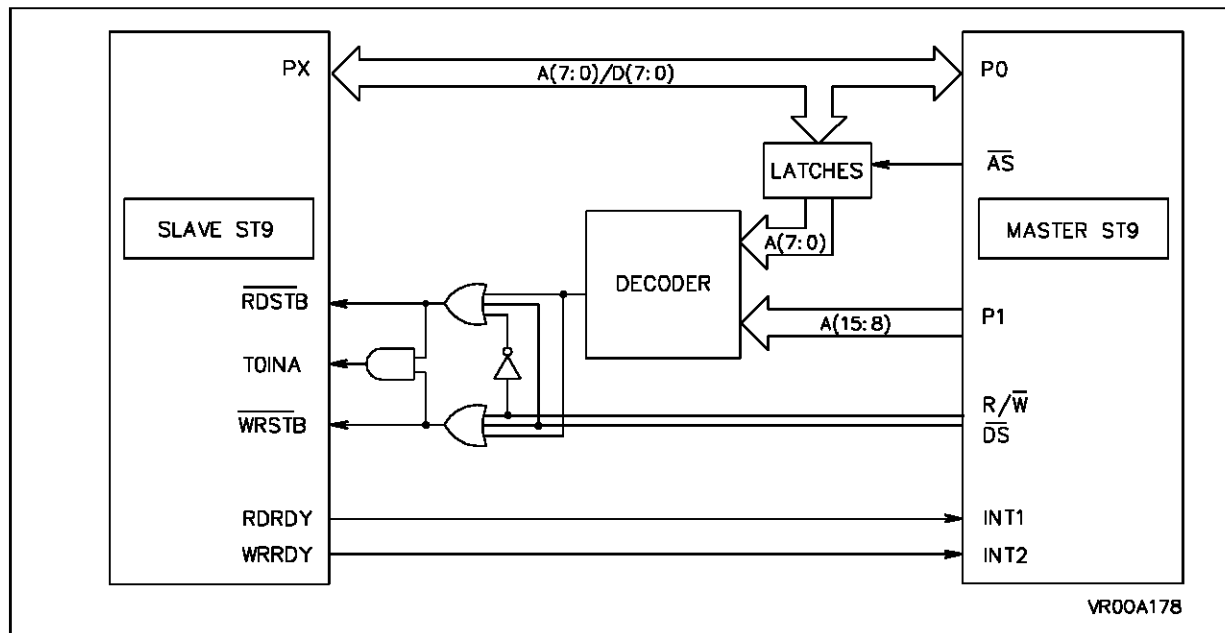

ST9 - Handshake (ST902x)

10.4 HANDSHAKE/DMA CONTROL REGISTERS

To program the Handshake and DMA modes, the User has to write the Handshake/DMA Control register (HDCTL) according to the table shown in page 84. The different handshake protocols and the Port behaviour during DMA operations are explain in the previous paragraphs.

HDCTL5 Read/Write
Handshake/DMA Control Register

Reset Value: 1111 1111 (0FFh)

7								0
HS7	HS6	HS5	DEN	DD	DST	DCH	1	

b7-b5 = **HS7, HS6, HS5**: *Handshake Mode Selection*. These bits allow selection of the Handshake direction and the number of lines used in the handshake as shown in the following table.

b4 = **DEN**: *DMA Enable*. This bit (when reset) enables the DMA function with handshake through I/O Port 5. DMA is disabled when this bit = "1".

b3 = **DD**: *DMA Data Direction*. The direction of the DMA transfers through I/O Port 5 is set by this bit. A "1" sets DMA Input and a "0" sets DMA Output.

b2 = **DST**: *DMA Strobe*. This bit, when set, enables the use of the Multifunction Timer 0 On-Chip Event to trigger the DMA transaction.

b1 = **DCH**: *DMA Channel* When DST is set, allowing the DMA transactions to be triggered by Multifunction Timer 0, DCH selects the MFT source, a "1" selects the COMP0 source, a "0" selects the CAPT0 source.

b0 = **D0**. This bit is fixed by hardware to a high level.

Table 10-1. Module Configuration Table

Handshake Modes		HS7	HS6	HS5
Disabled		X	1	1
Output	(2 lines)	1	1	0
Output	(1 line)	0	1	0
Input	(2 lines)	1	0	1
Input	(1 line)	0	0	1
Bidirectional	(2 lines)	X	0	0

CONTROL REGISTERS (Continued)

Figure 10-19. Handshake/DMA Control Registers

Applicable to ST902x

GROUP E			GROUP F			
			PAGE 2		PAGE 3	
			FFh	Reserved		R255
			FEh	P3C2		R254
			FDh	P3C1		R253
			FCh	P3C0		R252
			FBh	Reserved		R251
			FAh	P2C2		R250
			F9h	P2C1		R249
			F8h	P2C0		R248
			F7h	Reserved		R247
			F6h	P1C2		R246
E5h	P5DR	R229	F5h	P1C1		R245
E4h	Reserved	R228	F4h	P1C0		R244
E3h	P3DR	R227	F3h	Reserved		R243
E2h	P2DR	R226	F2h	P0C2		R242
E1h	P1DR	R225	F1h	P0C1		R241
E0h	P0DR	R224	F0h	P0C0		R240
					HDCTL5	R247
					P5C2	R246
					P5C1	R245
					P5C0	R244
					Reserved	R243
					Reserved	R242
					Reserved	R241
					Reserved	R240

ST9 - Handshake (ST902x)

Notes :

11 SERIAL PERIPHERAL INTERFACE

11.1 INTRODUCTION

The Serial Peripheral Interface (SPI) is integrated into the Core module of the ST9 and provides a general purpose shift register based peripheral allowing several external peripherals to be linked through an SPI protocol bus. In addition, special modes allow reduced software overhead with I²C-bus and IM-bus Communication standards.

The SPI uses 3 lines comprising Serial Data In (SDI) and Alternate Function outputs Serial Data Out (SDO) and Synchronous Serial Clock (SCK). Additional I/O pins may act as device selects or IM-bus address ident signals.

Its Main Features are:

- Full duplex 3-wire synchronous transfer
- Master operation only
- 1.5MHz max bit transfer frequency (INTCLK = 12MHz, 93KHz for S-bus/I²C-bus)
- 4 Programmable bit rates
- Programmable clock polarity and phase
- Busy Flag
- End of transmission interrupt
- Additional hardware to facilitate more complex protocols

Figure 11-1. Block Diagram

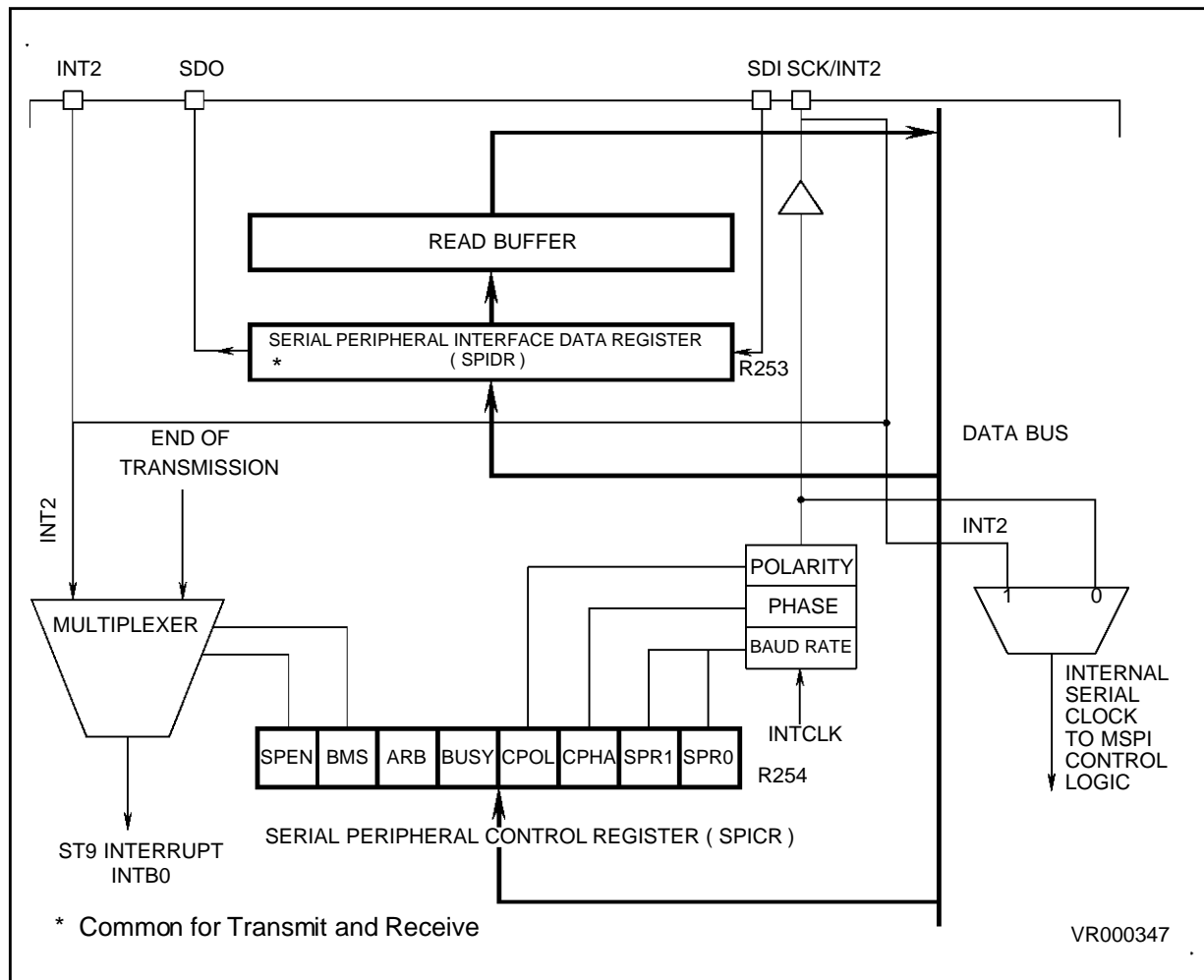

11.2 FUNCTIONAL DESCRIPTION

The SPI, when enabled, receives input data from the ST9 Core internal data bus into SPIDR, and originates the Serial Clock (SCK) based upon dividing of the internal processor clock (INTCLK). The data is parallel loaded into the 8 bit shift register (from the internal bus) during a write cycle and then shifted out serially through the SDO pin (Most Significant bit first) to the slave device, which responds by sending its data to the master device via the SDI pin. This implies full duplex transmission with data-out and data-in both synchronized with the same clock signal. Thus the transmitted byte is replaced by the byte received, eliminating the need to have separate "Tx empty" and "Rx full" status bits.

When the shift register is loaded, data is parallel transferred to the read buffer and data becomes available for the ST9 during a following read cycle.

The SPI requires three pins on an I/O port:

SCK	Serial Clock signal
SDO	Serial Data Out
SDI	Serial Data In

An additional output bit of an I/O port may be used to perform the slave chip select signal.

Figure 11-2. A Typical SPI Network

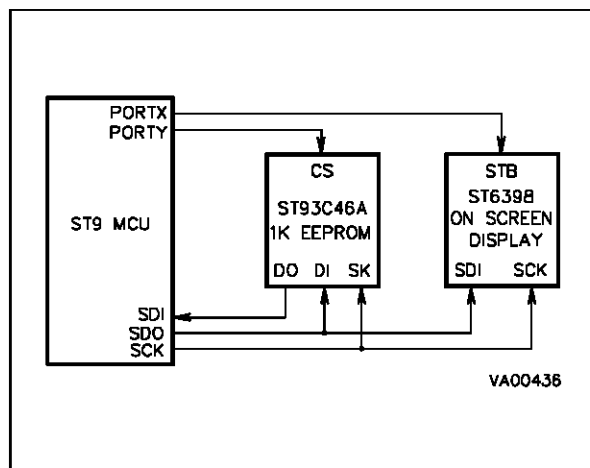

11.2.1 Input Signal Description

Serial Data In (SDI)

Data is transferred serially from a slave to a master on this line, most significant bit first. In an S-BUS/I²C-bus configuration, SDI line senses the value forced on the data line (by SDO or by another peripheral connected to the S-bus/I²C-bus environment).

11.2.2 Output Signal Description

Serial Data Out (SDO)

The SDO pin is configured as an output for the master device. This is obtained by programming the corresponding I/O pin as an output alternate function. Data is transferred serially from a master to a slave on SDO, most significant bit first. This pin is forced to the high impedance state when the SPI is disabled and is set to "1" when arbitration is lost (during an S-bus/I²C-bus protocol transmission). The master device always allows data to be applied on the SDO line one half cycle before the clock edge in order to latch the data for the slave device.

Master Serial Clock (SCK)

The master device uses SCK to latch the incoming data on the SDI line. This pin is forced to a high impedance state when SPI is disabled (SPEN, SPICR.7 = "0"), in order to avoid clock contention from different masters in a multi-master system.

The master device generates SCK from INTCLK. SCK is used to synchronize the transfer of data both in and out of the device through its SDI and SDO pins. The SCK type and its relationship to data are controlled by the CPOL and CPHA bits in the Serial Peripheral Control Register.

This input is provided with a digital filter which cleans spikes lasting less than one INTCLK period.

Two bits (SPR1 and SPR0) in the Serial Peripheral Control Register, SPICR (R254) select the clock rate. Four frequencies can be selected, two in a high frequency range (mostly used with the SPI protocol) and two in a medium frequency range (mostly used for more complex protocols).

11.3 INTERRUPT STRUCTURE

SPI peripheral is associated with external interrupt channel B0 (pin INT2). Multiplexing between the external pin and SPI internal source is controlled by the SPEN and BMS bits according to the following table.

The two possible SPI interrupt sources are: End of transmission (after each byte) and S-bus/I²C-bus start condition. Care should be taken when toggling SPEN or/and BMS bits from (0,0) status, this should be done by masking the interrupt channel B0 (reset of EIMR.IMB0, bit 2 of External Interrupt Mask Register). Furthermore it is necessary to clear possible spurious requests on the corresponding channel by resetting the interrupt pending bit EIPR.IPB0 (bit 2 of External Interrupts Pending Register).

The INT2 input Function is always mapped together with the SCK input Function to allow start/stop bit detection when using S-bus/I²C-bus protocols.

A delay instruction (e.g. a NOP instruction) should be inserted between the SPEN toggle instruction and the interrupt pending bit reset instruction.

Table 11-1. Interrupt Configuration

SPEN	BMS	Interrupt Source
0	0	External channel INT2
0	1	S-bus/I ² C bus start or stop condition
1	X	End of one byte transmission

Figure 11-3. SPI I/O Pins

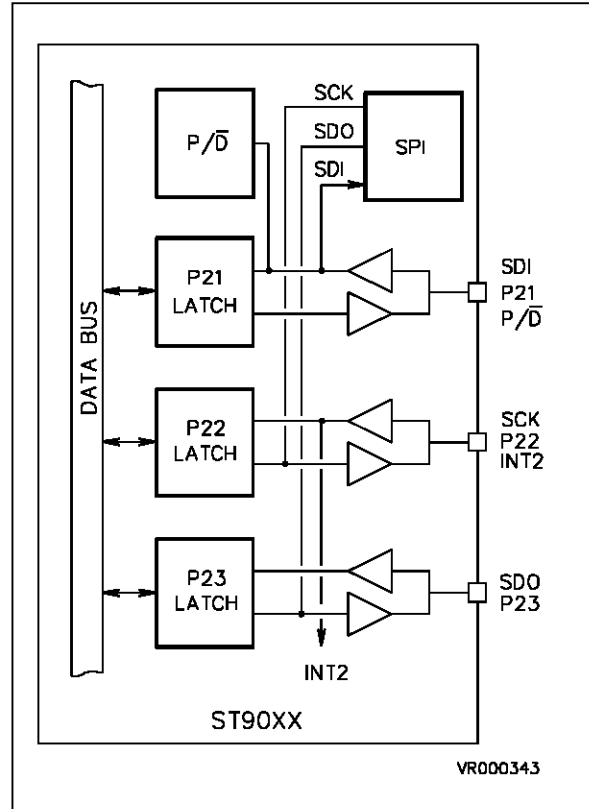

ST9 - Serial Peripheral Interface (ST902x)

11.4 SPI REGISTERS

SPI uses two registers mapped on page 0 of the register file:

SPIDR R253 (FDh) Page 0 Read/Write
SPI Data Register

Reset Value: 0000 0000b (00h)

7							0
D7	D6	D5	D4	D3	D2	D1	D0

b7-b0 = **D0-D7**: *SPI Data Bits*. This register contains the data transmitted and received by the SPI. Data is transmitted b7 first, and receives incoming data into b0. Transmission is started by writing to this register.

SPICR R254 (FEh) Page 0 Read/Write
SPI Control Register

Reset Value: 0000 0000b (00h)

7							0
SPEN	BMS	ARB	BUSY	CPOL	CPHA	SPR1	SPR0

b7 = **SPEN**: *Serial Peripheral Enable*. When set, the two alternate functions SCK and SDO are enabled. When disabled, SCK and SDO are kept in high impedance. Furthermore, SPEN affects the selection of the source for interrupt channel B0. Transmission will start by simply writing the data into the SPIDR Register.

b6 = **BMS**: *S-bus/I²C-bus Mode Selector*. This bit should be set to "1" when the SPI is used in an S-bus/I²C-bus protocol. It enables S-bus/I²C-bus arbitration, clock synchronization and Start/ Stop detection.

When this bit is reset to "0", a reinitialisation of the SPI logic is performed allowing recovery procedures after a Rx/Tx failure. BMS (and SPEN) affects the selection of the source for interrupt channel B0.

b5 = **ARB**: *Arbitration flag bit*. This bit is set when the SPI, in S-bus/I²C-bus mode, loses arbitration, and is reset when an S-bus/I²C-bus stop condition is detected. ARB can be reset by software. When ARB is set automatically, the SDO pin is set to high value until a write instruction on SPIDR is performed.

b4 = **BUSY**: *SPI Busy Flag*. BUSY flag is set when a transmission is in process. This bit allows the user to monitor the SPI status by polling its value.

b3 = **CPOL**: *Transmission Clock Polarity*. CPOL controls the normal or steady state value of the clock when data is not being transferred.

As the SCK line is held in a high impedance state when the SPI is disabled (SPEN = "0"), the SCK pin must be connected to Vss or Vcc through a resistor according to the CPOL state. Polarity should be selected during the reset routine according to the value set into all peripherals and must not be changed during program execution.

b2 = **CPHA**: *Transmission Clock Phase*. CPHA controls the relationship between the data on the SDI and SDO pins and the clock produced at the SCK pin. CPHA bit selects the clock edge which captures data and allows it to change state. It has its greatest impact on the first bit transmitted (MSB) because it does (or does not) allow a clock transition before the first data capture edge.

Figure 11-5 shows the relationship between CPHA, CPOL and SCK, and indicates active clock edges and strobe times.

CPOL	CPHA	SCK on Figure 11-5
0	0	(a)
0	1	(b)
1	0	(c)
1	1	(d)

b1-b0 = **SPR1, SPR0**: *SPI Rate*. These two bits select one (out of four) baud rates to be used as SCK.

SPR1	SPR0	Clock Divider	SCK Frequency (INTCLK = 12MHz)
0	0	8	1500kHz (T = 0.67μs)
0	1	16	750kHz (T = 1.33μs)
1	0	128	93.75kHz (T = 10.66μs)
1	1	256	46.87kHz (T = 21.33μs)

11.5 WORKING with DIFFERENT PROTOCOLS

The SPI peripheral offers the following facilities to work with S-bus/I²C-bus and IM-bus protocols:

- Interrupt request on start/stop detection
- Hardware clock synchronisation
- Arbitration lost flag with an automatic set of data line

Note that the I/O bit associated to the SPI should be returned to a defined state as a normal I/O pin before changing the SPI protocol.

The following paragraphs provide information to manage these protocols.

11.5.1 I²C-bus Interface

I²C-bus is a two-wire bidirectional data-bus, the two lines being SDA (Serial DATA) and SCL (Serial CLock). Both are open drain lines to allow arbitration. As shown in figure 11-6, data is toggled with clock low and Start and Stop conditions are detected when a high to low (start) or a low to high (stop) transition on the SDA line occurs with the SCL line high.

Each transmission consists of nine clock pulses (SCL line). The first 8 pulses transmit the byte (msb first), the ninth is used by the receiver to acknowledge.

Figure 11-4. S-Bus/I²C-bus Peripheral Compatibility without S-Bus Chip Select

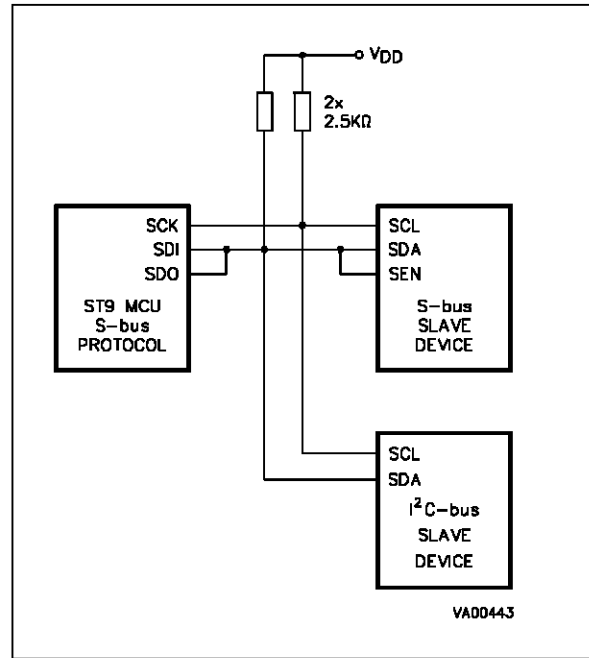
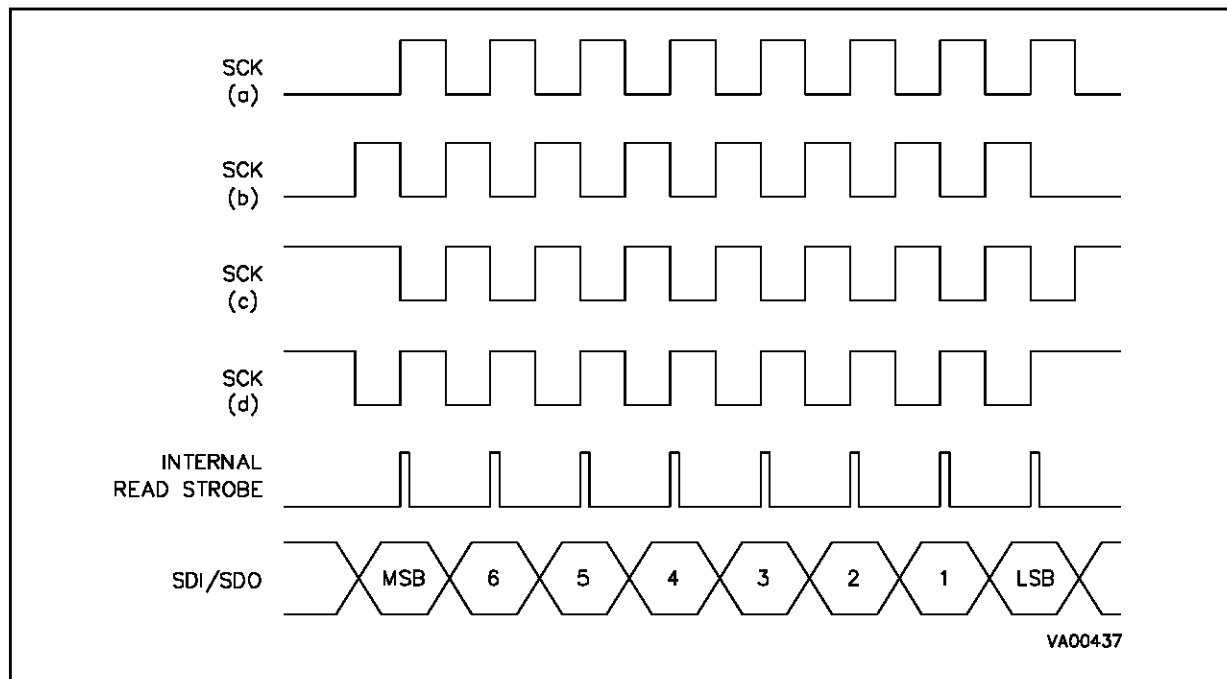

Figure 11-5. SPI Data and Clock Timing



ST9 - Serial Peripheral Interface (ST902x)

DIFFERENT PROTOCOLS (Continued)

Table 11-2. Typical I²C-bus Sequences

Phase	Software	Hardware	Notes
INITIALIZE	SPICR.CPOL, CPHA = 0, 0 SPICR.SPEN = 0 SPICR.BMS = 1 SCK pin set as AF output SDI pin set as input Set SDO port bit to 1	SCK, SDO IN HI-Z SCL, SDA = 1, 1	Set polarity and phase SPI disable START/STOP interrupt Enable
START	SDO pin set as output Open Drain Set SDO port bit to 0	SDA = 0, SCL = 1 interrupt request	START condition receiver START detection
TRANSMISSION	SPICR.SPEN = 1 SDO pin as Alternate Function output load data into SPIDR	SCL = 0 Start transmission interrupt request	Managed by interrupt routine load FFh when receiving end of transmission detection
ACKNOWLEDGE	SPICR.SPEN = 0 Poll SDA line Set SDA line SPICR.SPEN = 1	SCK, SDO in HI-Z SCL, SDA = 1 SCL = 0	SPI disable only if transmitting only if receiving only if transmitting
STOP	SDO pin set as output Open Drain SPICR.SPEN = 0 Set SDO port bit to 1	SDA = 1 interrupt request	STOP condition

Figure 11-6. SPI Data and Clock Timing

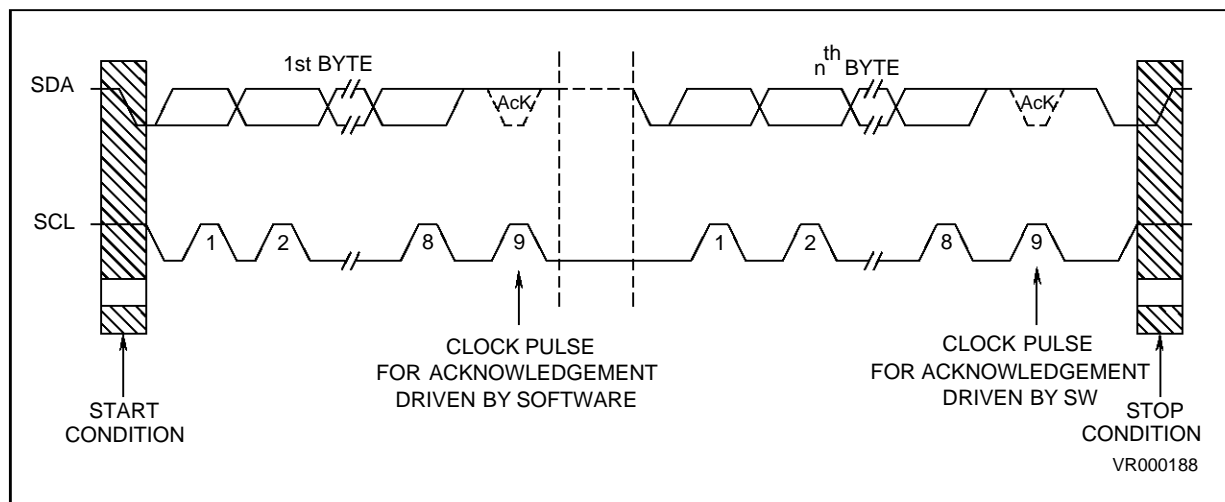

DIFFERENT PROTOCOLS (Continued)

The data on the SDA line is sampled with the low to high transition on the SCL line.

SPI Working With I²C-bus

To use the SPI with the I²C-bus protocol, the SCK line is used as SCL, the SDI and SDO lines, externally wired-OR'd, are used as SDA. All the output pins must be configured as open drain (see Figure 11-4).

Table 11-2 shows the typical I²C-bus sequence divided in 5 phases: initialize, start, transmission, acknowledge and stop.

Software and hardware will take care of each phase. A master to slave transmission can be managed as example according to the following table.

During the transmission phase, the following I²C-bus features are also supported by hardware.

Clock Synchronization

In a multimaster I²C-bus system, when more masters generate their own clock, synchronization is needed. The first master which releases the SCL line stops internal counting, restarting only when

the SCL line goes high (released by all the other masters). In this way, devices using different clock sources and different frequencies can be interfaced.

Arbitration Lost

When more masters are sending data on SDA line, the following mechanism is performed: if the transmitter sends a "1" and SDA line is forced low by another device the ARB flag (SPICR.5) is set and the SDO buffer is "switched off". (ARB is reset and SDO buffer is "switched on" when SPIDR is written to again). When BMS is set to "1" the peripheral clock is supplied through the INT2 line by the external clock line (SCL). Due to potential noise spikes (which must last longer than one INTCLK period to be detected), RX or TX may gain a clock pulse.

Referring to Figure 11-7, if ST9-1 detects a noise spike and gains a clock pulse, it will stop its transmission in advance and hold the clock line low causing ST9-2 to be frozen at the 7th bit. To exit and recover from this condition the BMS bit must be reset to "0", this will cause the reset of the SPI logic, aborting the current transmission. An End of Transmission interrupt is generated after this reset sequence.

Figure 11-7. SPI Arbitration

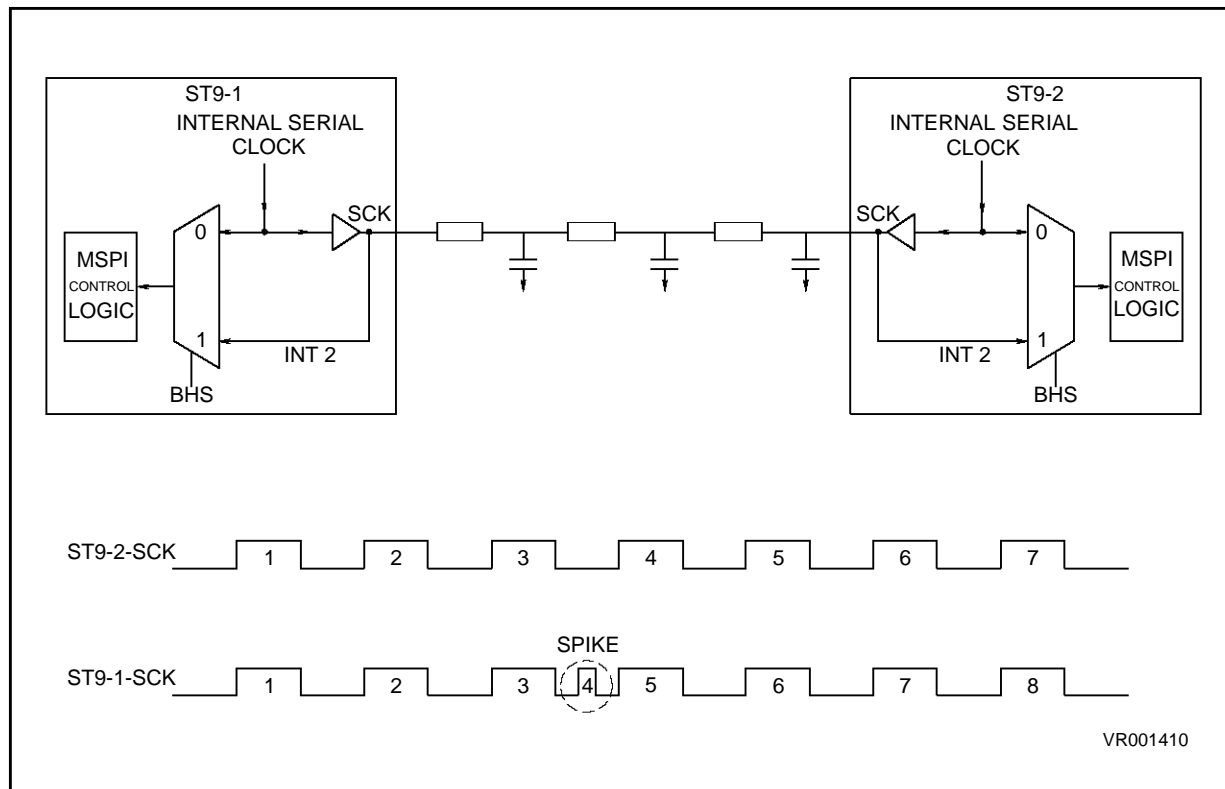

VR001410

ST9 - Serial Peripheral Interface (ST902x)

DIFFERENT PROTOCOLS (Continued)

11.5.2 S-Bus Interface

S-bus is a three-wire bidirectional data-bus, with functional features similar to I²C-bus. Differently from I²C-bus, the START/STOP conditions are given by encoding the information on 3 wires instead of 2, as shown in Figure 11-8. The additional line is referred as SEN.

SPI Working With S-bus

The S-bus protocol uses the same pin configuration as I²C-bus for generating the SCL and SDA lines. The additional SEN line is managed through a standard ST9 I/O port under software control (see Figure 11-9).

Figure 11-8. Mixed S-bus and I²C-bus system

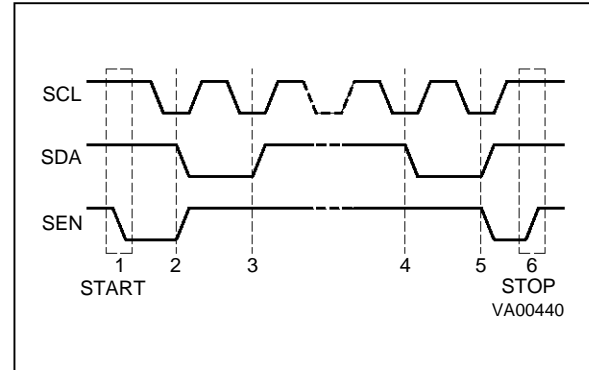

Figure 11-9. S-bus Configuration

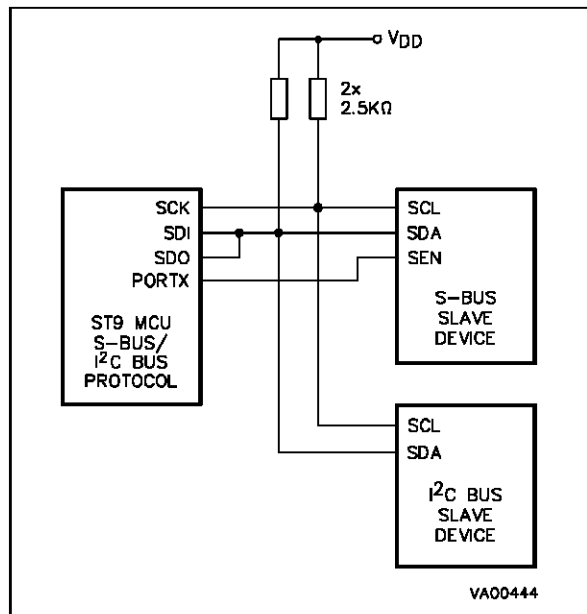
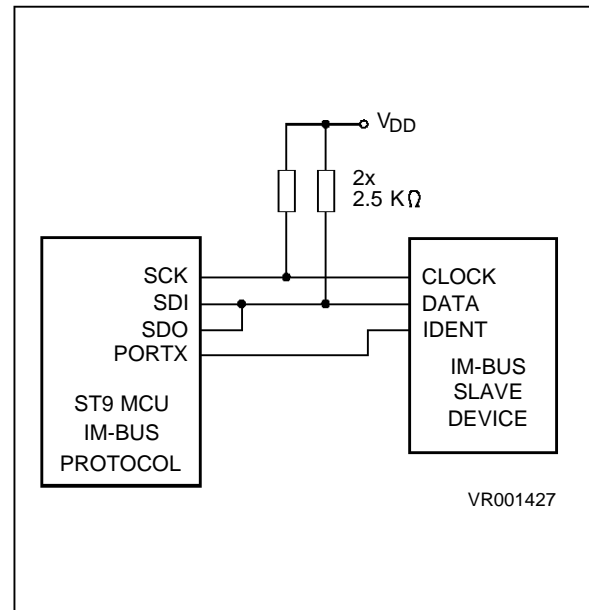

Figure 11-10. ST9 and InterMetal Peripheral



DIFFERENT PROTOCOLS (Continued)

11.5.3 IM-Bus Interface

The IM-bus has a bidirectional data line and a clock line, and in addition it requires an IDENT line that distinguishes an address from a data byte (Figure 11-11). Unlike the I²C-bus protocol, the IM-bus protocol sends the least significant bit first, this requires a software routine which reverses the bit order before sending, and after receiving a data byte. Figure 11-10 shows the connections for an IM-bus peripheral to an ST9 SPI. The SDO and SDI pins are connected to the bidirectional data pin of the peripheral device. The SDO alternate function is set in Open Drain (external 2.5KΩ pull-up resistors are required).

With this type of configuration, data is sent to the peripheral by writing the data byte to SPIDR. To receive data from the peripheral, the User should

write FFh into SPIDR in order to generate the shift clock pulses. As the SDO line is set to the Open Drain configuration, the incoming data bits that are set to one do not affect the SDO/SDI line status (which defaults to a high level due to the FFh in the transmit register), while incoming bits that are set to “0” pull the input line low.

In software it is necessary to initialise the ST9 SPI with CPOL and CPHA set to “1”, “1”. By using a general purpose I/O as the IDENT line and forcing it to a logical “0” when writing to SPIDR, an address is sent (or read). Then, by setting this bit to a logical “1” and writing to SPIDR, data is sent to the peripheral. When all the address and data pairs are sent it is necessary to drive the IDENT line low and high to create a short pulse. In this way the stop condition is generated.

Figure 11-11. IM bus Timing

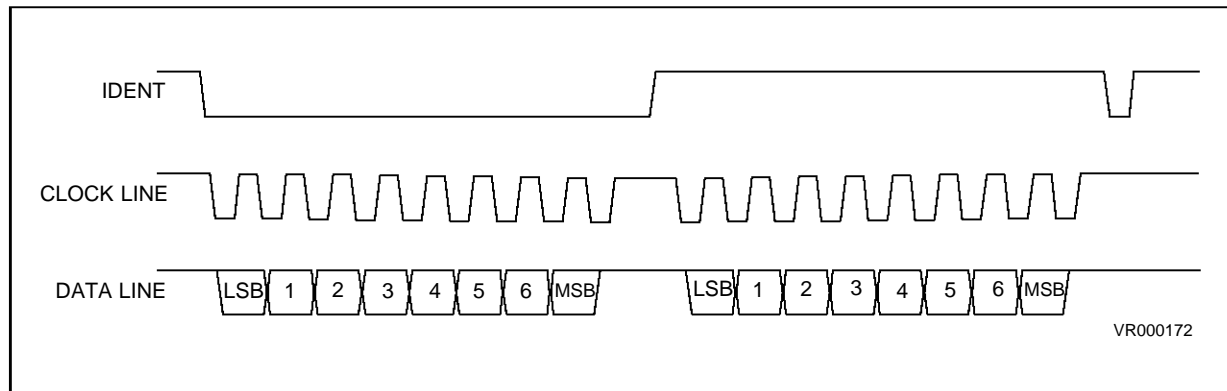

ST9 - Serial Peripheral Interface (ST902x)

Notes :

12 TIMER/WATCHDOG

12.1 INTRODUCTION

A programmable 16-bit down counter with an 8-bit prescaler is included in the ST9 Core. This Timer can be programmed to be used as a general purpose 16-bit Timer, with associated input and output pins for timing functions, or as a Watchdog Timer offering security against possible processor malfunctions due to hardware or software failures.

The Timer/Watchdog functions can use inputs from an external pin and an Alternate Function output of an I/O Port. The Input pin can be used in one of the four programmable input modes:

- event counter,
- gated external input mode,
- triggerable input mode,
- retriggerable input mode.

The output pin can be used to generate a square or a Pulse Width Modulated signal.

An interrupt generated by the unit (when running as a 16-bit Timer/counter and not as Watchdog) can be used as a Top Level Interrupt or as an interrupt source connected to channel A0 of the external interrupt structure (replacing the INT1 interrupt input).

The clock for the counter can be driven either by an external clock or an internal clock equal to INTCLK divided by 4.

When using an external 24MHz crystal (INTCLK = 12MHz), the End Of Count rate is:

5.59 sec. for Max. Count (Timer Const. = FFFFh, Prescaler Const. = FFh)

333 nsec. for Min. Count (Timer Const. = 0000h, Prescaler Const. = 00h)

Figure 12-1. Block Diagram

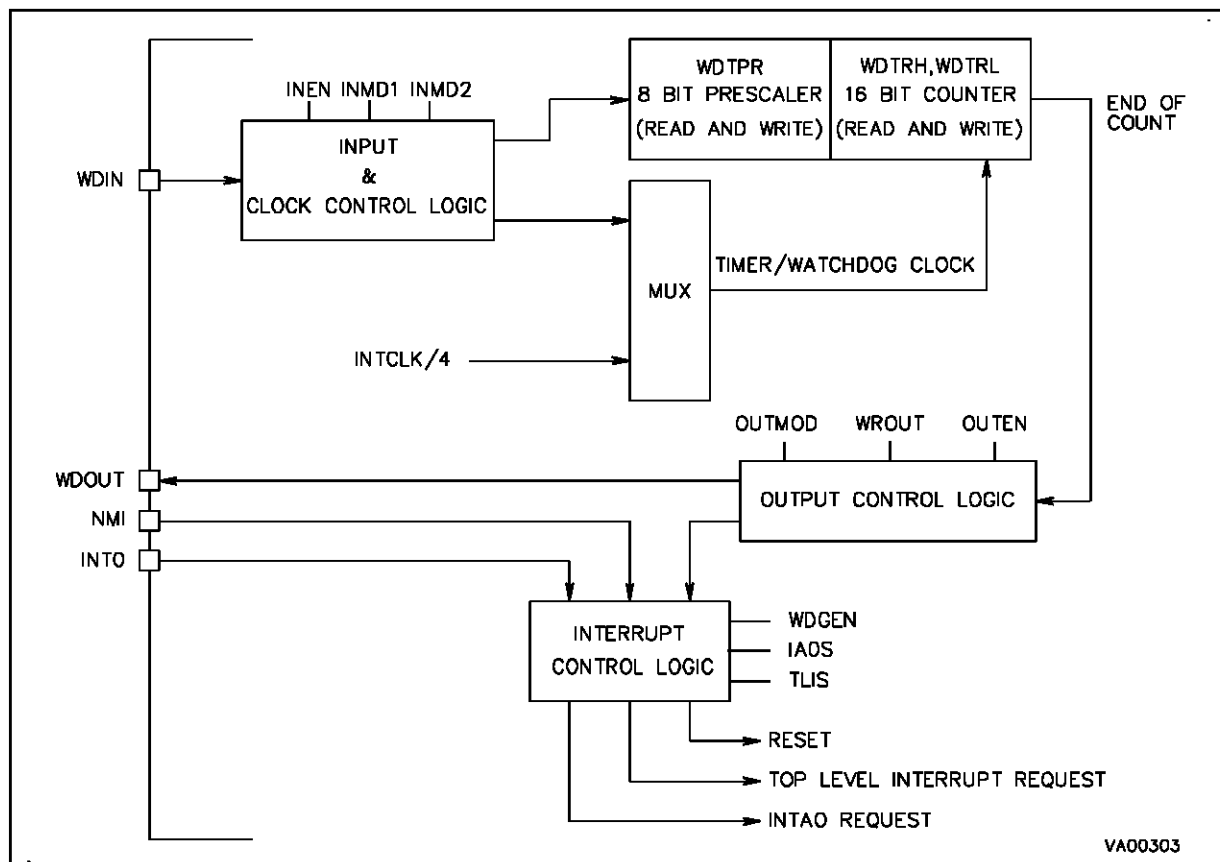

12.2 FUNCTIONAL DESCRIPTION

12.2.1 Timer/Counter Input Modes

Setting the Input Enable (INEN) bit enables the input mode which is selected via the INMD1 and INMD2 bits. When INEN is reset to zero, the input section is disabled and the values of INMD1 and INMD2 are don't-care.

Event Counter Mode

(INMD1 = "0", INMD2 = "0")

The Timer is driven by the signal applied to the input pin which acts as an external clock. The unit works therefore as an event counter. The event is a high to low transition of the input signal.

Spacing between trailing edges should be at least 350ns (i.e. the maximum Watchdog Timer input frequency is 2.9MHz with INTCLK = 12MHz).

Gated Input Mode

(INMD1 = "0", INMD2 = "1")

The Timer uses the Watchdog internal clock (INTCLK divided by 4) and starts and stops the Timer according to the input pin. When the status of the Input pin is High the Timer Watchdog count operation proceeds, and when Low, counting is stopped.

Retriggerable Input Mode

(INMD1 = "1", INMD2 = "1")

A Timer/Watchdog start is caused by:

- a set of the Start-Stop bit, or
- a High to Low (low trigger) transition on the input pin.

In order to stop the Timer, it is only necessary to reset the Start-Stop bit to zero.

Triggerable Input Mode

(INMD1 = "1", INMD2 = "0")

In this mode when the Timer is running (TIMER/WATCHDOG internal clock), a High to Low transition of the input pin causes the counting to start from the initial value. When the Timer is stopped (ST_SP bit equal to zero), a High to Low transition of the input pin has no effect.

12.2.2 Timer/Watchdog Output Modes

OUTPUT modes are selected using 2 bits of WDTCR (R251): OUTEN (Output Enable) and OUTMD (Output Mode).

When OUTMD = "0", the Timer outputs a signal with a frequency equal to half the End Of Count repetition rate. With INTCLK = 12MHz, this allows

generation of a square wave with a period ranging from 666ns to 11.18 seconds.

The value of the WROUT bit is transferred to the output pin at the End Of Count and the value is held until the next End of Count when OUTMD = "1". This allows the user to generate PWM signals, by modifying the status of WROUT between End of Count events, based on software counters decremented on the Timer/Watchdog interrupt.

OUTEN = "1" enables the output function selected via OUTMD

When OUTEN = "0", the output is disabled and the output pin is held at a "1" level to allow several alternate functions on the same pin.

12.2.3 Timer/Counter Control

Start/Stop

ST_SP (WDTCR.7) enables down-counting. An instruction which sets this bit will cause the Timer to start at the beginning of the following instruction. Resetting this bit will stop the counter.

If the counter is stopped and restarted, counting will resume from the last value unless a new constant has been entered in the Timer registers. A new constant can be written with the counter running. The new value will be loaded at the following End Of Count (EOC).

WARNING: In order to prevent incorrect counting of the Timer/Watchdog, the prescaler (WDTPR) and counter (WDTRL, WDTRH) registers must be initialised before the starting of the Timer/Watchdog. If this is not done, counting will start with the reset (un-initialised) values.

Single/Continuous Mode

SINGLE MODE: At End Of Count the Timer stops, reloads the constant, and resets the Start/Stop bit (WDTCR.6) (user may check the current status by reading this bit). Restarting is done by setting the Start/Stop bit. Note that the Timer constant is reloaded only if it has been modified during the stop period.

CONTINUOUS MODE: At End Of Count the counter automatically reloads the constant and restarts. It is stopped only if the Start/Stop bit is reset. This Mode bit can be written with the Timer stopped or running. It is possible to toggle the S_C bit and start the counter with the same instruction.

FUNCTIONAL DESCRIPTION (Continued)

12.2.4 Timer/Watchdog Mode

In this mode (WDGEN = "0") the counter generates a fixed time basis. When End Of Count is reached the Timer generates a system Reset.

The time base is user-defined and must be written in the Timer registers before entering Watchdog mode. In Watchdog mode it is possible to modify only the Prescaler Constant. This new value will be loaded when the counter restarts.

Resetting WDGEN (bit 6 of the Wait Control Register) causes the counter to start regardless of the value of the Start-Stop. In order to prevent a system reset the sequence AAh, 55h should be entered in WDTLR (Watchdog Timer register low). Once the writing of 55h has been performed the Timer reloads the constant and counting restarts from the preset value.

The minimum time between the writing of the AAh and 55h codes is zero, i.e. the writing is sequential, and the maximum time is given by the Watchdog timeout period.

In Watchdog-mode a `halt` instruction is regarded as illegal. Execution of the `halt` instruction stops further core execution by the CPU and interrupt acknowledgment, but does not stop INTCLK or CPUCLK or the Watchdog Timer, which will cause a System Reset when reaching the End of Count. Furthermore ST_SP, S_C and input mode selection bits are "don't-care". Hence regardless of their status, the counter always runs in Continuous Mode driven by the internal clock.

The Output mode should not be enabled since that particular mode of operation is meaningless.

Figure 12-2. Timer /Watchdog in Watchdog Mode

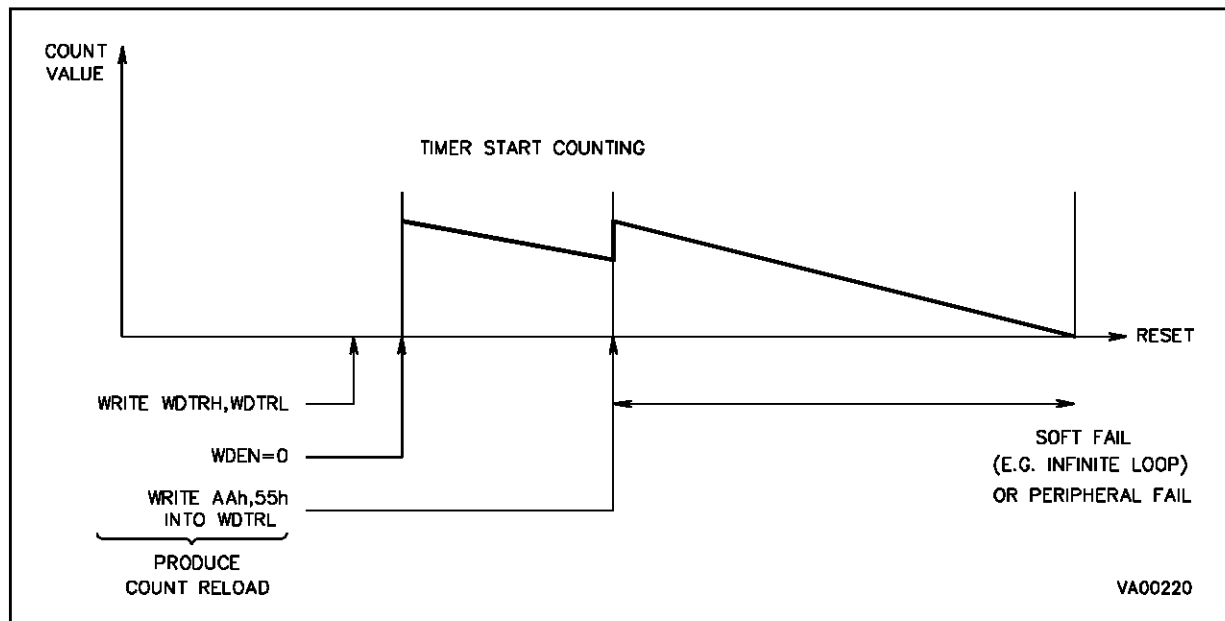

ST9 - Timer/Watchdog (ST902x)

12.3 TIMER/WATCHDOG INTERRUPT

When enabled, the Timer/Watchdog will issue an interrupt request at every End Of Count.

A pair of control bits, IAOS (EIVR.1, InterruptA0 selection bit) and TLIS (EIVR.2, Top Level Input Selection bit) allow the selection of 2 interrupt sources (the Timer/Watchdog End of Count or an external pin) in two different ways, as a top level non maskable interrupt (Software Reset) or as a source for channel A0 of the external interrupt logic.

In the Watchdog mode the End Of Count always causes a system reset.

A block diagram of the interrupt logic is given in Figure 12-3 (Note: software traps can be generated by setting the appropriate interrupt pending bit):

The following table shows all the possible configurations of the interrupt/reset sources which involve the Timer/Watchdog:

Figure 12-3. Interrupt Sources

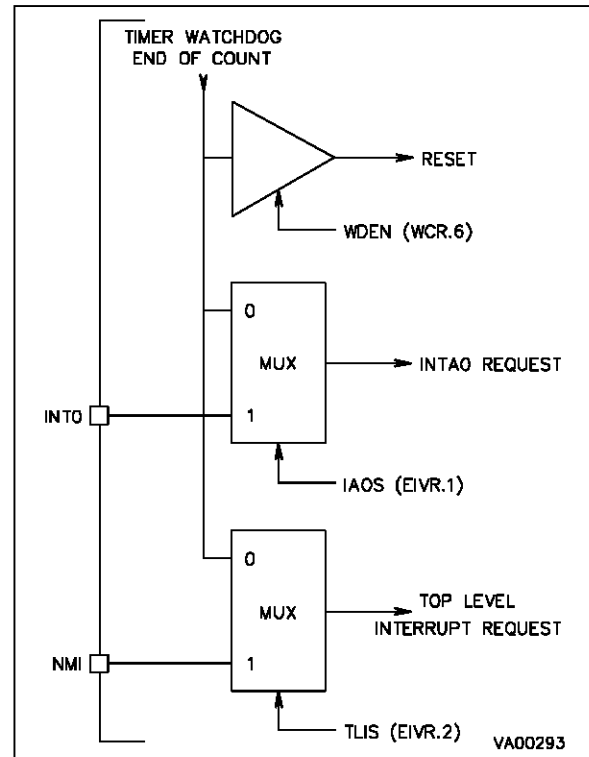

Table 12-1. Interrupt Configuration

Control Bits			Enabled Sources			Watchdog Timer Status
WDGEN	IAOS	TLIS	Reset	INTA0	Top Level	
0	0	0	WDG/Ext Reset	SW TRAP	SW TRAP	Watchdog
0	0	1	WDG/Ext Reset	SW TRAP	Ext Pin	Watchdog
0	1	0	WDG/Ext Reset	Ext Pin	SW TRAP	Watchdog
0	1	1	WDG/Ext Reset	Ext Pin	Ext Pin	Watchdog
1	0	0	Ext Reset	Timer	Timer	Timer
1	0	1	Ext Reset	Timer	Ext Pin	Timer
1	1	0	Ext Reset	Ext Pin	Timer	Timer
1	1	1	Ext Reset	Ext Pin	Ext Pin	Timer

Note.

WDG = Watchdog function
SW TRAP = Software Trap

12.4 TIMER/WATCHDOG REGISTERS

The Timer/Watchdog has 4 registers mapped into Group F, Page 0 of the Register File.

- WDTHR (R248):** Timer/Watchdog Counter High Register
- WDTLR (R249):** Timer/Watchdog Counter Low Register
- WDTPR (R250):** Timer/Watchdog Prescaler Register
- WDTCR (R251):** Timer/Watchdog Control Register

Three additional control bits are mapped in the following registers of Page 0:

- watchdog mode enable, WCR.6
- top level interrupt selection, EIVR.2
- interrupt A0 channel selection, EIVR.1

Note: The registers containing these bits also contain other functions. Only the bits relevant to the operation of the Timer/Watchdog are shown here.

Counter Registers

This 16 bit register is used to load the 16 bit counter value. The registers can be read or written “on the fly”.

WDTHR R248 (F8h) Page 0 Read/Write
Timer/Watchdog Counter Register, High byte
Reset value: undefined

7							0
R15	R14	R13	R12	R11	R10	R9	R8

WDTLR R249 (F9h) Page 0 Read/Write
Timer/Watchdog Counter Register, Low byte.
Reset value: undefined

7							0
R7	R6	R5	R4	R3	R2	R1	R0

WDTPR R250 (FAh) Page 0 Read/Write
Timer/Watchdog Prescaler Register
Reset value: undefined

7							0
PR7	PR6	PR5	PR4	PR3	PR2	PR1	PR0

b7-b0 = **PR7-PR0:** *Timer/Watchdog Prescaler.* The value stored in this Register is used to select the prescaling factor from 1 (loading 00h) to 256 (loading FFh).

WARNING. *In order to prevent incorrect counting of the Timer/Watchdog, the prescaler (WDTPR) and counter (WDTRL, WDTRH) registers must be initialised before the starting of the Timer/Watchdog. If this is not done, counting will start with the reset (un-initialised) values.*

WDTCR R251 (FBh) Page 0 Read/Write
Timer/Watchdog Control Register
Reset value: 0001 0010 (12h)

7							0
ST_SP	S_C	INMD1	INMD2	INEN	OUTMD	WROUT	OUTEN

b7 = **ST_SP:** *Start/Stop Bit.* Setting this bit to a “1” starts the counting operation (see Warning above). When this bit is “0”, the counter is stopped (reset status)

b6 = **S_C:** *Single/Continuous.* When this bit is set, the counter operates in Single Count Mode. Continuous Mode is set when this bit is “0”

b5-b4 = **INMD1, INMD2:** *Input mode selection bits.*

b3 = **INEN:** *Input Enable.* This bit enables (“1”) and disables (“0”) the input section

b2 = **OUTMD:** *Output Mode.* When this bit is “1”, and the output is enabled, the value of WROUT is transferred to the output pin on every End Of Count. When “0”, the output is toggled on every End of Count

b1 = **WROUT:** *WROUT bit.* The status of this bit is transferred to the Output pin when OUTMD = “1”, it is user definable to allow PWM output (at reset WROUT = “1”)

b0 = **OUTEN:** *Output Enable bit.* The output is enabled by setting this bit to “1”, and disabled by re-setting to “0”

ST9 - Timer/Watchdog (ST902x)

TIMER/WATCHDOG REGISTERS (Continued)

WCR R252 (FCh) Page 0 Read/Write

Wait Control Register

Reset value: 0111 1111 (7Fh)

7								0
X	WDGEN	X	X	X	X	X	X	

b6 = **WDGEN**: *Watchdog Enable Bit (active low)*. Resetting this bit to zero via software enters the Watchdog mode. Once reset, it cannot be set to “1” by the user program. At system reset, the Watchdog mode is disabled

EIVR R246 (F6h) Page 0 Read/Write

External Interrupt Vector Register

Reset value: xxxx 0110 (X6h)

7								0
X	X	X	X	X	TLIS	IAOS	X	

b2 = **TLIS**: *Top Level Input Selection bit*. This bit selects the Top Level interrupt source. When “0”, the Top Level interrupt source is the Watchdog/Timer end of count, when = “1”, it is the external pin NMI.

b1 = **IAOS**: *Interrupt channel A0 Selection Bit*. This bit allows the Timer/Watchdog interrupt to channel through the external Interrupt A0 source, allowing the setting of user-defined priority levels.

WARNING. *To avoid spurious interrupt requests, an access to the IAOS bit must be made only when the interrupt logic is disabled (i.e. after the DI instruction). It is also necessary to clear a possible interrupt pending request on channel A0 before enabling this interrupt channel. A delay instruction (e.g. a NOP instruction) must be inserted between the reset of the interrupt pending bit and the IAOS write instruction.*

13 MULTIFUNCTION TIMER

13.1 INTRODUCTION

The Multifunction Timer is a 16-bit Up/Down counter, driven by the output of an 8-bit prescaler which may be driven by INTCLK/3 (giving a minimum timing resolution of 250ns at INTCLK = 12 MHz) or by an external source.

This timer is supported by two 16-bit Comparison Registers (CMP0R, CMP1R) for generating timed functions and two 16-bit Capture/(re)Load Registers (REG0R, REG1R) for timing and variable timebase functions. These features coupled with 2 input pins (TxINA and TxINB) and 2 Alternate Function output pins (TxOUTA and TxOUTB), where x = the number of the Timer, give the Timer 12 operating modes including automatic PWM generation and frequency measurement.

Several functional configurations are possible, e.g.:

- 2 input captures on two different external lines and 2 independent output compare functions (counter in free running mode), or 1 output compare on a fixed repetition rate.
- 1 input capture, 1 counter reload and 2 independent output compares.

- 2 alternate autoreloads and 2 independent output compares.
- 2 alternate captures on the same external line and 2 independent output compares on a fixed repetition rate.

When two timers are present on ST9 chip, a combined mode is available.

Four internal signals are also available for timing of on-chip functions: the On Chip Event signal can be used to control other peripherals on the chip itself, and 3 other signals which can be internally connected to I/O port(s) in order to allow automatic, timed, DMA transfers.

The two external inputs (TxINA/TxINB) of the timer can be individually programmed to catch a particular external configuration, i.e.:

- rising edge
- falling edge
- rising and falling edges

The configuration of each input is fixed by the Input Control Register (ICR).

Figure 13-1. MFT Simplified Block Diagram

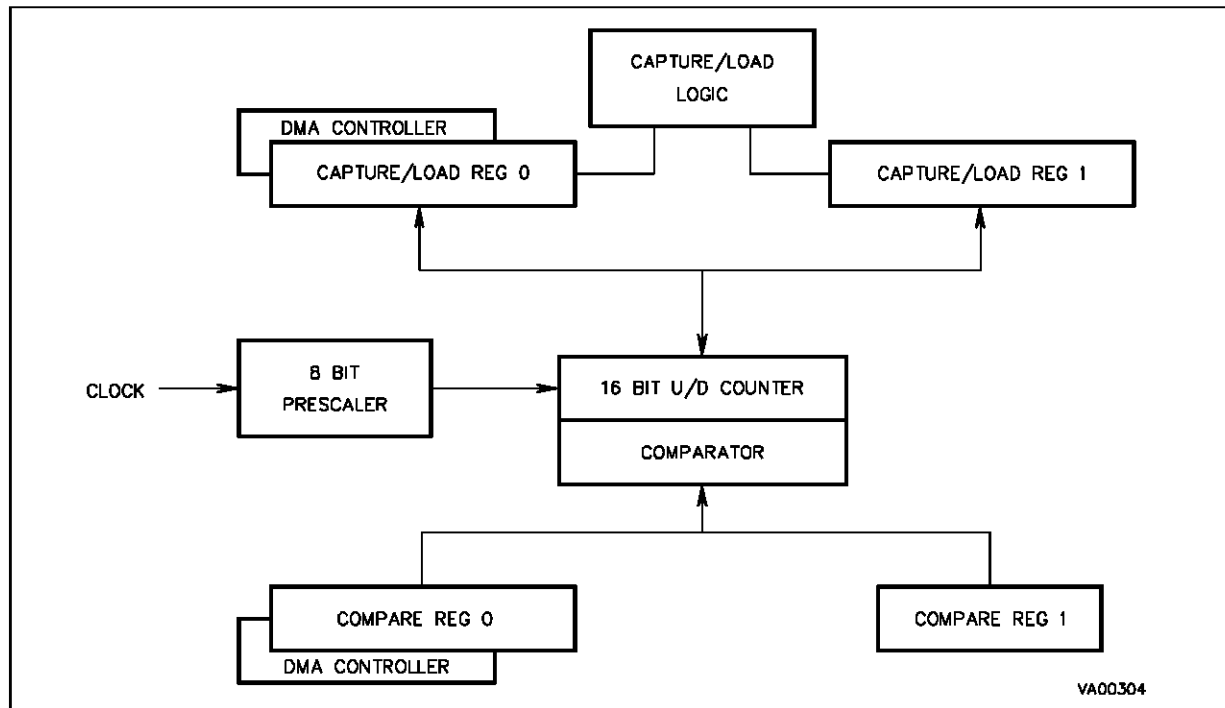

ST9 - Multifunction Timer (ST902x)

INTRODUCTION (Continued)

Each of the two output pins (TxOUTA/TxOUTB) can be driven from any of three possible sources:

- Compare Register 0 logic
- Compare Register 1 logic
- Overflow/Underflow logic

Each of these three sources can cause one of the following four effects, independently, on each of the two outputs:

- Nop
- Set
- Reset
- Toggle

Furthermore an additional on-chip Event signal can be generated by two of the three sources mentioned above, i.e. Over/Underflow event and Compare 0 event. This signal can be used internally as synchronism for another on-chip peripheral or as strobe for an I/O port (see I/O port chapter).

Five maskable interrupt sources referring to an End Of Count condition, 2 input captures and 2 output compares, can generate 3 different interrupt requests (with hardware fixed priority), pointing to 3 interrupt routine vectors.

Two independent DMA channels are available for a MTimer and can be used for quick data flow operations. Each DMA request (associated to a capture on REGOR register, or a compare on CMPOR register) has priority on the INT request generated by the same source.

Each DMA channel can be employed in external transfers to/from memory from/to an I/O port using three internal lines (one for setting the data flow direction, and two for the transfer synchronization).

A SWAP mode is also available to allow high speed continuous transfers (see Interrupt and DMA chapter).

Figure 13-2. Detailed Block Diagram

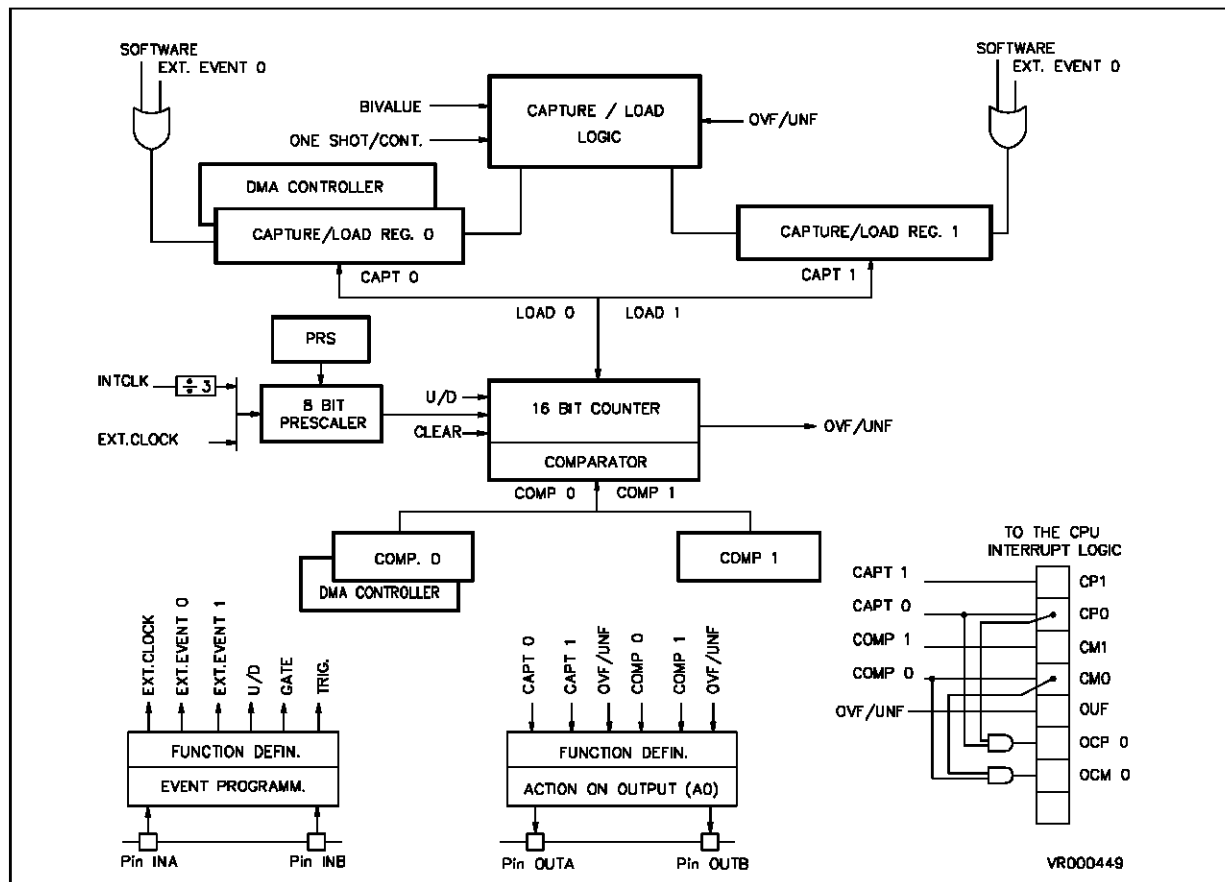

13.2 FUNCTIONAL DESCRIPTION

The operating modes of the timer can be selected by programming the Timer Control Register (TCR) and the Timer Mode Register (TMR).

13.2.1 One Shot Mode

When the counter generates an overflow (in up-count mode) or an underflow (in down-count mode), i.e. an End Of Count is reached, the counter stops and no counter reload occurs. The counter can be restarted only by an external or software trigger. The One Shot Mode is entered by setting TMR bit CO.

13.2.2 Continuous Mode

Whenever the counter reaches an End Of Count, the counting sequence is automatically restarted and the counter is reloaded from REG0R (or REG1R when selected in Biload Mode). Continuous Mode is entered by resetting TMR bit C0.

13.2.3 Trigger And Retrigger Modes

A trigger event may be generated either by software action (setting either CP0 or CP1 bit in timer register FLAGR), or by an external source which may be programmed to be active on the rising edge, the falling edge or both, using the fields A0-A1 and B0-B1 in ICR.

In One Shot and Trigger Mode, every trigger event (used as a reload and start count) arriving before an End Of Count, is masked. In One Shot and Retrigger Mode, every trigger (used as a reload and start count) received while the counter is running automatically reloads the counter from REG0R (or REG1R when the register is selected in Biload Mode). Trigger/Retrigger Mode is set by the REN bit in TMR.

TxINA input refers to REG0R and TxINB input refers to REG1R.

WARNING. *If the Trigger Mode is selected when the counter is in Continuous Mode, then every trigger to reload the counter starting value is disabled, so it is not possible to synchronize the counting cycle by hardware or software.*

13.2.4 Gate Mode

In this mode the counting operation is performed only when the external gate input is active (logical state "0"). The selection of TxINA or TxINB input as gate input is made through IN0-IN3 bits in ICR.

13.2.5 Capture Mode

REG0R and REG1R registers may be independently set in Capture Mode by setting RM0 or RM1 in TMR, so that a capture of the current count value can be performed either on REG0R or REG1R, via software action (by setting CP0 or CP1 in the FLAGR register) or a programmable event on the external input pins.

WARNING. *Care should be taken when two software captures have to be performed on the same register. In this case, at least one extra instruction must be present between the first CP0/CP1 bit set and the subsequent CP0/CP1 bit reset.*

13.2.6 Up/Down Mode

The counter can count up or down depending on the state of the UDC bit (Software Up/Down) in TCR, or on the configuration of the external input pins, which have priority over UDC (see Input pin assignment in ICR). When read, the UDCS bit always returns the counter up/down current status (see also the Up/Down Autodiscrimination mode in the Input Pin Assignment Section).

13.2.7 Free Running Mode

The timer performs full range counting (in up or down mode) without reloading from REG0R at an End Of Count. This mode is automatically selected either in Bicapture Mode or by setting REG0R for capture function (Continuous Mode must also be set). In Autoclear Mode, free running with modulo less than 2^{16} may be obtained (see Autoclear Mode).

FUNCTIONAL DESCRIPTION (Continued)

13.2.8 Monitor Mode

When RM1 bit in TMR is reset and the timer is not in Bivalue Mode, then REG1R acts as monitor, reproducing the current U/D counter content enabling the ST9 to read the counter “on the fly”.

13.2.9 Autoclear Mode

A clear command forces the counter to the value 0000h or 0FFFFh, when counting in up or down count mode respectively. The counter reset may be obtained either directly, through CCL bit in TCR, or by entering the Autoclear Mode, through CCP0 and CCMP0 fields in TCR.

Every capture performed on REG0R (if CCP0 = “1”), or every successful compare performed by CMP0R (if CCMP0 = “1”), clears the counter and reloads the prescaler.

The Clear On Capture mode allows the direct measurement of delta time between successive captures on REG0R, while the Clear On Compare mode allows free running with modulo less than 2^{16} .

13.2.10 Bivalue Mode

Depending on the value of RM0 bit in TMR, the BiLoad Mode (RM0 = “0”) or the Bicapture Mode (RM0 = “1”) can be selected as explained in the following table:

Table 13-1. Bivalues Modes

TMR bits			Timer Operating Modes
RM0	RM1	BM	
0	X	1	BiLoad mode
1	X	1	BiCapture Mode

A) BiLoad Mode

The BiLoad Mode is entered by selecting the Bivalue Mode (BM = “1” in TMR) and programming REG0R as a reload register (RM0 = “0” in TMR).

At any End Of Count, the counter reloading is performed alternately from REG0R and REG1R, (a low level for BM bit always sets REG0R as the current register, so that, after a Low to High transition of BM bit, the first reload is always from REG0R).

Every software or external trigger event on REG0R performs a reload from REG0R resetting the BiLoad cycle. In One Shot mode (reload made by a software or external trigger), the reload is always from REG0R.

B) Bicapture Mode

The Bicapture Mode is entered selecting the Bivalue Mode (BM = “1” in TMR) and programming REG0R as a capture register (RM0 = “1” in TMR).

Every capture event, software simulated (by setting CP0 flag) or from the TxINA input line, captures the current counter value alternately into REG0R and REG1R. A low level for BM bit always sets REG0R as current register, so that the first capture, after setting BM bit, is always into REG0R.

13.2.11 Parallel Mode

When there are two timers on ST9 chip, the parallel mode is entered with ECK = “1” in TMR of Timer 1. Timer 1 prescaler input is internally connected to the Timer 0 prescaler output. Timer 0 prescaler input is connected to the system clock line.

By loading the Prescaler Register of Timer 1 with the value 00h the two timers (Timer 0 and Timer 1) are driven by the same frequency in parallel mode.

13.2.12 Autodiscriminator Mode

Figure 13-3. Parallel Mode Description

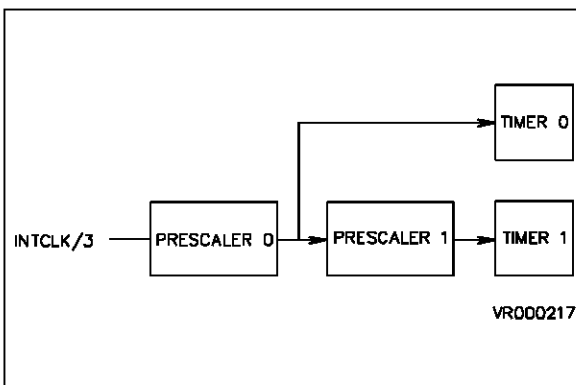

The phase difference sign of two overlapped pulses (respectively on TxINB and TxINA) generates a one step up(down) count, so that the up/down control and the counter clock are both external. The setting of the UDC bit in the TCR register has no effect in this configuration.

13.3 INPUT PIN ASSIGNMENT

The two external inputs (TxINA and TxINB) of the timer can be individually configured to catch a particular external event (i.e. rising edge, falling edge, rising and falling edges) by programming the two relevant bits (A0, A1 and B0, B1) for each input in the external Input Control Register (ICR).

The 16 different functional modes of the two external inputs can be selected by programming IN0 - IN3 bits of the ICR as explained in the following table.

Table 13-2. Input Pin Function

I C Reg. IN3-IN0 bits	TxINA Input Function	TxINB Input Function
0000	not used	not used
0001	not used	Trigger
0010	Gate	not used
0011	Gate	Trigger
0100	not used	Ext. Clock
0101	Trigger	not used
0110	Gate	Ext. Clock
0111	Trigger	Trigger
1000	Clock Up	Clock Down
1001	Up/Down	Ext. Clock
1010	Trigger Up	Trigger Down
1011	Up/Down	not used
1100	Autodiscr.	Autodiscr.
1101	Trigger	Ext. Clock
1110	Ext. Clock	Trigger
1111	Trigger	Gate

Some choices in the external input pin assignment are defined in conjunction with RM0 and RM1 bits in TMR.

For input pin assignment codes using the input pins as Trigger Inputs (except for code 1010, Trigger Up:Trigger Down):

- a trigger signal on TxINA input pin performs an U/D counter load if RM0 = "0", or an external capture if RM0 = "1".
- a trigger signal on TxINB input pin always performs an external capture on REG1R. The TxINB input pin is disabled when the Bivalue Mode is set.

Note. For proper operation of the External Input pins, the following must be observed:

- the minimum external clock/trigger pulse width cannot be less than the system clock (INTCLK) period if the input pin is programmed as rising or falling edge sensitive.
- the minimum external clock/trigger pulse width cannot be less than the prescaler clock period

(INTCLK/3) if the input pin is programmed as rising and falling edges sensitive (valid also in Autodiscrimination mode). - the minimum delay between two clock/trigger pulse active edges must be greater than the prescaler clock period (INTCLK/3), while the minimum delay between two consecutive clock/trigger pulses must be greater than the system clock (INTCLK) period.

- the minimum gate pulse width must be at least twice the prescaler clock period (INTCLK/3).
- in Autodiscrimination mode, the minimum delay between the input pin A pulse edge (inside the input pin B pulse) and the edges of the input pin B pulse, must be at least the system clock (INTCLK) period.
- if a number N of external pulses must be counted using a Compare Register of a Timer in External Clock mode, then the Compare Register used must be loaded with the value $[X \pm (N-1)]$, where X is the starting counter value and the sign is chosen depending if in Up or Down count mode respectively.

The sixteen external input functional modes available (referring to Table 13-2) are:

13.3.1 TxINA = I/O - TxINB = I/O

Input pins A and B are not used by the Timer. The counter clock is internally generated and the up/down control may be made only by software action through the UDC (Software Up/Down) bit in the TCR register.

13.3.2 TxINA = I/O - TxINB = Trigger

The signal applied to input pin B acts as a trigger signal on REG1R register. The prescaler clock is internally generated and the up/down control may be made only by software action through the UDC bit in the TCR register.

13.3.3 TxINA = Gate - TxINB = I/O

The signal applied to input pin A acts as a gate signal for the internal clock (i.e. the counter runs only when the gate signal is at a low level). The counter clock is internally generated and the up/down control may be made only by software action through the UDC bit in the TCR register.

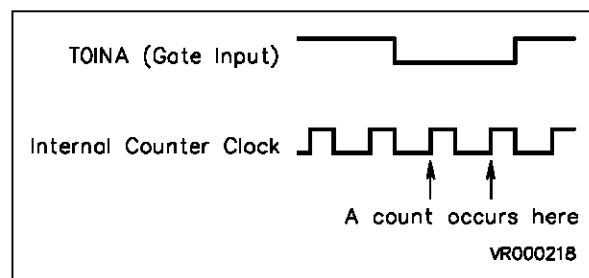

INPUT PIN ASSIGNMENT (Continued)

13.3.4 TxINA = Gate - TxINB = Trigger

Both input pins A and B are connected to the timer, with the resulting effect of combining the actions due to the above explained configurations.

13.3.5 TxINA = I/O - TxINB = Ext. Clock

The signal applied to input pin B is used as the external clock for the prescaler. The up/down control may be made only by software action through the UDC bit in the TCR register.

13.3.6 TxINA = Trigger - TxINB = I/O

The signal applied to input pin A acts as a trigger signal on REG0R register performing the action for which the register was programmed (i.e. a reload or capture). The prescaler clock is internally generated and the up/down control may be made only by software action through the UDC bit in the TCR register.

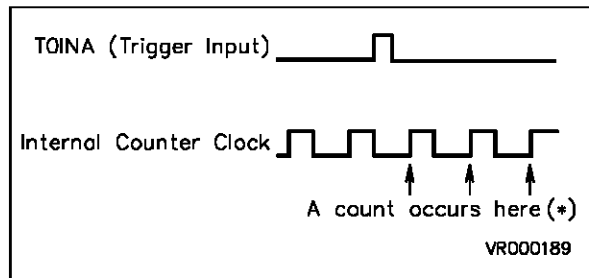

(*) The timer is in One shot mode and REG0R in Reload mode

13.3.7 TxINA = Gate - TxINB = Ext. Clock

The signal applied to input pin B, gated by the signal applied to input pin A, acts as external clock for the prescaler. The up/down control may be made only by software action through the UDC bit in the TCR register.

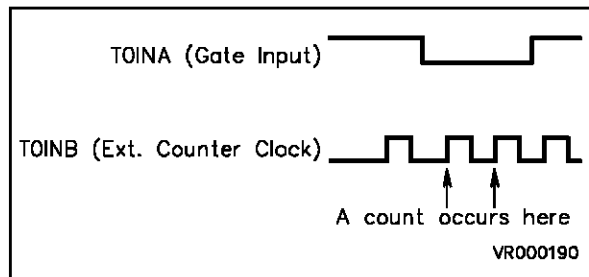

13.3.8 TxINA = Trigger - TxINB = Trigger

The signal applied to input pin A (or B) acts as trigger signal for the REG0R (or REG1R) register performing the action for which the register has been programmed. The counter clock is internally generated and the up/down control may be made only by software action through the UDC bit in the TCR register.

13.3.9 TxINA = Clock Up - TxINB = Clock Down

The pulse received on input pin A (or B) performs a one step up (or down) count, so that the counter clock and the up/down control are external. Setting the UDC bit in the TCR register has no effect in this configuration while input pin B has priority on input pin A.

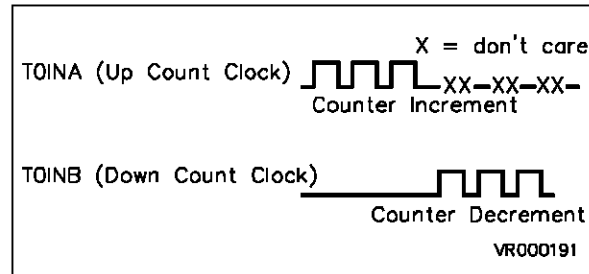

13.3.10 TxINA = Up/Down - TxINB = Ext Clock

An High (or Low) level of the signal applied on input pin A sets the counter in the up (or down) count mode, while the signal applied to input pin B is used as clock for the prescaler. Setting the UDC bit in the TCR register has no effect in this configuration.

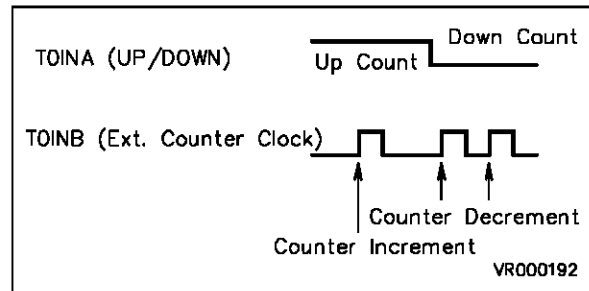

INPUT PIN ASSIGNMENT (Continued)

13.3.11 TxINA = Trigger Up - TxINB = Trigger Down

Up/down control is performed through both input

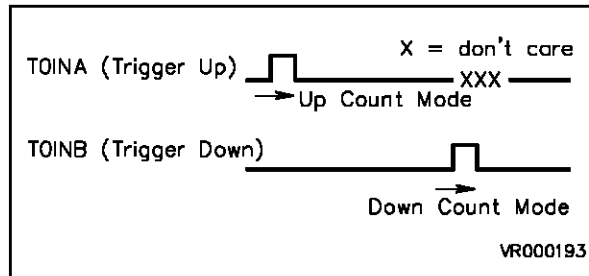

pins A and B. A pulse on input pin A sets the up count mode, while a pulse on input pin B (which has priority on input pin A) sets the down count mode. The counter clock is internally generated while setting the UDC bit in the TCR register has no effect in this configuration.

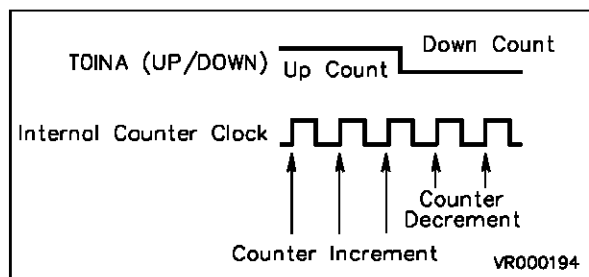

13.3.12 TxINA = Up/Down - TxINB = I/O

An High (or Low) level of the signal applied on input pin A sets the counter in the up (or down) count mode. The counter clock is internally generated. Setting the UDC bit in the TCR register has no effect in this configuration.

13.3.13 Autodiscrimination Mode

The phase between two pulses (respectively on input pin B and input pin A) generates a one step up (or down) count, so that the up/down control and the counter clock are both external. Thus, if the rising edge of TxINB arrives when TxINA is at level "0" the timer is incremented (no action if the rising edge of TxINB arrives when TxINA is at level "1"). If the falling edge of TxINB arrives when TxINA is at level "0" the timer is decremented (no action if the falling edge of TxINB arrives when TxINA is at level "1").

Setting the UDC bit in the TCR register has no effect in this configuration.

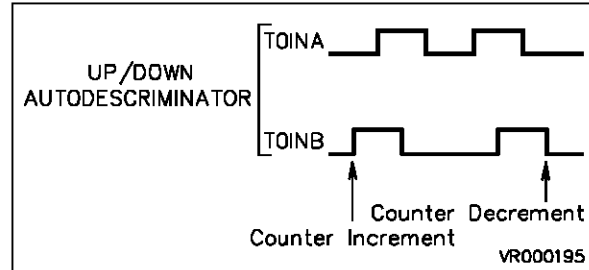

13.3.14 TxINA = Trigger - TxINB = Ext. Clock

The signal applied to input pin A acts as a trigger signal on REG0R register performing the action for which the register was programmed (i.e. a reload or capture), while the signal applied to input pin B is used as clock for the prescaler.

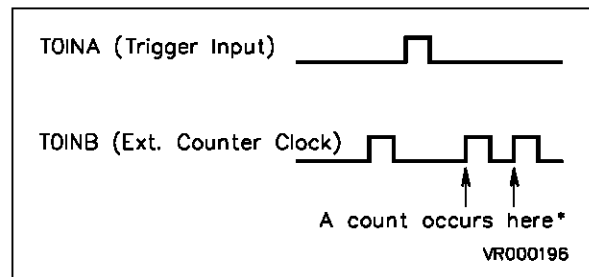

(*) The timer is in One shot mode and REG0R in reload mode

13.3.15 TxINA = Ext. Clock - TxINB = Trigger

The signal applied to input pin B acts as a trigger, performing a capture on REG1R register, while the signal applied to the input pin A is used as clock for the prescaler.

13.3.16 TxINA = Trigger - TxINB = Gate

The signal applied to input pin A acts as a trigger signal on REG0R register performing the action for which the register was programmed (i.e. a reload or capture), while the signal applied to input pin B acts as a gate signal for the internal clock (i.e. the counter runs only when the gate signal is at a low level).

ST9 - Multifunction Timer (ST902x)

13.4 OUTPUT PIN ASSIGNMENT

Two external outputs are available for each timer when programmed as Alternate Function Outputs of the I/O pins.

Two registers for every timer, Output A Control Register (OACR) and Output B Control Register (OBCR) define the driver for the outputs and the actions to be performed.

Each of the two output pins can be driven from any of the three possible sources:

- Compare Register 0 event logic
- Compare Register 1 event logic
- Overflow/Underflow event logic.

Each of these three sources can cause one of the following four effects on any of the two outputs:

- Nop
- Set
- Reset
- Toggle.

Furthermore an On Chip Event signal can be driven by two of the three sources: the Over/Underflow event and Compare 0 event by programming the CEV bit of the OACR register and the OEV bit of OBCR register respectively. This signal can be used for another on-chip peripheral or as strobe for an I/O port (see Handshake chapter).

Output Waveforms

Table 13-3. On-chip Event Settings

MFT0	Handshake Trigger Port 5
------	--------------------------

Depending on the different programmed values of OACR and OBCR the following example waveforms can be generated on TxOUTA and TxOUTB pins.

Configuration where TxOUTA is driven by Over/Underflow (OUF) and Compare 0 event (CM0), while TxOUTB is driven by the Over/Underflow and Compare 1 event (CM1).

OACR is programmed with TxOUTA preset to "0", OUf sets TxOUTA, CM0 resets TxOUTA and CM1 does not affect the output.

OBCR is programmed with TxOUTB preset to "0", OUf sets TxOUTB, CM1 resets TxOUTB while CM0 does not affect the output.

Configuration where TxOUTA is driven by

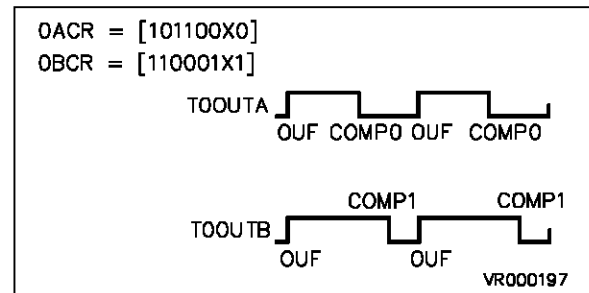

Over/Underflow, Compare 0 and Compare 1, while TxOUTB is driven by both Compare 0 and Compare 1.

OACR is programmed with TxOUTA preset to "0". OUf toggles the Output 0 as do CM0 and CM1.

OBCR is programmed with TxOUTB preset to "1". OUf does not affect the output while CM0 resets TxOUTB and CM1 sets it.

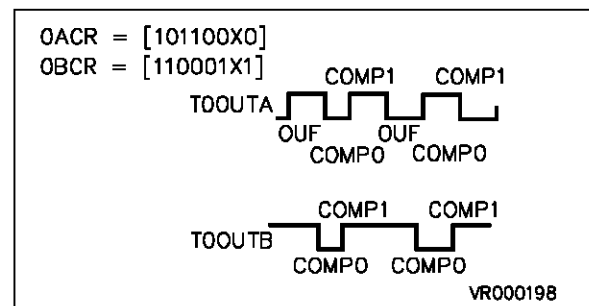

OUTPUT PIN ASSIGNMENT (Continued)

Configuration where TxOUTA is driven by Over/Underflow and Compare 0, while TxOUTB is driven by Over/Underflow and Compare 1. OACR is programmed with TxOUTA preset to "0". OUF sets TxOUTA while CM0 resets it and CM1 has no affect. OBCR is programmed with TxOUTB preset to "1". OUF toggles TxOUTB, CM1 sets it and CM0 has no affect.

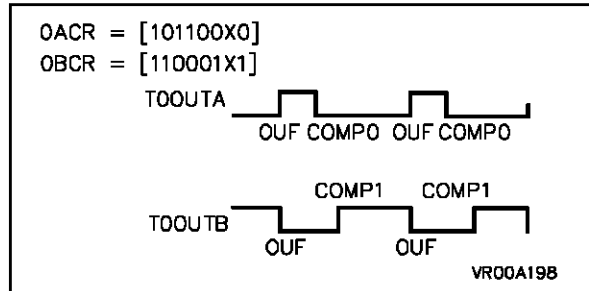

Configuration where TxOUTA is driven by Over/Underflow and Compare 0, while TxOUTB is driven by Compare 0 and 1. OACR is programmed with TxOUTA preset to "1". OUF sets TxOUTA, CM0 resets it and CM1 has no affect. OBCR is programmed with TxOUTB preset to "0". OUF has no affect, CM0 sets TxOUTB and CM1 toggles it.

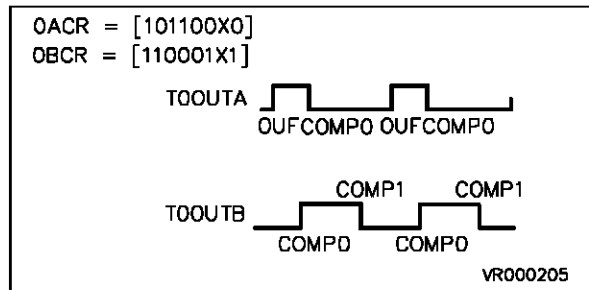

Output Waveform Samples In Biload Mode

TxOUTA is programmed to monitor the two time intervals (t1 and t2) of the Biload Mode while TxOUTB is independent from the Over/Underflow and is driven by the different values of Compare 0 and Compare 1.

OACR is programmed with TxOUTA preset to "0". OUF toggles the output and CM0 and CM1 do not affect TxOUTA.

OBCR is programmed with TxOUTB preset to "0". OUF has no effect, while CM1 resets TxOUTB and CM0 sets it.

Depending on the CM1/CM0 values, three different example waveforms have been drawn starting from the above mentioned configuration of OBCR. In the last case, with a different programmed value of OBCR, only Compare 0 drives TxOUTB, toggling the output.

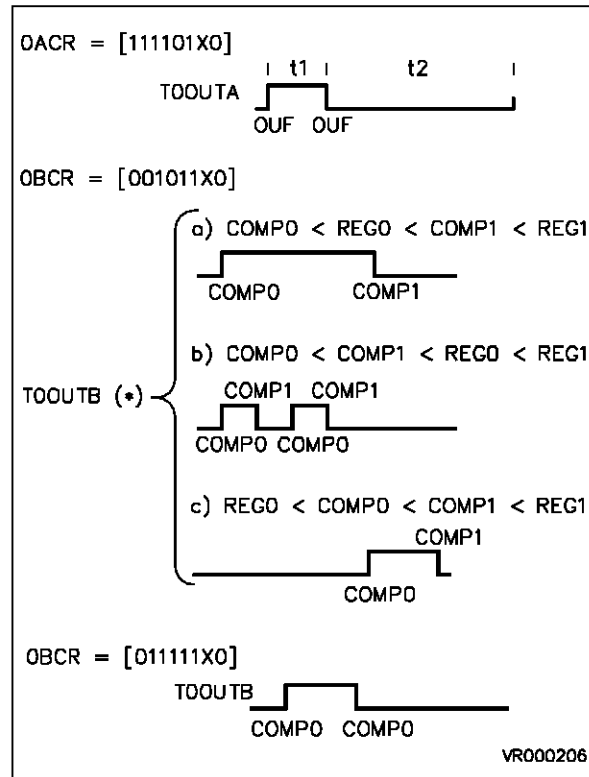

Note (*) Depending on the CMP1R/CMP0R values

13.5 INTERRUPT AND DMA

13.5.1 Timer Interrupt

The timer has 5 different Interrupt sources, grouped into 3 independent groups, assigned to the following Interrupt vectors:

Table 13-4. Timer Interrupt Structure

Interrupt Source	Vector Address
COMP 0 COMP 1	xxxx x110
CAPT 0 CAPT 1	xxxx x100
Overflow/Underflow	xxxx x000

The three least significant bits of the vector pointer address represent the relative priority assigned to each group, (000 value is the highest priority level) and are fixed by hardware depending on the source which generates the interrupt request. The 5 most significant bits are programmed by the user in the Interrupt Vector Register (IVR) of each Timer.

Each source can be masked by a dedicated bit in the Interrupt/DMA Mask Register (IDMR) of each timer, as well as a global mask enable bit (IDMR.7), masking all interrupts.

If an interrupt request (CM0 or CP0) happens before the corresponding pending bit is reset, an overrun condition occurs. This condition is flagged in two dedicated overrun bits, concerning the Comp0 and Capt0 sources, and placed in the Timer Flag Register (FLAGR).

13.5.2 Timer DMA

Two Independent DMA channels, associated to Compare 0 and Capture 0 sources, respectively allow DMA transfers from Register File/Memory to Comp0 Register and vice versa from Capt0 Register to Register File/Memory (also transfers in/from Memory from/into an I/O port are available). Their priority is hardware set as follows:

- Compare 0 Destination Lower Priority
- Capture 0 Source Higher Priority

The two DMA request sources are independently maskable by two DMA Mask bits, mapped in the Timer Interrupt/DMA Mask register (IDMR).

The two End of Block procedures, associated to each Interrupt mask and DMA mask combination, follow the standard architecture as shown in the Interrupt and DMA chapters.

13.5.3 DMA Pointers

The 6 programmable most significant bits of the Timer Address and Counter Pointer registers (DAPR-DCPR) are common to both channels (Comp0 and Capt0 sources). As a consequence, the Comp0 and Capt0 Address pointers are mapped by pair in the Register File, as well as the Comp0 and Capt0 DMA Counter pair.

The different address specification, in order to point either Capt0 or Comp0 pointers, is provided by the Timer according to the channel under service (replacing the address bit 1 with "0" for CAPT0 or with "1" for COMP0), when D0 bit on DCPR register is equal to zero (Word address in Register File). In this condition (register with program/data memory transfer), the pointers will be split in two groups of adjacent Address pointer and Counter pairs respectively.

In the case of register to register transfers (selected by programming the value "1" into bit 0 of the DCPR register), only one pair of pointers are required and the pointers are mapped into one group of adjacent positions.

DAPR (the DMA/Address Pointer Register) in this case is not used, but must be considered reserved.

INTERRUPT AND DMA (Continued)

Figure 13-4. Map Pointer for Register to Prog/Data Memory Transfer

Address Pointers	Register File	
	Comp0 16 bit Addr Pointer	YYYYYY11(l) YYYYYY10(h)
	Capt0 16 bit Addr Pointer	YYYYYY01(l) YYYYYY00(h)
DMA Counters	Comp0 DMA 16 bit Counter	XXXXXX11(l) XXXXXX10(h)
	Capt0 DMA 16 bit Counter	XXXXXX01(l) XXXXXX00(h)

Figure 13-5. Map Pointer for Register to Register Transfer

Register File		
8 bit Counter	XXXXXX11	Compare 0
8 bit Addr Pointer	XXXXXX10	
8 bit Counter	XXXXXX01	Capture 0
8 bit Addr Counter	XXXXXX00	

13.5.4 Priority During The DMA Transactions

Each Timer DMA transaction is a 16-bit operation, therefore two different bytes must be transferred subsequently. This is accomplished by two DMA transfers. In order to speed up each word transfer, the second byte transfer is executed by forcing automatically the peripheral priority to the highest level (000) regardless to the previous set level. It will be then restored to the original value after executing this transfer. Furthermore, once one request is being served, its hardware priority is kept at the highest level regardless to the other Timer internal sources, i.e. once a Comp0 request is being served, it keeps a higher priority on the Capt0 channel, even if a Capt0 request occurs between the two byte transfers.

13.5.5 The DMA Swap Mode

After a complete data table transfer, the transaction counter is reset and an End Of Block condition occurs, the block transfer is completed.

The End Of Block Interrupt routine has at this point to reload both address and counter pointers of the channel referred by the End Of Block interrupt source if the application requires a continuous high speed data flow. This procedure causes speed limitations because of the time consumed by the reload routine.

The SWAP feature overcomes this drawback, allowing high speed continuous transfers. Bit 2 of the Timer Address and Counter Pointer registers (DAPR-DCPR), toggles after any End Of Block condition, alternately providing odd and even address (D2-D7) for the pair of pointers, thus pointing to an updated pair, after a block has been completely transferred. This allows the User to be updating or reading the first block, and to update the pointer values while the second is being transferred. These two toggle bits are software writable and readable, mapped in DCPR bit 2 for the CM0 channel, and in DAPR bit 2 for the CP0 channel (though a DMA event on a channel, in Swap mode, modifies a field in DAPR and DCPR common to both channels, the DAPR/DCPR content used in the transfer is always the bit related to the correct channel).

The SWAP mode can be enabled by a control bit placed in the Interrupt Control Register.

WARNING: this mode is always set for both channel (CM0 and CP0).

INTERRUPT AND DMA (Continued)

13.5.6 The DMA End Of Block Interrupt Routine

This Interrupt request is generated after each block transfer (EOB) and its priority is the same as assigned in the usual Interrupt request, for the two channels. As a consequence, they will be served only when no DMA request occurs, and will be submitted to a possible OUF Interrupt request, which has higher priority.

Here is a typical EOB procedure (with swap mode enabled):

- Toggle bit test and Jump.
- Pointers (odd or even depending on toggle bit status) reload.
- Reset EOB bit: this bit must be reset only after the old couple of pointers has been restored, so that, if a new EOB condition occurs, the next pointers are ready to be swapped.
- Verify the software protection condition.
- Read the corresponding Overrun bit: this makes the user sure that NO DMA request has been lost in the meantime.
- Return.

WARNING: *The EOB bits are read/write bits only for testing reasons. Writing a logical "1" by software (when SWEN bit is set) will cause a spurious interrupt request. During normal operation, these bits must only be reset by software.*

13.5.7 DMA Software Protection

A second EOB condition may occur before the first EOB routine is completed, this would cause a not yet updated pointer couple to be addressed, with consequent overwriting of memory. To prevent these errors, a protection mechanism is provided, such that the attempted setting of the EOB bit before it has been reset by software will cause the DMA mask on that channel to be reset (DMA disabled), locking any further DMA operation. As shown above, this mask bit should always be checked in each EOB routine, to ensure all DMA transfers are properly served.

13.6 TIMER DMA EXTERNAL MODES ON I/O PORTS

Each Timer DMA channel can also be employed in external transfers to/from memory from/to an I/O port. In this case only Byte transfers are executed for any request. Two control bits (DCTS and DCTD) in the Interrupt/DMA Control Register (IDCR) set each channel in INT/EXT (Internal = Register to Memory/External = Memory to/from I/O ports) mode.

The relevant I/O port must then be programmed in DMA mode and the right direction of the port chosen by the HDCxR register of that port (see Handshake chapter).

The two modes, however, are not the same for both channels as explained in the following section.

13.6.1 CM0 Channel External Mode

This mode is enabled when DCTD (DMA Compare Transaction Destination) bit is equal to "1" in the IDCR register.

This mode allows only Output transfers, from Register File/memory to the I/O port, under a request caused by a CM0 event or a software request (writing "1" in the CM0 flag). An application for this is a data flow under DMA to be output at fixed times.

The synchronization with the I/O port is accomplished by an internal signal, active when the data to be transferred is present on the internal Data Bus. If programmed, the on-chip event pulse can also be generated and used to strobe the output data on the selected handshake port.

In either case the DMA Output mode must be selected in the HDCTL Register of the port (see Handshake chapter).

13.6.2 CP0 Channel In External Mode

This mode is enabled when DCTS (DMA Capture Transaction Source) bit is equal to "1" in the IDCR register.

This mode allows bi-directional transfers controlled (when the I/O port is programmed in DMA Input/Output mode in the HDCTL register) by the value of the DD bit of the HDCTL register (the DD bit selects the DMA input or DMA Output mode).

The DMA request can be either an External CPT0 request (Timer External input A) or a software request (by writing "1" in the CP0 Flag).

This, along with a further internal synchronization signal, generated by the Timer Unit, allows handshake operations managed by the I/O port while the direction of the data to read or write on the I/O port is fixed by the value of the DD bit in the HDCTL register.

MODES ON I/O PORTS (Continued)

13.6.3 DMA Channel Synchronization

A CP0 DMA request can be generated also by a CM0 event, simply by setting the Timer External Input A on rising and falling edges sensitive, connecting it by hardware or software (though the IOCR register) to the Timer OUT 0, and programming the CM0 action as output toggle.

This will cause a CP0 request to be generated after

each CM0 condition, thus synchronizing the 2 DMA channels (see the following application example).

The DCTS bit must be set and DCTD bit must be reset in the IDCR register. Figure 13-6 shows an example of two channel synchronisation. A new byte will be sent out through the I/O port at an interval specified by the COMP0 value mapped in the look-up table.

Figure 13-6. Timer DMA Channels Synchronization

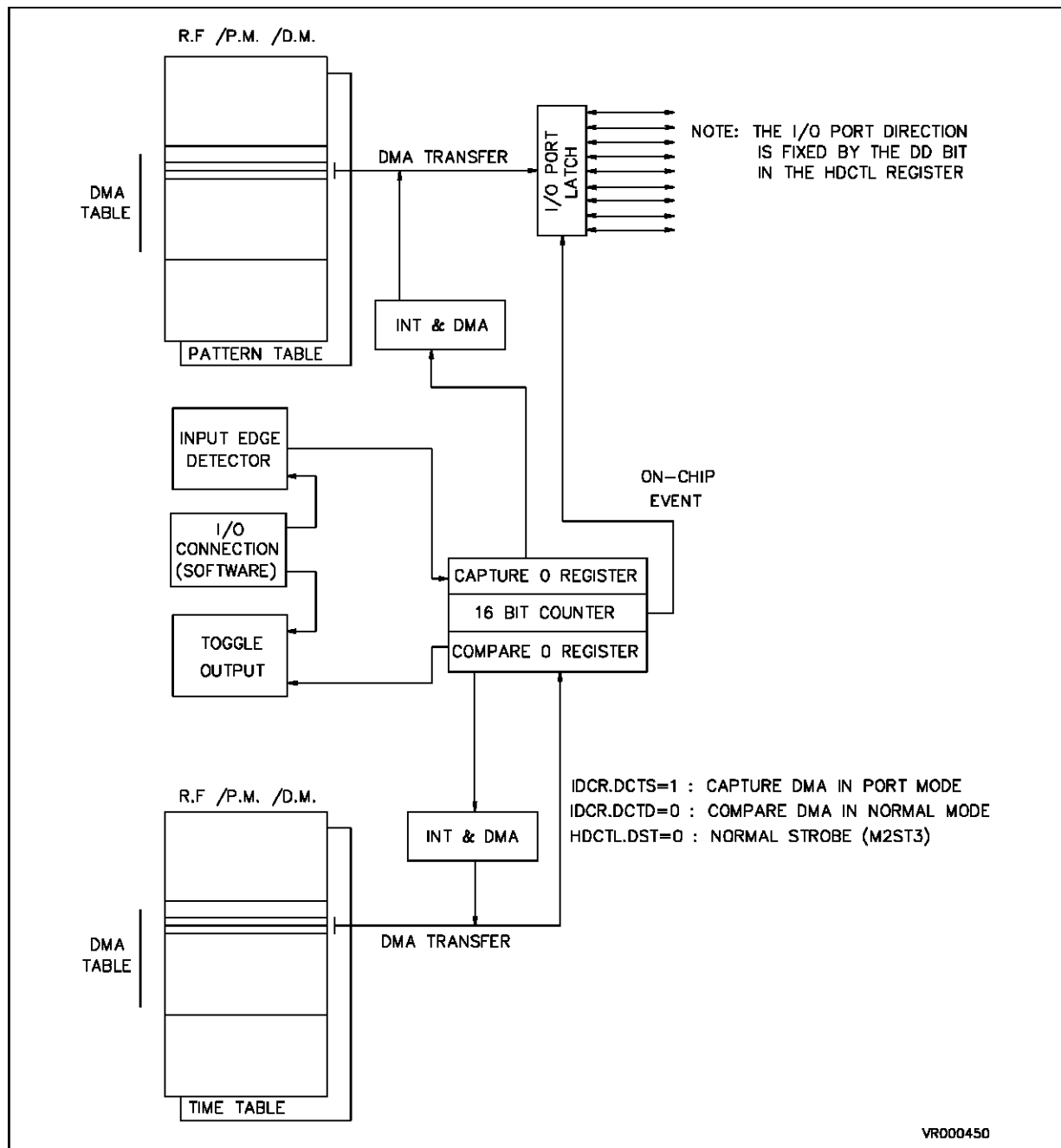

ST9 - Multifunction Timer (ST902x)

13.7 REGISTER DESCRIPTION

Twenty control and data registers are associated to each Multifunction timer, and are located in the Group F I/O pages of the ST9 Register File.

The registers of the Multifunction Timers are located in the I/O pages as follows:

Note that unused registers must be regarded as reserved registers.

In the following pages there is a detailed description of every register with the meaning and the function of every bit. The register is referred to without the absolute address which is dependent on the number of the timer used (the configuration and the functions of the internal bits of i.e. TCR - TIM0 are the same as for TCR - TIM1).

Table 13-5. Multifunction Timer Register Map (Group F)

Applicable to ST902x			
	Page 10 Page 0Ah	Page 9 Page 09h	
R255	IMDR - TIM0		FFh
R254	FLAGR - TIM0		FEh
R253	OBCR - TIM0		FDh
R252	OACR - TIM0		FCCh
R251	PRSR - TIM0		FBh
R250	ICR - TIM0		FAh
R249	TMR - TIM0		F9h
R248	TCR - TIM0	IOCR	F8h
R247	CMP1LR - TIM0		F7h
R246	CMP1HR - TIM0		F6h
R245	CMP0LR - TIM0		F5h
R244	CMP0HR - TIM0		F4h
R243	REG1LR - TIM0	IDCR - TIM0	F3h
R242	REG1HR - TIM0	IVR - TIM0	F2h
R241	REG0LR - TIM0	DAPR - TIM0	F1h
R240	REG0HR - TIM0	DCPR - TIM0	F0h

REGISTER DESCRIPTION (Continued)

13.7.1 Register 0 (REG0R) Registers

This pair of registers (REG0LR and REG0HR) is used to capture values from the U/D counter or to load preset values into the U/D counter.

REG0HR R240 (F0h) Read/Write
Capture Load Register 0 (High)

Reset value: undefined

							7								0
R15	R14	R13	R12	R11	R10	R9	R8								

REG0LR R241 (F1h) Read/Write
Capture Load Register 0 (Low)

Reset value: undefined

							7								0
R7	R6	R5	R4	R3	R2	R1	R0								

13.7.2 Register 1 (REG1R) Registers

This pair of registers (REG1LR and REG1HR) is used (as REG0R) to capture values from the U/D counter or to load preset values into the U/D counter.

REG1HR R242 (F2h) Read/Write
Capture Load Register 1 (High)

Reset value: undefined

							7								0
R15	R14	R13	R12	R11	R10	R9	R8								

REG1LR R243 (F3h) Read/Write
Capture Load Register 1 (Low)

Reset value: undefined

							7								0
R7	R6	R5	R4	R3	R2	R1	R0								

13.7.3 Compare 0 (CMP0R) Registers

This pair of Registers (CMP0L and CMP0H) is used to store 16-bit values to be compared to the U/D counter content.

CMP0HR R244 (F4h) Read/Write
Compare 0 Register (High)

Reset value: undefined

							7								0
R15	R14	R13	R12	R11	R10	R9	R8								

CMP0LR R245 (F5h) Read/Write
Compare 0 Register (Low)

Reset value: undefined

							7								0
R7	R6	R5	R4	R3	R2	R1	R0								

13.7.4 Compare 1 (CMP1R) Registers

This pair of Registers (CMP1L and CMP1H) is used (as CMP0R) to store 16-bit values to be compared to the U/D counter content.

CMP1HR R246 (F6h) Read/Write
Compare 1 Register (High)

Reset value: undefined

							7								0
R15	R14	R13	R12	R11	R10	R9	R8								

CMP1LR R247 (F7h) Read/Write
Compare 1 Register (Low)

Reset value: undefined

							7								0
R7	R6	R5	R4	R3	R2	R1	R0								

ST9 - Multifunction Timer (ST902x)

REGISTER DESCRIPTION (Continued)

13.7.5 Timer Control Register (TCR)

This register is used to control the status of the timer.

TCR R248 (F8h) Read/Write
Timer Control Register

Reset value: 0000 0xxx

7							0
CEN	CCP0	CCMP0	CCL	UDC	UDCS	OF0	CS

b7 = **CEN**: *Counter Enable*. This bit is ANDed with the Global Counter Enable bit (GCEN bit on R230 - Central Interrupt Control Register; the GCEN bit is set after the Reset cycle). Setting the CEN bit starts the counter and prescaler (without reload). When this bit is reset, the counter and prescaler stop.

b6 = **CCP0**: *Clear on Capture*. When this bit is set, a clear of the counter and a reload of the prescaler are performed on REG0R or REG1R capture. No effect when this bit is reset.

b5 = **CCMP0**: *Clear on Compare*. When this bit is set, a clear of the counter and a reload of the prescaler are performed on CMP0R compare. No effect when this bit is reset.

b4 = **CCL**: *Counter clear*. When this bit is set, the counter is cleared without generation of interrupt request. No effect when this bit is reset.

b3 = **UDC**: *Software Up/Down*. When the direction of the counter is not fixed by TxINA and/or TxINB (see par. 10.3) it can be software controlled by the UDC bit. Setting the UDC bit selects the Up mode counting. Resetting this bit the Down counting is performed.

b2 = **UDCS**: *Up/Down Count status*. This bit is read only and monitors the direction of the counter. Reading "1" means that the counter is using the Up mode counting. Reading "0" means that the Down mode counting is in use.

b1 = **OF0**: *OVF/UNF state*. This bit is read only and is set if an Overflow or an Underflow occurs during a Capture on Register 0.

b0 = **CS**: *Counter Status*. This bit is read only and monitors the status of the counter. Reading "1" means that the counter is running. Reading "0" indicates that the counter is halted.

13.7.6 Timer Mode Register (TMR)

This register is used to select the operating mode of the timer.

TMR R249 (F9h) Read/Write
Timer Mode Register

Reset value: 0000 0000b (00h)

7							0
OE1	OE0	BM	RM1	RM0	ECK	REN	CO

b7 = **OE1**: *Output 1 Enable*. Setting this bit enables the Output 1 (TxOUTB) of the relevant timer. When this bit is reset, the TxOUTB is disabled and forced to the logic state "1". The relevant I/O bit must also be set to Alternate Function.

b6 = **OE0**: *Output 0 Enable*. Setting this bit enables the Output 0 (TxOUTA) of the relevant timer. When this bit is reset, the TxOUTA is disabled and forced to the logic state "1". The relevant I/O bit must also be set to Alternate Function.

b5 = **BM**: *Bivalue Mode*. This bit enables the Bivalue mode when is set. When the bit is reset, the Bivalue mode is disabled. After that, depending on the value of RM0 bit (TMR - bit 3), the Biload or Bicapture mode is selected.

b4 = **RM1**: *REG1R mode*. When this bit is set, the REG1R can be used to capture the value of the counter. When the bit is reset, the REG1R monitors the value of the counter. The selection performed by this bit has no effect when the Bivalue Mode is enabled.

b3 = **RM0**: *REG0R mode*. When this bit is set, the REG0R can be used to capture the value of the counter (also the Bicapture mode can be selected if the BM bit is equal to 1). When the bit is reset, the REG0R can be used to load the new value of the counter (also the Biload mode can be selected if the BM bit is equal to "1").

b2 = **ECK**: *Timer clocking mode*. This bit selects the clock source which drives the prescaler. When the ECK bit is reset, either the Internal or External clock is used depending on IN0 - IN3 configuration in ICR. When ECK bit is set, different functions are performed depending on the number of the relevant timer. For odd timers (Timer 1, Timer 3 and so on) setting the ECK bit enables the Parallel mode where the prescaler of the odd timer is driven by the prescaler output of the even timer.

REGISTER DESCRIPTION (Continued)

b1 = **REN**: *Retrigger mode*. When this bit is reset, the Retriggerable mode is enabled. When the bit is set, this operating mode is disabled.

b0 = **CO**: *Continuous/One shot mode*. When this bit is reset, the Continuous mode is selected (with autoreload on condition). The bit must be set to select the one shot mode. The following table summarizes the different operating modes depending on the values of RM0, RM1 and BM bits.

Table 13-6. Timer Operating Modes

TMR Bits			Timer Operating Modes
BM	RM1	RM0	
1	X	0	Biload mode
1	X	1	Bicapture mode
0	0	0	Load from REG0R and Monitor on REG1R
0	1	0	Load from REG0R and Capture on REG1R
0	0	1	Capture on REG0R and Monitor on REG1R
0	1	1	Capture on REG0R and REG1R

13.7.7 External Input Control Register(ICR)

By this register it is possible to program the function and the operation to be performed on TxINA and TxINB inputs.

ICR R250 (FAh) Read/Write
External Input Control Register
Reset value: 0000 xxxxb (0Xh)

7							0
IN3	IN2	IN1	IN0	A0	A1	B0	B1

b7-b4 = **IN3,IN2,IN1,IN0**: *Input pin assignment*. The different functions of TxINA and TxINB inputs of every timer can be selected by IN0 - IN3 bits as explained below.

b3-b2 = **A0, A1**: *TxINA event programming*. The following TxINA configurations can be selected according to the values of A0 and A1 bits:

b1-b0 = **B0, B1**: *TxINB event programming*. The following TxINB configurations can be selected according to the values of B0 and B1 bits:

A0/B0	A1/B1	TxINA/TxINB Configuration
0	0	No operation
0	1	Falling edge sensitive
1	0	Rising edge sensitive
1	1	Rising and falling edges

I C Reg. IN3-IN0 bits	TxINA Input Function	TxINB Input Function
0000	not used	not used
0001	not used	Trigger
0010	Gate	not used
0011	Gate	Trigger
0100	not used	Ext. Clock
0101	Trigger	not used
0110	Gate	Ext. Clock
0111	Trigger	Trigger
1000	Clock Up	Clock Down
1001	Up/Down	Ext. Clock
1010	Trigger Up	Trigger Down
1011	Up/Down	not used
1100	Autodiscr.	Autodiscr.
1101	Trigger	Ext. Clock
1110	Ext. Clock	Trigger
1111	Trigger	Gate

ST9 - Multifunction Timer (ST902x)

REGISTER DESCRIPTION (Continued)

13.7.8 Prescaler Register (PRSR)

This register holds the preset value for the 8-bit prescaler. The PRSR content may be modified at any time, but it will be loaded into the prescaler at the following prescaler underflow, or as a consequence of a counter reload (either by software or upon external request). On an external RESET condition, the prescaler is automatically loaded with the 00h value, so that the prescaler divides by 1 and the maximum counter clock is generated (OSCIN frequency divided by 6 when MODER.5 = DIV2 bit is set).

PRSR R251 (FBh) Read/Write
Prescaler Register

Reset value: 0000 0000b (00h)

7							0
P7	P6	P5	P4	P3	P2	P1	P0

The binary value stored (by programmer) in the PRSR register is equal to [divider value - 1]. For example, loading PRSR with 24 makes the prescaler divide by 25.

13.7.9 Output A Control Register (OACR)

This register selects the sources that can perform actions on a TxOUTA pin. TxOUTA can be driven from any of three possible sources:

- OVF/UNF being an Overflow or Underflow event on the U/D counter,
- COMP0 being a successful compare event on CMP0R register, and
- COMP1 being a successful compare event on CMP1R.

By programming bits B0 and B1 of the relevant source can cause one of the following four effects on TxOUTA (which can be preset previously):

B0	B1	Event
0	0	Set
0	1	Toggle
1	0	Reset
1	1	Nop

Note: In any case of contemporary events the action will be taken which results from 'ANDing' the B1-B0 fields. Through this register the action of COMP0 on the on-chip event can be also selected.

OACR R252 (FCh) Read/Write
Output A Control Register

Reset value: xxxx xx0xb

7							0
B0	B1	B0	B1	B0	B1	CEV	OP

< COMP0 > < COMP1 > < OVF/UNF >

b7-b6 = **B0, B1**: Control bits of COMP0. Control bits for event driven by COMP0.

b5-b4 = **B0, B1**: Control bits of COMP1. Control bits for event driven by COMP1.

b3-b2 = **B0, B1**: Control bits of OVF/UNF. Control bits for event driven by OVF/UNF.

b1 = **CEV**: On-Chip Event on CMP0R. When this bit is set, a successful compare on CMP0R activates the on-chip event signal (a single pulse is generated). No action when this bit is reset.

b0 = **OP**: Control bit of TxOUTA preset. The value of this bit is the preset value of TxOUTA output pin. Reading this bit returns the current state of the TxOUTA output pin (i.e. useful when this output is selected in toggle mode).

REGISTER DESCRIPTION (Continued)

13.7.10 Output B Control Register (OBCR)

This register selects the sources that can perform actions on TxOUTB output pin. TxOUTB can be driven from any of three possible sources:

- OVF/UNF being an Overflow or Underflow event on the U/D counter,
- COMP0 being a successful compare event on CMP0R register, and
- COMP1 being a successful compare event on CMP1R.

By programming bits B0 and B1 of the relevant source can cause one of the following four effects on TxOUTB (which can be previously preset):

B0	B1	Event
0	0	Set
0	1	Toggle
1	0	Reset
1	1	Nop

Note: In any case of contemporary events the action will be taken which results from 'ANDing' the B1-B0 fields. Through this register the action of Overflow/Underflow on the on-chip event can be also selected.

OBCR R253 (FDh) Read/Write
Output B Control Register

Reset value: xxxx xx0xb

7 0

B0	B1	B0	B1	B0	B1	OEV	OP
----	----	----	----	----	----	-----	----

< COMP0 > < COMP1 > < OVF/UNF >

b7-b6 = **B0, B1**: control bits of COMP0. Control bits for event driven by COMP0.

b5-b4 = **B0, B1**: control bits of COMP1. Control bits for event driven by COMP1.

b3-b2 = **B0, B1**: control bits of OVF/UNF. Control bits for event driven by OVF/UNF.

b1 = **OEV**: On-Chip Event on OVF/UNF. When this bit is set, a successful Overflow/Underflow activates the on-chip event signal (a single pulse is generated). No action when this bit is reset.

b0 = **OP**: control bit of TxOUTB preset. The value of this bit is the preset value of TxOUTB output pin. Reading this bit, it returns the current state of the TxOUTB output pin (i.e. useful when this output is selected in toggle mode).

13.7.11 Flag Register (FLAGR)

This register contains the flags of the successful captures or comparisons together with the Overflow/Underflow and overrunning indications. Also the mode of the Interrupt on capture can be selected. By writing into the capture flags it is possible to generate software captures. It is necessary to clear the capture flag before subsequent software captures can be generated. By reading this register, user can know which source has generated an interrupt (several sources may share the same interrupt vector).

FLAGR R254 (FEh) Read/Write
Flags Register

Reset value: 0000 0000b (00h)

7 0

CP0	CP1	CM0	CM1	OUF	OCP0	OCM0	A0
-----	-----	-----	-----	-----	------	------	----

b7 = **CP0**: Flag on Capture 0. This bit is set after a capture on REG0R register. Writing "1" acts as a software load/capture from/on REG0R.

b6 = **CP1**: Flag on Capture 1. This bit is set after a capture on REG1R register. Writing "1" acts as a software capture on REG1R, except when in Bi-capture mode.

b5 = **CM0**: Flag on Compare 0. This bit is set after a successful compare on CMP0R register.

b4 = **CM1**: Flag on Compare 1. This bit is set after a successful compare on CMP1R register.

b3 = **OUF**: Flag on Overflow/Underflow. This bit is set after a counter Over/Underflow condition.

b2 = **OCP0**: Flag of overrun on Capture 0. This bit is set when more than one INT/DMA request occurs before having reset the event flag CP0 or whenever a capture is software simulated.

b1 = **OCM0**: Flag of overrun on Compare 0. This bit is set when more than one INT/DMA request occurs before having reset the event flag CM0.

b0 = **A0**: Capture Interrupt Function. When this bit is set the Interrupt is generated by an AND function of REG0R/REG1R captures while when the A0 bit is reset, the Interrupt is generated by an OR function of REG0R/REG1R captures.

ST9 - Multifunction Timer (ST902x)

REGISTER DESCRIPTION (Continued)

13.7.12 Interrupt/DMA Mask Register (IDMR)

This register contains the Global Timer Interrupt enable bit and the INT/DMA enable bits of the following events:

- Capture on REG0R (CP0 field),
- Capture on REG1R (CP1I bit - only Interrupt mask),
- Compare on CMP0R (CM0 field),
- Compare on CMP1R (CM1I bit- only Interrupt mask), and
- Overflow/Underflow (OUI bit - only Interrupt mask).

IDMR R255 (FFh) Read/Write
Interrupt/DMA Mask Register

Reset value: 0000 0000b (00h)

7							0
GTIEN	CP0D	CP0I	CP1I	CM0D	CM0I	CM1I	OUI
< CP0 >>CP1>< CM0 >>CM1>							

b7 = **GTIEN**: *Global Timer Interrupt Enable*. When this bit is set, all the Interrupts (of the enabled sources) of the timer are enabled. When the bit is reset, all the Interrupts of timer are disabled.

b6 = **CP0D**: *Capture 0 DMA Mask*. Capture on REG0R DMA is enabled when CP0D = "1".

b5 = **CP0I**: *Capture 0 Interrupt Mask*. Capture on REG0R interrupt is enabled when CP0I = "1".

b4 = **CP1I**: *Capture 1 Interrupt Mask*. Capture on REG1R interrupt is enabled when CP1I = "1".

b3 = **CM0D**: *Compare 0 DMA Mask*. Compare on CMP0R DMA is enabled when CM0D = "1".

b3 = **CM0I**: *Compare 0 Interrupt Mask*. Compare on CMP0R interrupt is enabled when CM0I = "1".

b1 = **CM1I**: *Compare 1 Interrupt Mask*. Compare on CMP1R interrupt is enabled when CM1I = "1".

b0 = **OUI**: *Overflow/Underflow Interrupt Mask*. Overflow/Underflow condition interrupt is enabled when OUI = "1".

Note. The following Registers show in square brackets ([]) the Register address in the case of an odd numbered (1, 3, 5...) Multifunction Timer being available on-chip. If only one Timer is present these addresses may be ignored.

13.7.13 DMA Counter Pointer Register (DCPR)

This register is not used only as DMA Counter pointer but also to define the DMA area and the DMA source.

DCPR R240 (F0h)[R244 (F4h)] Read/Write
DMA Counter Pointer Register

Reset value: undefined

7						0	
DCP7	DCP6	DCP5	DCP4	DCP3	DCP2	DMA SRCE	REG MEM

b7-b2 = **DCP7-DCP2**: *MSB of DMA counter register address*. Those bits contain the most significant bits of the DMA counter register address and are user programmable. Though user programmable, the D2 bit may be hardware toggled if the Swap mode is set for the Timer DMA section related to Compare 0 channel.

b1 = **DMA-SRCE**: *DMA source selection (hardware programmed)*. This bit is hardware fixed by the Timer DMA logic and is set if the DMA destination is a Compare on CMP0R register and reset if the DMA source is a Capture on REG0R register.

b0 = **REG/MEM**: *DMA area selection*. When this bit is set, it selects the Source/Destination of the DMA area from/into Register File while when it is reset, the Source/Destination of the DMA area is from/to the External Program or Data Memory (according with the value of D0 bit in DAPR).

REGISTER DESCRIPTION (Continued)

13.7.14 DMA Address Pointer Register (DAPR)

This register is not used only as DMA Address pointer but also to define the DMA area and the DMA source.

DAPR R241 (F1h)[R245 (F5h)] Read/Write DMA Address Pointer Register

Reset value: undefined

7							0
DAP7	DAP6	DAP5	DAP4	DAP3	DAP2	DMA SRCE	PRG/DAT

b7-b2 = **DAP7-DAP2**: *MSB of DMA Address register location*. Those bits contain the most significant bits of the DMA Address register location and are user programmable. Through user programmable, the bit D2 may be hardware toggled if the Swap mode is set for the Timer DMA section related to Capture 0 channel.

b1 = **DMA-SRCE**: *DMA source selection (hardware programmed)*. This bit is hardware fixed by the Timer DMA logic and is set if the DMA destination is a Compare on CMP0R register and reset if the DMA source is a Capture on REG0R register.

b0 = **PRG/DAT**: *DMA memory selection*. When this bit is set it selects the Source/Destination of the DMA area from/into Data Memory while when it is reset the Source/Destination of the DMA area is from/into the External Program Memory (according with the value of D0 bit in DCPR).

REG/MEM	PRG/DAT	DMA Source/Destination
0	0	Program memory
0	1	Data memory
1	0	Register file
1	1	Register file

13.7.15 Interrupt Vector Register (IVR)

This register is used as a vector pointing to the 16-bit interrupt vectors in the program memory which contain the starting addresses of the three interrupt subroutines managed by every timer.

Only one Interrupt Vector Register is available for every timer and is able to manage the three interrupt groups because the 3 least significant bits are fixed by hardware depending on the group which generated the interrupt request.

In order to understand which request generated the interrupt inside the same group, the FLAGR register can be used to check the relevant flag of the interrupt source.

IVR R242 (F2h) [R246 (F6h)] Read/Write Interrupt Vector Register

Reset value: xxxx xxx0b

7							0
V4	V3	V2	V1	V0	W1	W0	D0

b7-b3 = **V4 - V0**: *MSB of the Vector address*. These bits are user programmable and contain the five most significant bits of the Timer interrupt vector addresses in the program memory. In any case, an 8-bit address can be used to indicate the Timer interrupt vector locations because they are within the first 256 locations of the program memory (see Interrupt and DMA chapters).

b2-b1 = **W1 - W0**: *Vector Address bits*. These bits are equivalent to bit 1 and bit 2 of the Timer interrupt vector addresses in the program memory. They are fixed by hardware depending on the group of sources which generated the interrupt request as follows:

b0 = **D0**. This bit is fixed by hardware. It always returns the value "0" if read.

W1	W0	Interrupt Source
0	0	Overflow/Underflow even interrupts
0	1	Not available
1	0	Capture event interrupts
1	1	Compare event interrupts

ST9 - Multifunction Timer (ST902x)

REGISTER DESCRIPTION (Continued)

13.7.16 Interrupt/DMA Control Register (IDCR)

This register is used to control the Interrupt and DMA priority level, the DMA transfer source and destination and the Swap mode. This register contains also the two End Of Block bits.

IDCR R243 (F3h) [R247 (F7h)] Read/Write
Interrupt/DMA Control Register
Reset value: 1100 0111b (C7h)

7							0
CPE	CME	DCTS	DCTD	SWEN	PL2	PL1	PL0

b7 = **CPE**: *Capture 0 EOB*. This bit is set by hardware when the End Of Block condition is reached during a Capture 0 DMA operation with the Swap mode enabled. When the Swap mode is disabled (SWEN bit = "0") the CPE bit is forced by hardware to "1".

b6 = **CME**: *Compare 0 EOB*. This bit is set by hardware when the End Of Block condition is reached during a Compare 0 DMA operation with the Swap mode enabled. When the Swap mode is disabled (SWEN bit = "0") the CME bit is forced by hardware to "1".

b5 = **DCTS**: *DMA Capture Transfer Source*. This bit selects the source of the DMA operation related to the channel associated to the Capture 0. When the DCTS bit is reset the selected source is the REG0R register. When the DCTS bit is set the ST9 port is selected as DMA transfer source (with this DMA channel the ST9 port can also be destination depending on the value of the DD bit in the HDCTL register of the port - see I/O port chapter 9).

b4 = **DCTD**: *DMA Compare Transfer Destination*. This bit selects the destination of the DMA operation related to the channel associated to the Compare 0. When this bit is reset, the selected destination is the CMP0R register. When the bit is set, the ST9 port is selected as DMA transfer destination.

b3 = **SWEN**: *Swap function Enable*. When this bit is set, the Swap function is enabled for the two DMA channels. Resetting the SWEN bit disables the Swap mode.

b2-b0 = **PL2 to PL0**: *Interrupt/DMA priority level*. With these three bits it is possible to select the Interrupt and DMA priority level of every single timer within eight different levels (see Interrupt/DMA chapter).

13.7.17 I/O Connection Register (IOCR)

This register allows user to select (or not) an on-chip connection between input A and output A of one same timer.

IOCR R248 (F8h) Read/Write
I/O Connection Register
Reset value: 1111 1100b (FCh)

7							0
						SC1	SC0

b7-b2 = not used.

b1 = **SC1**: *Select Connection Odd*. SC1 selects if connection between TxOUTA and TxINA for ODD timers is made on-chip or externally (physically on pins)

SC1 = "0": TxOUTA and TxINA unconnected

SC1 = "1": TxOUTA and TxINA connected internally

b0 = **SC0**: *Select Connection Even*. SC0 selects if connection between TxOUTA and TxINA for EVEN timers is made on-chip or externally (physically on pins)

SC0="0": TxOUTA and TxINA unconnected

SC0="1": TxOUTA and TxINA connected internally

14 SERIAL COMMUNICATIONS INTERFACE

14.1 INTRODUCTION

The ST9 Serial Communications Interface (SCI) offers a means of full-duplex serial data transfer to a wide range of external equipments.

The SCI has the following features:

- Full duplex character-oriented synchronous and asynchronous operation
- Synchronous serial port expansion capability
- Transmit, receive, line status, and device address interrupt generation
- Integral Baud Rate Generator capable of dividing the input clock by any value from 2 to $2^{16}-1$ (16 bit word) and generating the internal 16X clock for asynchronous operation or 1X clock for synchronous operation
- Fully programmable serial-interface characteristics:
 - 5, 6, 7, or 8 bit word length
 - Even, odd, or no parity generation and detection
 - 1, 1-1/2, 2, 2-1/2 stop bit generation
 - False start bit detection
 - Complete status reporting capabilities
 - Line break generation and detection
- Programmable address indication bit (wake-up bit) and User invisible compare logic to support network communication of multiple microcomputers. Optional character search function.
- Internal diagnostic capabilities:
 - Local loopback for communications link fault isolation
 - Auto-echo for communications link fault isolation
- Separate interrupt/DMA channels for both transmit and receive

Figure 14-1. SCI Block Diagram

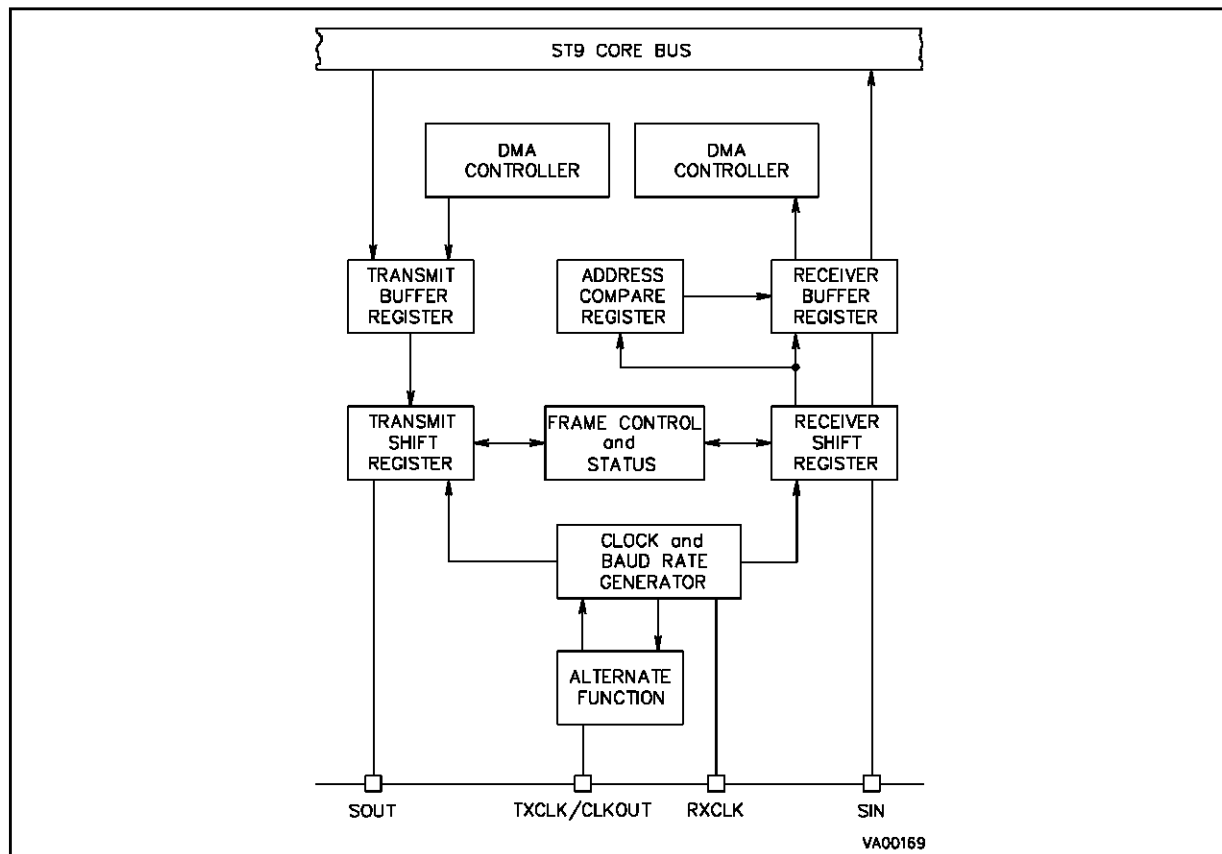

ST9 - Serial Communication Interface (ST902x)

14.2 FUNCTIONAL DESCRIPTION

SCI can run in three operational modes:

- Asynchronous mode
- Synchronous mode
- Serial expansion mode

Each of these three modes output data with the same serial frame format. The differences are derived from the clock rate (1X, 16X) and the sampling clock (for the serial expansion mode).

Asynchronous Mode

In this mode, data and clock can be asynchronous (the emitter and receiver can have their own clock to sample received data), each data bit is sampled 16 times per clock period. Thus the baud rate clock should be set to the $\div 16$ Mode and the frequency of the clock input (from an external source or the internal baud-rate generator output) set to suit this.

Synchronous Mode

In this mode, data and clock are synchronous, each data bit is sampled once per clock period.

Serial Expansion Mode

This mode is used to access to an external synchronous peripheral.

The transmitter will provide the clock waveform only during the period that data is being transmitted through CLKOUT pin (the Data Envelope). The data is latched on the rising edge of this clock.

Whenever the SCI is to receive data in the serial port expansion mode, the clock waveform must be supplied externally, synchronous with the data to the ST9. The SCI will latch the incoming data on the rising edge of the receiver I/O expansion clock. The clock input is supplied on pin RXCLK.

Figure 14-3. Asynchronous mode

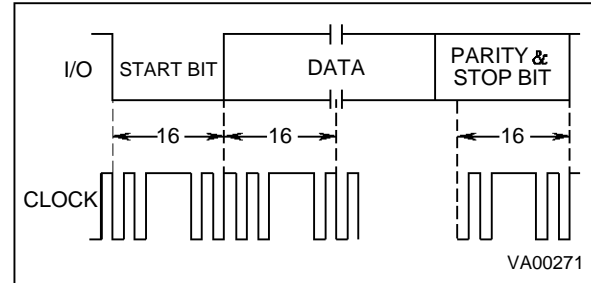

Figure 14-4. Synchronous Mode

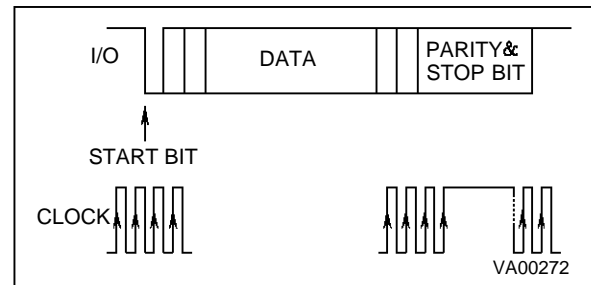

Figure 14-5. Serial Expansion Mode

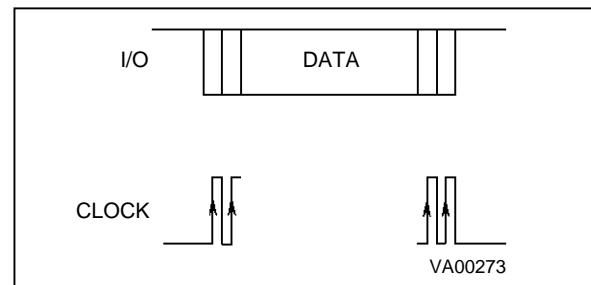
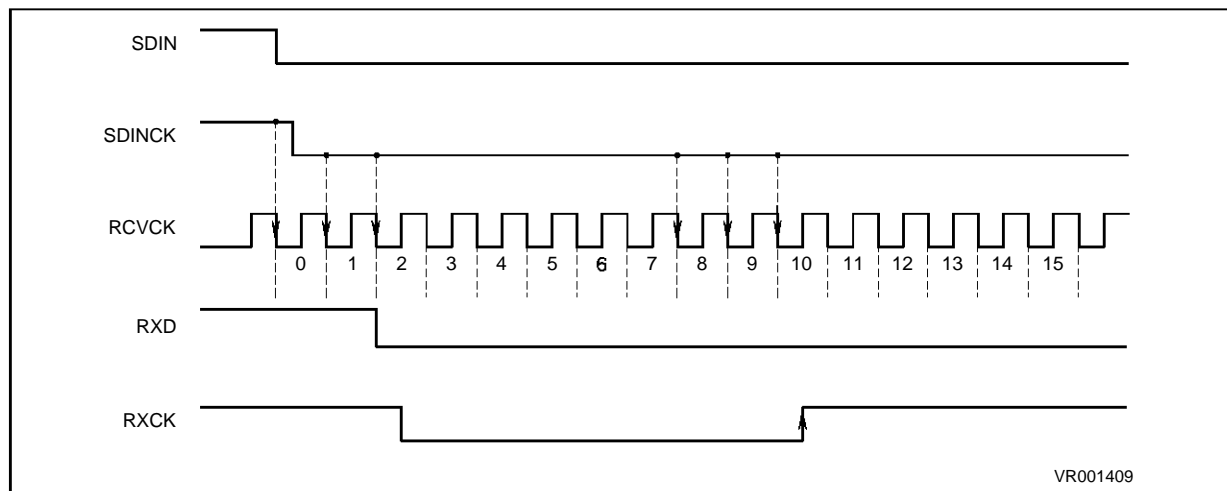

Figure 14-2. Sampling Times in Asynchronous Format



FUNCTIONAL DESCRIPTION (Continued)

14.2.1 Serial Frame Format

Every character sent (or received) by the SCI has the following format:

This format is used by the SCI in all modes:

START: the start bit indicates the beginning of a data frame in the asynchronous mode. START bit is detected as a high to low transition

DATA: the DATA word is programmable to be from 5 to 8 bits long for both synchronous and asynchronous modes

PARITY: The Parity Bit is optional, and can be used with any length of word. It is used for error checking and resets in a resultant state (odd or even) depending on number of "1"s in DATA.

ADDRESS/9TH: The Address/9th Bit is optional and may be added to any word format. It is used in both synchronous or asynchronous mode to indicate that the data is an address (bit = "1").

The ADDRESS/9TH bit is useful when several microcontrollers are exchanging data on the same serial bus. Individual microcontrollers can stay idle on the serial bus, waiting for a transmitted address. When a microcontroller recognizes its own address, it can begin Data Reception, likewise, on the transmit side, the microcontroller can transmit another address to begin communication with a different microcontroller.

The ADDRESS/9TH bit can be used as an additional data bit or to mark control words (9th bit).

STOP: Indicates the end of a data frame for both asynchronous and synchronous modes. The stop bit is programmed to be 1, 1.5, 2, or 2.5 bits long. It returns the SCI to the quiescent marking state (i.e., a constant high-state condition) which lasts until a new start bit indicates an incoming word.

Data transfer

Data to be transmitted by the SCI is first loaded by the program into the Transmitter Buffer Register. The SCI will transfer the data into the Transmitter Shift Register when the Shift Register becomes available (empty). The Transmitter Shift Register converts the parallel data into the serial format for transmission through the SCI Alternate Function output, Serial Data Out. After the completion of the transfer, the transmitter buffer register interrupt pending bit will be updated.

If the selected word format is less than 8 bits, the unused most significant bits are "don't care".

Incoming serial data from the Serial Data Input pin is converted into parallel data for reception in the Receiver Shift Register. At the end of the input, the data portion of the received word is transferred from the Receiver Shift Register into the Receiver Buffer Register. All Receiver interrupt conditions are updated at the time of transfer.

If the selected character format is less than 8 bits, the unused most significant bits will have the value "1".

The Frame Control and Status block creates and checks the character configuration (Data length and stop bits), and the source for the transmitter/receiver clock.

The integral Baud Rate Generator contains a programmable divide by "N" counter which can be used to generate the clocks for the transmitter and/or receiver. The baud rate generator can use INTCLK or the Receiver clock input RXCLK.

The Address bit/D9 is optional and may be added to any word format. It is commonly used in network or machine control applications. When enabled (AB, CHCR.4 = "1"), an address or ninth data bit can be added to a transmitted word by setting the

Figure 14-6. SCI Character Format

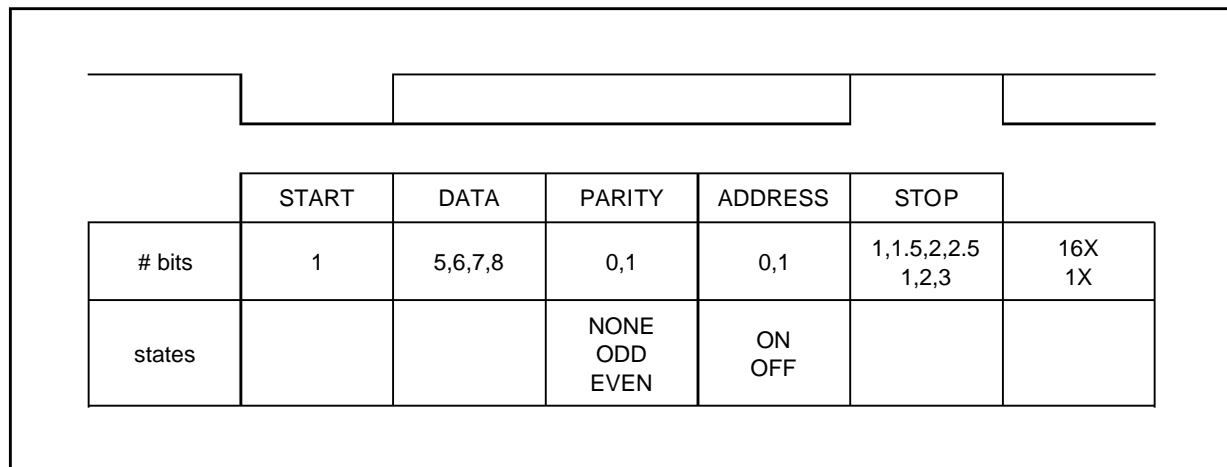

ST9 - Serial Communication Interface (ST902x)

FUNCTIONAL DESCRIPTION (Continued)

Set Address bit (SA, IDPR.5). This is then appended to the next word entered into the (empty) Transmitter Buffer Register and then cleared by hardware.

On character input an Address Bit set can indicate that the data preceding the bit is an address which may be compared in hardware with the value in the Address Compare Register (ACR) to generate an Address Match interrupt when equal.

The Address bit and Address Comparison Register can also be combined to generate an Address Interrupt in 4 modes to suit different protocols, based upon the status of the Address Mode Enable bit (AMEN, IDPR.7) and the Address Mode bit (AM, CHCR.7).

Table 14-1. Address Interrupt Modes

If 9th Data Bit = 1
If Character Match
If Character Match and 9th Data Bit = 1
If Character Match on Word Immediately Following Break

The character match Address Interrupt mode may be used as a powerful character search mode, giving an interrupt on reception of a predetermined character e.g. Carriage Return or End of Block codes.

The Line Break condition is fully supported for both transmission and detection. Line Break is sent by setting the SET_BREAK bit (SB, IDPR.6). This causes the transmitter output to be held low (after all buffered data has been transmitted) for a minimum of one complete word length and until the SB bit is Reset.

Testing of the communications channel may be performed using the facilities of the SCI. Auto Echo mode (SCI SOUT disconnected, SIN pin internally connected to SOUT pin) and Loopback mode (SCI transmitter and receiver sections disconnected from SOUT and SIN pins and directly connected internally) may be used individually or together.

Figure 14-7. Auto Echo Configuration

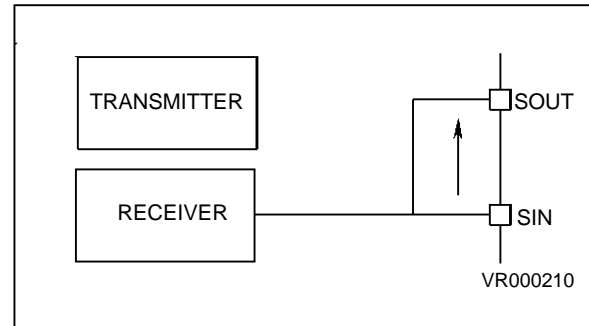

Figure 14-8. Loop Back Configuration

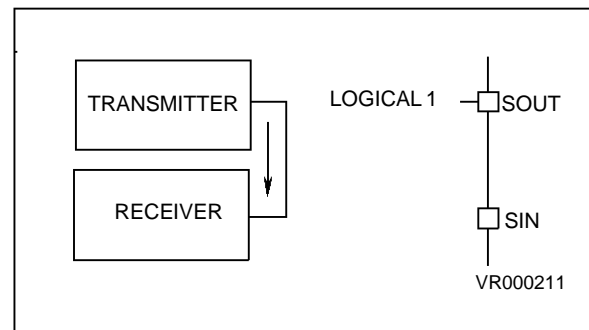
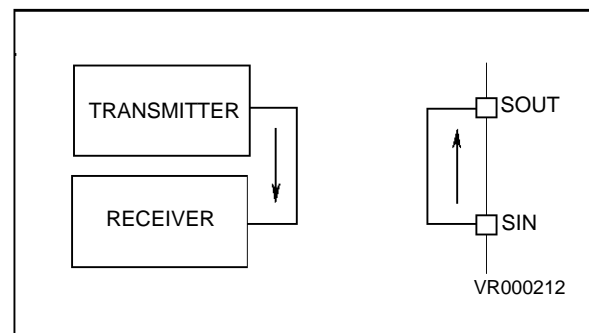

Figure 14-9. Auto Echo and Loop Back Config.



FUNCTIONAL DESCRIPTION (Continued)

14.2.2 Clocks And Serial Transmission Rates

The communication bit frequency of the SCI transmitter and receiver sections can be provided from the integral Baud Rate Generator (allowing a maximum asynchronous bit rate of 350k Baud) or from external sources (maximum bit rate 175k Baud). This clock is divided by 16 for asynchronous mode (CD, CCR.3, = "0"), or divided by 1 for synchronous modes (CD = "1").

External Clock Sources. The External Clock input pin TXCLK may be programmed by bits TXCLK (CCR.7) and OCLK (CCR.6) to be: the transmit clock input (respecting the ± 16 and ± 1 timing requirements), to act as the output of the Baud Rate Generator (allowing an external divider circuit to provide the receive clock for split rate transmit and receive e.g. 1200/75 baud), or to be CLKOUT, the clock output for the synchronous mode.

The Receive clock input via RXCLK input function is enabled by the XR bit CCR.5, this input should be set according to the setting of the CD bit.

Baud Rate Generator. The integral Baud Rate Generator is a 16-bit programmable divide by "N" counter which can be used to generate the clocks for the transmitter and/or receiver. The minimum baud rate divisor is 2 and the maximum divisor is $2^{16}-1$. After initialization of the baud rate generator, the divisor value is immediately loaded into the counter. This prevents potentially long random counts on the initial load.

Baud Rate generator frequency = Input Clock frequency/Divisor

WARNING. Programming the baud rate division to 0 or 1 will stop the divisor.

The output of the baud generator has an exact 50% duty cycle. The output can provide either the 16X clock for asynchronous operation or a 1X clock for synchronous and serial port expansion modes for the receiver and the transmitter. An additional divide by 16 may be appropriate to compute the SCI data rate if in this normal operating mode.

The Baud Rate generator can use INTCLK for the input clock source. In this case, INTCLK should be chosen to provide a suitable frequency for division

by the Baud Rate Generator to give the required transmit and receive bit rates.

Suitable INTCLK frequencies and the divider values for standard Baud rates are shown in Table 14-2.

Notes:

1) Writing to a Baud Rate Generator Register immediately disables and resets both the SCI baud rate generator, the transmitter and receiver circuitry. After writing to the remaining Baud Rate Generator Register, the transmitter and receiver circuits are enabled. The Baud Rate generator will load the new value and start counting.

Thus to initialize the SCI, the user should first initialize one Baud Rate Generator Divisor Register. This will reset all SCI circuitry. Initialize all other SCI registers for the desired operating mode, and then, to enable the SCI, initialize the remaining Baud Rate Generator Register.

2) For synchronous receive operation, the data and receive clock must not have significant skew between clock and data. The received data and clock are internally synchronized to INTCLK clock.

For synchronous transmit operation, a general purpose I/O port pin must be programmed to output the CLKOUT signal from the baud rate generator. If the SCI is provided with an external transmission clock source, there will be a skew equivalent to two INTCLK periods between clock and data.

The synchronous data will be transmitted on the fall of the transmit clock. The synchronous received data will be latched into the SCI on the rising edge of the provided receive clock.

The maximum data transfer rate is in synchronous mode (1x mode):

- Maximum bit rate = $\text{INTCLK}/8 = 12\text{MHz}/8 = 1.5 \text{ Mbit/s}$
- Maximum byte rate = $1.5 \text{ Mbit}/10 = 150 \text{ Kbytes/s}$

(one byte = 8 bits of data + 1 stop bit + 1 start bit = 10 bits)

ST9 - Serial Communication Interface (ST902x)

FUNCTIONAL DESCRIPTION (Continued)

Table 14-2. SCI Baud Rate Generator Divider Values

INTCLK: 7680.000 KHz							
Baud Rate	Clock Factor	Desired Freq (kHz)	Divisor		Actual Baud Rate	Actual Freq (kHz)	Deviation
			Dec	Hex			
50.00	16 X	0.80000	9600	2580	50.00	0.80000	0.0000%
75.00	16 X	1.20000	6400	1900	75.00	1.20000	0.0000%
110.00	16 X	1.76000	4364	110C	109.99	1.75985	0.0083%
300.00	16 X	4.80000	1600	0640	300.00	4.80000	0.0000%
600.00	16 X	9.60000	800	0320	600.00	9.60000	0.0000%
1200.00	16 X	19.20000	400	0190	1200.00	19.20000	0.0000%
2400.00	16 X	38.40000	200	00C8	2400.00	38.40000	0.0000%
4800.00	16 X	76.80000	100	0064	4800.00	76.80000	0.0000%
9600.00	16 X	153.60000	50	0032	9600.00	153.60000	0.0000%
19200.00	16 X	307.20000	25	0019	19200.00	307.20000	0.0000%
38400.00	16 X	614.40000	13	000D	36923.08	590.76923	3.8462%
76800.00	16 X	1228.80000	6	0006	80000.00	1280.00000	4.1667%
INTCLK: 11059.20 kHz							
Baud Rate	Clock Factor	Desired Freq (kHz)	Divisor		Actual Baud Rate	Actual Freq (kHz)	Deviation
			Dec	Hex			
50.00	16 X	0.80000	13824	3600	50.00	0.80000	0.0000%
75.00	16 X	1.20000	9216	2400	75.00	1.20000	0.0000%
110.00	16 X	1.76000	6284	188C	109.99	1.75990	0.0058%
300.00	16 X	4.80000	2304	0900	300.00	4.80000	0.0000%
600.00	16 X	9.60000	1152	0480	600.00	9.60000	0.0000%
1200.00	16 X	19.20000	576	0240	1200.00	19.20000	0.0000%
2400.00	16 X	38.40000	288	0120	2400.00	38.40000	0.0000%
4800.00	16 X	76.80000	144	0090	4800.00	76.80000	0.0000%
9600.00	16 X	153.60000	72	0048	9600.00	153.60000	0.0000%
19200.00	16 X	307.20000	36	0024	19200.00	307.20000	0.0000%
38400.00	16 X	614.40000	18	0012	38400.00	614.40000	0.0000%
76800.00	16 X	1228.80000	9	0009	76800.00	1228.80000	0.0000%

FUNCTIONAL DESCRIPTION (Continued)

14.2.3 Input Signals

SIN: Serial Data Input. This pin is the serial data input to the SCI receiver shift register.

TXCLK: External Transmitter Clock Input. This pin is the external input clock driving the SCI transmitter. The TXCLK frequency must be greater than or equal to 16 times the transmitter data rate (depending on the selection of X16 or X1 clock operating mode). The use of the TXCLK pin is optional.

RXCLK: External Receiver Clock Input. This input is the clock to the SCI receiver when using an external clock source to the SCI baud rate generator. INTCLK is normally the clock source. A 50/50 duty cycle is not required for this input, however, the short period must last more than two INTCLK periods. The use of the RXCLK pin is optional.

14.2.4 Output Signals

SOUT: Serial Data Output. This Alternate Function output signal is the serial data output from the SCI transmitter shift register.

CLKOUT: Clock Output. The Alternate Function of this pin outputs either the data clock from the transmitter to an external shift register in the serial expansion mode or the clock output from the Baud rate generator. In serial expansion mode it will clock only the data portion of the frame. The data is valid on the rising edge of the clock. The CLKOUT idle state is low.

14.3 INTERRUPTS AND DMA

14.3.1 Interrupts

The SCI is able to generate interrupts from multiple sources. Receive interrupts include data pending, receive errors (overrun, framing and parity), address or break pending. Transmit interrupts are software selectable for either the Transmit Holding Register Empty (HSN, IMR.7 = "1") or for the Transmit Shift Register Empty (HSN = "0").

Typical Usage of the Interrupts provided by the SCI is shown in Figure 14-10.

The SCI is able to generate interrupt requests on 10 events. Several of these events share the same interrupt vector, so it is necessary to poll ISR, the Interrupt Status Register, to determine the active trigger. These bits should be reset by the programmer during the Interrupt Service routine.

The four major levels of interrupt are encoded in hardware to provide two bits of the interrupt vector register, allowing the position of the block of pointer vectors to be resolved to a block size of 8 bytes.

Table 14-3. SCI Interrupt Vector

Interrupt Source	Vector Address
Transmitter Buffer or Shift Register Empty Transmit DMA end of Block	xxx x110
Received Ready Receive DMA end of Block	xxxx x100
Break Detector Address Word Match	xxxx x010
Receiver Error	xxxx x000

The SCI interrupts have an internal priority structure in order to resolve simultaneous events.

Table 14-4. SCI Interrupt Internal Priority

Receive DMA Request	Highest Priority
Transmit DMA Request	
Receive Interrupt	Lower Priority
Transmit Interrupt	

INTERRUPTS AND DMA (Continued)

Figure 14-10. SCI Interrupt Typical Usage

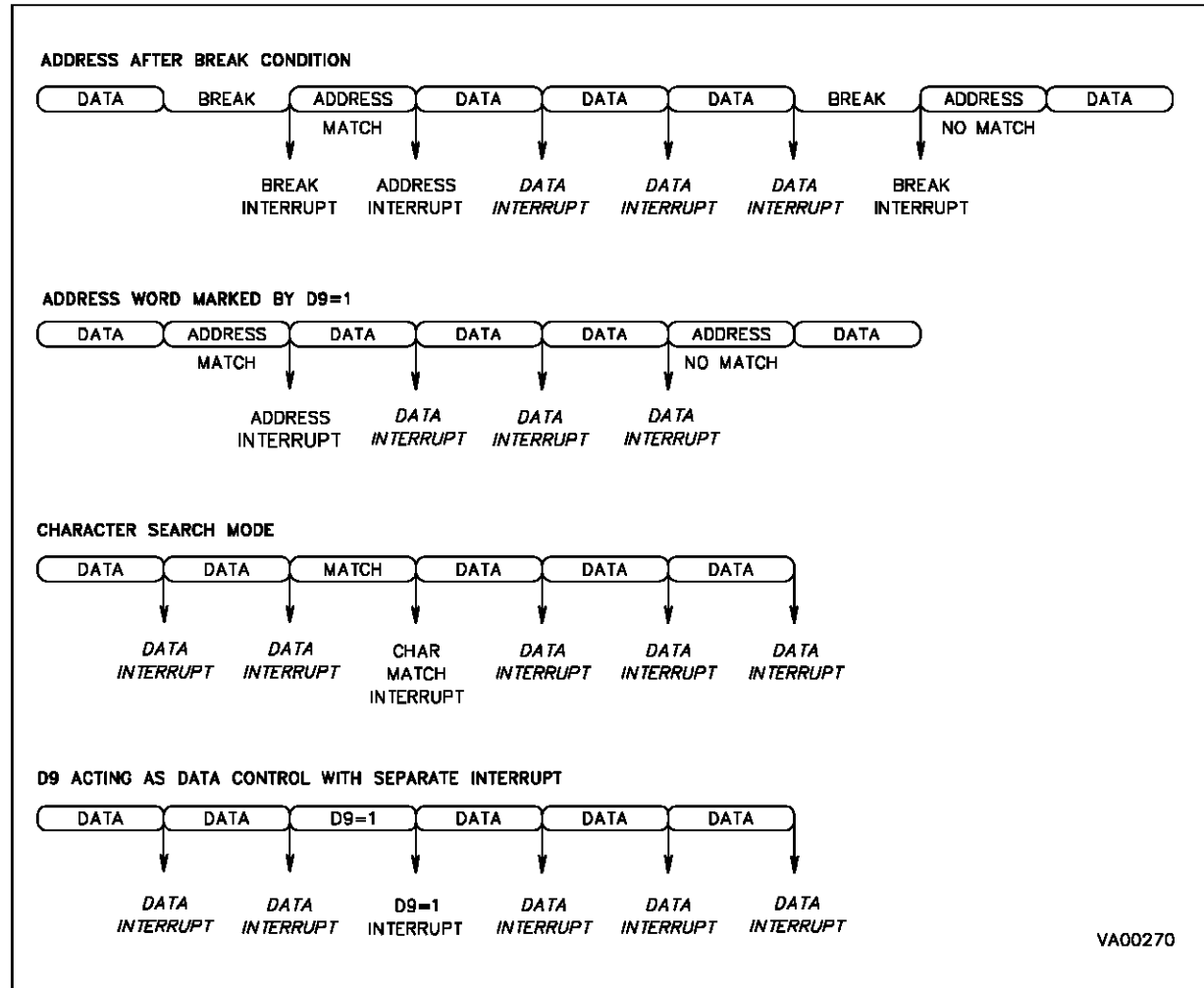

INTERRUPTS AND DMA (Continued)

14.3.2 DMA

Two DMA channels are associated with the SCI, for transmit and for receive. These follow the register scheme as described in DMA chapter. It should be noted that, after initializing the DMA counter and pointer registers and enabling DMA, data transmission is triggered by a character written into the Transmit Holding register.

When DMA is active the Receive Data Pending bit (RXDP, ISR.2), and the Transmit status bit interrupt sources are replaced by the DMA End Of Block Interrupt sources for transmit and receive, respectively.

The last DMA data word of a block of data will cause a DMA cycle followed by a transmit interrupt. This sequence will signal to the ST9 core to reinitialize the transmit DMA block counter. The Transmit End of Block status bit (TXEOB) should be reset by software in order to avoid undesired interrupt routines, especially in the initialisation routine (after reset) and after entering the End Of Block interrupt routine.

Similarly the last DMA data word of a block of data will cause a DMA cycle followed by a receiver data ready interrupt. This sequence will signal to the ST9 core to reinitialize the receiver DMA block counter. The Received End of Block status bit (RXEOB) should be reset by software in order to avoid undesired interrupt routines, especially in the initialisation routine (after reset) and after entering the End Of Block interrupt routine.

Remark: If properly initialized, the DMA controller starts a data transfer after and only if the running program has loaded the Transmitter Buffer Register with a value. In order to execute properly a DMA transmission, the End Of Block interrupt routine must include the following actions:

- Load the Transmitter Buffer Register (TXBR) with the first byte to transmit.
- Restore the DMA counter (TDCPR)
- Restore the DMA pointer (TDAPR)
- Reset the transmitter end of block bit TXEOB (IMR.5)
- Reset the transmitter holding empty bit TXHEM (ISR.1)
- Enable DMA

14.4 CONTROL REGISTERS

The relative pages of the SCI in the ST9 are:

- SCI number 1: page 24 (18h)
- SCI number 2: page 25 (19h) (when available)

The SCI is controlled by the following registers:

Address	Register
R240 (F0h)	Receiver DMA Transaction Counter Pointer Register
R241 (F1h)	Receiver DMA Source Address Pointer Register
R242 (F2h)	Transmitter DMA Transaction Counter Pointer Register
R243 (F3h)	Transmitter DMA Destination Address Pointer Register
R244 (F4h)	Interrupt Vector Register
R245 (F5h)	Address Compare Register
R246 (F6h)	Interrupt Mask Register
R247 (F7h)	Interrupt Status Register
R248 (F8h)	Receive Buffer Register same Address as Transmitter Buffer Register (Read Only)
R248 (F8h)	Transmitter Buffer Register same Address as Receive Buffer Register (Write only)
R249 (F9h)	Interrupt/DMA Priority Register
R250 (FAh)	Character Configuration Register
R251 (FBh)	Clock Configuration Register
R252 (FCh)	Baud Rate Generator Register
R253 (FDh)	Baud Rate Generator Register
R254 (FEh)	Reserved
R255 (FFh)	Reserved

ST9 - Serial Communication Interface (ST902x)

CONTROL REGISTERS (Continued)

RDCPR R240 (F0h) Read/Write
Receiver DMA Transaction Counter Pointer
Reset value: undefined

7							0
RC7	RC6	RC5	RC4	RC3	RC2	RC1	RR/M

b7-b1 = **RC7-RC1**: *Receive DMA Counter Pointer*. RDCPR contains the address of the pointer (in the Register File) of the DMA receiver transaction counter.

b0 = **RR/M**: *Receiver Register File/Memory Selector*. If this bit = "1" the Register File will be selected as Destination, if this bit = "0" the Memory space will be selected.

RDAPR R241 (F1h) Read/Write
Receiver DMA Source Address Pointer
Reset value: undefined

7							0
RA7	RA6	RA5	RA4	RA3	RA2	RA1	RD/P

b7-b1 = **RA7-RA1**: *Receive DMA Address Pointer*. RDAPR contains the address of the pointer (in the Register File) of the receiver DMA data source.

b0 = **RD/P**: *Receive DMA Data/Program Memory Selector*. If memory (RR/M = "0") has been selected for DMA transfers, when this bit = "1" receiver DMA transfers will go to Data Memory. If this bit = "0" receiver DMA transfers will go to Program Memory.

TDCPR R242 (F2h) Read/Write
Transmitter DMA Transaction Counter Pointer
Reset value: undefined

7							0
TC7	TC6	TC5	TC4	TC3	TC2	TC1	TR/M

b7-b1 = **TC7-TC1**: *Transmitter DMA Counter Pointer*. TDCPR contains the address of the pointer (in the Register File) of the DMA transmitter transaction counter.

b0 = **TR/M**: *Transmitter Register File/Memory Selector*. If this bit = "1" the Register File will be selected as Source, if this bit = "0" the Memory space will be selected.

TDAPR R243 (F3h) Read/Write
Transmitter DMA Destination Address Pointer
Reset value: undefined

7							0
TA7	TA6	TA5	TA4	TA3	TA2	TA1	TD/P

b7-b1 = **TA7-TA1**: *Transmitter DMA Address Pointer*. TDAPR contains the address of the pointer (in the Register File) of the transmitter DMA data source.

b0 = **TD/P**: *Transmitter DMA Data/Program Memory Selector*. If memory (TR/M = "0") has been selected for DMA transfers, when this bit = "1" transmitter DMA transfers come from Data Memory. If this bit = "0" transmitter DMA transfers come from Program Memory

IVR R244 (F4h) Read/Write
Interrupt Vector Register
Reset value: undefined

7						0	
V7	V6	V5	V4	V3	EV2	EV1	0

b7-b3 = **V7-V3**: *SCI Interrupt Vector Base Address*. User programmable interrupt vector bits for transmitter and receiver

b2-b1 = **EV2-EV1**: *Encoded Interrupt Source (Read only)*. EV2 and EV1 are set by hardware according to the interrupt source.

EV2	EV1	Interrupt source
0	0	Receiver Error (Overrun, Framing, Parity)
0	1	Break detect or address match
1	0	Receiver data ready/receiver DMA End of Block
1	1	Transmitter buffer or shift register empty transmitter DMA End of Block

b0 = **D0**: This bit is fixed by hardware. It always returns the value "0" when read.

CONTROL REGISTERS (Continued)

ACR R245 (F5h) Read/Write
Address/Data Compare Register

Reset value: undefined

7							0
AC7	AC6	AC5	AC4	AC3	AC2	AC1	AC0

b7-b0 = **AC7-AC0**: *Address/Compare Character*. With either 9th bit address mode, address after break mode, or character search, the received address will be compared to the value stored in this register. When a valid address matches this register content, the Receive Address Pending bit is set. After the RXAP bit is set in an addressed mode all received data words will be transferred to the Receiver Buffer Register.

IMR R246 (F6h) Read/Write
Interrupt Mask Register

Reset value: 0xx0 0000b

7							0
HSN	RXEOB	TXEOB	RXE	RXA	RXB	RXDI	TXDI

b7 = **HSN**: *Holding or shift register empty interrupt*. This bit selects the source of interrupt/DMA as the transmitter register empty event. If this bit is set to "1", a holding register empty will generate a transmitter register empty interrupt.

If this bit has a "0" value, a shift register empty will generate a transmitter register empty interrupt.

b6 = **RXEOB**: *Received End of Block*. This bit is set after a receiver DMA cycle to mark the end of a block of data. The last DMA data word will cause a DMA cycle followed by a receiver data ready interrupt. This sequence will signal to the ST9 core to reinitialize the receiver DMA block counter. RXEOB should be reset by software in order to avoid undesired interrupt routines, especially in the initialisation routine (after reset) and after entering the End Of Block interrupt routine.

Writing "0" in this bit will cancel the interrupt request.

Note. RXEOB can only be written with a "0" (RXEOB = set only by the ST9 core).

b5 = **TXEOB**: *Transmitter End of Block*. This bit is set in a transmitter DMA cycle to mark the end of a block of data. The last DMA data word will cause a DMA cycle followed by a transmitter interrupt. This sequence will signal to the ST9 core to reinitialize the transmitter DMA block counter. TXEOB should be reset by software in order to avoid undesired interrupt routines, especially in initialisation routine (after reset) and after entering the End Of Block interrupt routine.

Writing "0" in this bit will cancel the interrupt request.

Note. TXEOB can only be written with a 0 (TXEOB is set only by the ST9 core)

b4 = **RXE**: *Receiver Error Mask*. When this bit is set to "0", the receiver error bits: Overrun Error (OE), Parity Error (PE), and Framing Error (FE), cannot generate an interrupt.

b3 = **RXA**: *Receiver Address Mask*. When this bit is set to "0", the Receiver Address Pending (RXAP) bit cannot generate an interrupt.

b2 = **RXB**: *Receiver Break Mask*. When this bit is set to "0", the Receiver Break Pending (RBP) bit cannot generate an interrupt.

b1 = **RXDI**: *Receiver Data Interrupt Mask*. When this bit is set to "0", the Receiver Data Pending (RDP) bit and the Receiver End of Block (RXEOB) bit cannot generate an interrupt. RXDI has no effect on DMA transfers.

b0 = **TXDI**: *Transmitter Data Interrupt Mask*. When this bit is set to "0", neither the Transmitter Holding or Shift Register Empty (TXHEM) bit or the Transmitter End of Block (TXEOB) bit can generate an interrupt. TXDI has no effect on DMA transfers.

ST9 - Serial Communication Interface (ST902x)

CONTROL REGISTERS (Continued)

ISR R247 (F7h) Read/Write
Interrupt Status Register

Reset value: undefined

7							0
OE	FE	PE	RXAP	RXBP	RXDP	TXHEM	TXSEM

b7 = **OE**: *Overrun Error Pending*. This bit is set to a logic "1" if the data in the Receiver Buffer Register was not read by the CPU before the next character was transferred into the Receiver Buffer Register (the previous data is lost). It is cleared by writing a zero into OE.

b6 = **FE**: *Framing Error Pending bit*. This bit is set to a logic "1" if the received data word did not have a valid stop bit. It is cleared by writing a zero to the bit. In the case where a framing error occurs when the SCI is programmed in an address mode, and is monitoring for an address, this interrupt is asserted and the corrupted data element is transferred to the Receiver Buffer Register.

b5 = **PE**: *Parity Error Pending*. This bit is set to a logic "1" if the received word did not have the correct even or odd parity bit. It is cleared by writing a zero into PE.

b4 = **RXAP**: *Receiver Address Pending*. RXAP is set to "1" after an interrupt acknowledged in the address mode. The source of this interrupt is given by the couple of bits (AMEN, AM) as detailed in the "Interrupt/DMA Priority Register" description. RXAP is cleared by software.

b3 = **RXBP**: *Receiver Break Pending bit*. This bit is set to a logic "1" if the received data input is held low for the full word transmission time (start bit, data bits, parity bit, stop bit). It is cleared by writing a zero into RXBP.

b2 = **RXDP**: *Receiver Data Pending bit*. This bit is set to a logic "1" when data is loaded into the Receiver Holding Register. It is cleared by writing a zero into RXDP.

b1 = **TXHEM**: *Transmitter buffer register Empty*. This bit is set to a logic "1" if the Holding Register is empty. It is cleared by writing a zero into TXHEM.

b0 = **TXSEM**: *Transmitter Shift Register Empty*. This bit is set to a logic "1" if the Shift Register has completed the transmission of the available data. It is cleared by writing a "0" into TXSEM.

Note.

The Interrupt Status Register bits can be reset by writing a "0" but it is not possible to write a "1" into any bit in this register. It is mandatory to clear the interrupt source by writing a "0" in the pending bit when executing the interrupt service routine.

When servicing an interrupt routine, the User should reset **ONLY** the pending bit relative to the serviced interrupt routine (and not reset the other pending bits).

RXBR R248 (F8h) Read only
Receive Buffer Register

Reset value: undefined

7							0
RD7	RD6	RD5	RD4	RD3	RD2	RD1	RD0

b7-b0 = **RD7-RD0**: *Received Data*. This register stores the data portion of the received word. The data will be transferred from the Receiver Shift Register into the Receiver Buffer Register at the end of the word. All receiver interrupt conditions will be updated at the time of transfer. If the selected character format is less than 8 bits, unused most significant bits will forced to "1".

TXBR R248 (F8h) Write only
Transmitter Buffer Register

Reset value: undefined

7							0
TD7	TD6	TD5	TD4	TD3	TD2	TD1	TD0

b7-b0 = **TD7-TD0**: *Transmit Data*. The ST9 core will load the data for transmission into this register. The SCI will transfer the data from the buffer into the Shift Register when available. At the transfer, the Transmitter Buffer Register interrupt is updated. If the selected word format is less than 8 bits, the unused most significant bits are not significant.

CONTROL REGISTERS (Continued)

IDPR R249 (F9h) Read/Write
Interrupt/DMA Priority Register

Reset value: undefined

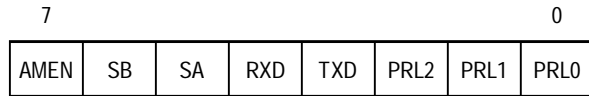

b7 = **AMEN**: *Address Mode Enable*. This bit, with AM (R250), decodes the desired addressing/9th data bit/character match operation.

AMEN	AM	
0	0	Address interrupt if 9th data bit =1
0	1	Address interrupt if character match
1	0	Address interrupt if character match and 9th data bit =1
1	1	Address interrupt if character match with word immediately following Break

In an addressed mode the SCI will monitor the input serial data until its address is detected.

Upon reception of address, the RXAP bit (in the Interrupt Status Register) is set and an interrupt cycle can begin. The address character will not be transferred into the Receiver Buffer Register but, all data following the matched SCI address and preceding the next address word will be transferred to the Receiver Buffer Register and the proper interrupts updated. If the address does not match, all data following this unmatched address will not be transferred to the Receiver Buffer Register.

In any of the cases the RXAP bit must be reset by software before the next word is transferred into the Buffer Register.

When AMEN = "0" and AM = "1", a useful character search function is performed. This allows the SCI to generate an interrupt whenever a specific character is encountered (e.g. Carriage Return).

b6 = **SB**: *Set Break*. If this bit is set, a break will be transmitted following the transmission of all data in the Transmitter Shift Register and the Buffer Register.

The break will be a "0" value on the transmitter data output for at least one complete word format. If software does not reset SB before the minimum break length has finished, the break condition will continue until software resets SB. The SCI terminates the break condition with a "1" on the transmitter data output for one transmission clock period.

b5 = **SA**: *Set Address*. If an address/9th data bit mode is selected, SA value will be loaded for transmission. Setting this bit indicates an address word. SA will be cleared by hardware after it is loaded into the Shift Register. Proper procedure would be, when the Transmitter Buffer Register is empty, to load the value of SA and then load the data into the Transmitter Buffer Register.

b4 = **RXD**: *Receiver DMA Mask*. If this bit is "0", no receiver DMA request will be generated, and the RXDP bit in the Interrupt Status Register can request an interrupt. If RXD is set to "1", the RXDP bit can request a DMA transfer. This bit is reset by hardware when the transaction counter value decrements to zero. At that time a receiver "end of block" interrupt can occur.

b3 = **TXD**: *Transmitter DMA Mask*. If this bit is "0" no transmitter DMA request will be generated and the TXHEM (or TXSEM) bit in the Interrupt Status Register can request an interrupt. If TXD is set, the TXHEM (or TXSEM) bit can request a DMA transfer. This bit is reset by hardware when the transaction counter value decrements to zero. At that time a transmitter End Of Block interrupt can occur.

b2-b0 = **PRL2, PRL1, PRL0**: *SCI Interrupt/DMA Priority bits*. The priority for the SCI is encoded with (PRL2,PRL1,PRL0). A priority value of 0 has the highest priority, a value of 7 has no priority.

When user has defined a priority level for the SCI, priorities inside the SCI are hardware defined. These SCI internal priorities are:

receiver DMA request	higher priority
transmitter DMA request	
receiver interrupt	lower priority
transmitter interrupt	

ST9 - Serial Communication Interface (ST902x)

CONTROL REGISTERS (Continued)

CHCR R250 (FAh) Read/Write
Character Configuration Register

Reset value: undefined

7							0
AM	EP	PEN	AB	SB1	SB0	WL1	WL0

b7 = **AM**: *Address Mode*. decodes the desired addressing/9th data bit/character match operation in conjunction with AMEN (IDPR.7, R249).

b6 = **EP**: *Even Parity*. When parity is enabled, this bit selects between even or odd parity. If this bit is equal to "0", odd parity will be selected. If this bit is equal to "1", even parity will be selected.

b5 = **PEN**: *Parity Enable*. When this bit is equal to "1", a parity bit is generated (transmit data) or checked (received data) between the last word bit and the stop bits. If the address/9th bit is enabled, the parity bit will precede the address/9th bit

(The parity bit is used to produce an even or odd number of 1's when the parity bit and all data bits are summed. The 9th bit is never included in the parity calculation).

b4 = **AB**: *Address/9th Bit*. If this bit equals "1" the transmit and receive character format will include a bit between the parity bit and the first stop bit. This bit can be used to address the SCI or as a ninth data bit.

b3-b2 = **SB1-SB2**: *Stop Bits*. This bit field specifies the number of stop bits to be included in the data format

SB2	SB1	Number of stop bits	
		in 16X mode	in 1X mode
0	0	1	1
0	1	1.5	2
1	0	2	2
1	1	2.5	3

b1-b0 = **WL1, WL0**: These two bits specify the number of data bits in each transmitted or received character. The following table shows the coding of WL.

WL1	WL0	Data Length
0	0	5 bits
0	1	6 bits
1	0	7 bits
1	1	8 bits

CCR R251 (FBh) Read/Write
Clock Configuration Register

Reset value: 0000 0000 (00h)

7							0
XTCLK	OCLK	XRX	XBRG	CD	AEN	LBEN	STPEN

b7 = **XTCLK**:

b6 = **OCLK**: These two bits select the source for the transmitter clock. The following table shows the coding of XTCLK and OCLK.

XTCLK	OCLK	Pin Function
0	0	Pin is used as a general I/O
0	1	Pin = TXCLK (used as an input)
1	0	Pin = CLKOUT (outputs the Baud Rate Generator clock)
1	1	Pin = CLKOUT (outputs the Serial exp. mode clock)

b5 = **XRX**: *External Receiver Clock Source*. If this bit is "1", the receiver will use the external receiver clock pin for its clock source. The external clock must be equal to 16 times the data rate or equal to the data rate depending on the bit CD.

b4 = **XBRG**: *Baud Rate Generator Clock Source*. If this bit is "1", the baud rate generator will use the external receiver clock pin for its clock source. If this bit is "0", the baud rate generator will use the ST9 system clock (INTCLK).

b3 = **CD**: *Clock Divisor*. If CD = "1", both the receiver and the transmitter will be in 1X clock mode. In 1X clock mode, the transmitter will transmit data at one data bit per clock period. If this bit is "0", both the receiver and the transmitter will be in 16X mode. In 16X mode each data bit period will be 16 clock periods long.

The CD value will determine the synchronous/asynchronous SCI configuration mode.

b2 = **AEN**: *Auto Echo Enable*. If AEN = "1", the SCI is in auto echo mode. In this mode the SCI transmitter is disconnected from the transmitter data-out pin (SOUT). The transmitter data-out pin (SOUT) is driven directly by the receiver data-in pin (SIN). The receiver remains connected to the receiver data-in pin (SIN) and is operational, unless loopback mode is also selected.

ST9 - Serial Communication Interface (ST902x)

CONTROL REGISTERS (Continued)

b1 = **LBEN**: *Loopback Enable*. If this bit is set to "1", the loopback mode is enabled. In this mode the transmitter output is set to "1", the receiver input is disconnected, and the output of the Transmitter Shift Register is looped back into the Receiver Shift Register input. All interrupt sources for both the transmitter and the receiver are operational.

b0 = **STPEN**: *Stick Parity Enable*. If this bit is set to "1", the transmitter and the receiver will use the opposite parity type selected by the even parity bit (EP).

EP	SPEN	Parity (Transmitter & Receiver)
0 (odd)	0	Odd
1 (even)	0	Even
0 (odd)	1	Even
1 (even)	1	Odd

BRGHR R252 (FCh) Read/Write
Baud Rate Generator Register, High byte.

Reset value: undefined

15							8
BG15	BG14	BG13	BG12	BG11	BG10	BG9	BG8

BRGLR R253 (FDh) Read/Write
Baud Rate Generator Register, Low byte.

Reset value: undefined

7							0
BG7	BG6	BG5	BG4	BG3	BG2	BG1	BG0

b15-b0: *The Baud Rate generator* is a programmable divide by "N" counter which can be used to generate the clocks for the transmitter and/or receiver. This counter divides the clock input by the value in the Baud Rate Generator Register. The minimum baud rate divisor is 2 and the maximum divisor is $2^{16}-1$. After initialization of the baud rate generator, the divisor value is immediately loaded into the counter. This prevents potentially long random counts on the initial load.

If set to 0 or 1, the Baud Rate Generator is stopped.

Figure 14-11. SCI Functional Scheme

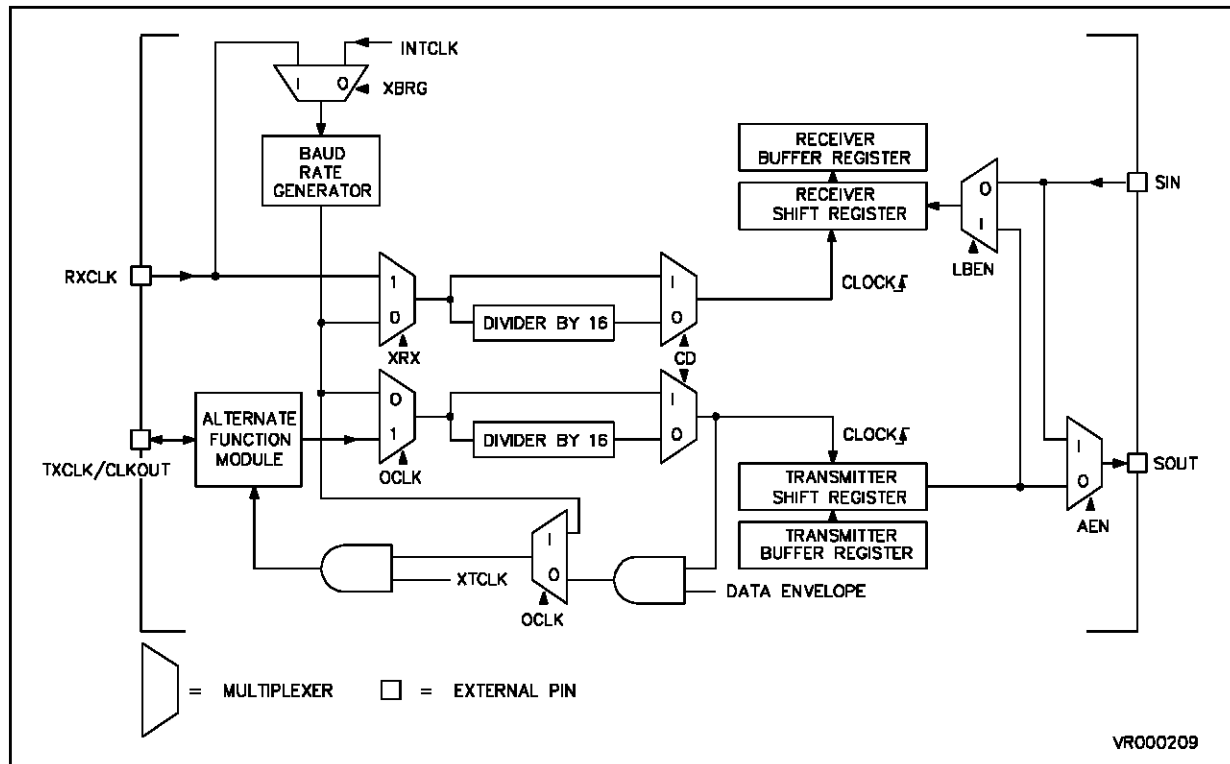

ST9 - Serial Communication Interface (ST902x)

Notes :

REGISTER MAP

1	INTRODUCTION				
2	CORE ARCHITECTURE				15
CICR	R230 (E6h) System	Read/Write	Central Interrupt Control Register		19
FLAGR	R231 (E7h) System	Read/Write	Flag Register		20
RP0	R232 (E8h) System	Read/Write	Register Pointer 0		21
RP1	R233 (E9h) System	Read/Write	Register Pointer 1		21
PPR	R234 (EAh) System	Read/Write	Page Pointer Register		23
MODER	R235 (EBh) System	Read/Write	Mode Register		23
USP	R236 (ECh) System	Read/Write	User Stack Pointer High Byte		25
USP	R237 (EDh) System	Read/Write	User Stack Pointer Low Byte		25
SSP	R238 (EEh) System	Read/Write	System Stack Pointer High Byte		25
SSP	R239 (EFh) System	Read/Write	System Stack Pointer Low Byte		25
4	INTERRUPTS				29
CICR	R230 (E6h) System	Read/Write	Central Interrupt Control Register		44
EITR	R242 (F2h) Page 0	Read/Write	External Interrupt Trigger Event Register		44
EIPR	R243 (F3h) Page 0	Read/Write	External Interrupt Pending Register		44
EIMR	R244 (F4h) Page 0	Read/Write	External Interrupt Mask-bit Register		45
EIPLR	R245 (F5h) Page 0	Read/Write	External Interrupt Priority Level Register		45
EIVR	R246 (F6h) Page 0	Read/Write	External Interrupt Vector Register		45
NICR	R247 (F7h) Page 0	Read/Write	Nested Interrupt Control Register		45
5	ON-CHIP DMA				47
DCPR	Address set by Peripheral	Read/Write	DMA Counter Pointer Register		52
IDCR	Address set by Peripheral	Read/Write	Generic Peripheral Interrupt and DMA Control		52
DAPR	Address set by Peripheral	Read/Write	DMA Address Pointer Register		52
6	CLOCK				53
MODER	R235 (EBh) System	Read/Write	Mode Register		54
7	RESET				57
8	EXTERNAL MEMORY INTERFACE				61
WCR	R252 (FCh) Page 0	Read/Write	Wait Control Register		70
9	I/O PORTS				71

10 HANDSHAKE/DMA CONTROLLER			77
HDCTL5		Read/Write Handshake/DMA Control Register	88
11 SERIAL PERIPHERAL INTERFACE			91
SPIDR	R253 (FDh) Page 0	Read/Write SPI Data Register	94
SPICR	R254 (FEh) Page 0	Read/Write SPI Control Register	94
12 TIMER/WATCHDOG			101
WDTHR	R248 (F8h) Page 0	Read/Write Timer/Watchdog Counter Register, High byte	105
WDTLR	R249 (F9h) Page 0	Read/Write Timer/Watchdog Counter Register, Low byte.	105
WDTPR	R250 (FAh) Page 0	Read/Write Timer/Watchdog Prescaler Register	105
WDTCR	R251 (FBh) Page 0	Read/Write Timer/Watchdog Control Register	105
13 MULTIFUNCTION TIMER			107
REG0HR	R240 (F0h)	Read/Write Capture Load Register 0 (High)	121
REG0LR	R241 (F1h)	Read/Write Capture Load Register 0 (Low)	121
REG1HR	R242 (F2h)	Read/Write Capture Load Register 1 (High)	121
REG1LR	R243 (F3h)	Read/Write Capture Load Register 1 (Low)	121
CMP0HR	R244 (F4h)	Read/Write Compare 0 Register (High)	121
CMP0LR	R245 (F5h)	Read/Write Compare 0 Register (Low)	121
CMP1HR	R246 (F6h)	Read/Write Compare 1 Register (High)	121
CMP1LR	R247 (F7h)	Read/Write Compare 1 Register (Low)	121
TCR	R248 (F8h)	Read/Write Timer Control Register	122
TMR	R249 (F9h)	Read/Write Timer Mode Register	122
ICR	R250 (FAh)	Read/Write External Input Control Register	123
PRSR	R251 (FBh)	Read/Write Prescaler Register	124
OACR	R252 (FCh)	Read/Write Output A Control Register	124
OBCR	R253 (FDh)	Read/Write Output B Control Register	125
FLAGR	R254 (FEh)	Read/Write Flags Register	125
IDMR	R255 (FFh)	Read/Write Interrupt/DMA Mask Register	126
DCPR	R240 (F0h)[R244 (F4h)]	Read/Write DMA Counter Pointer Register	126
DAPR	R241 (F1h) [R245 (F5h)]	Read/Write DMA Address Pointer Register	127
IVR	R242 (F2h) [R246 (F6h)]	Read/Write Interrupt Vector Register	127
IDCR	R243 (F3h) [R247 (F7h)]	Read/Write Interrupt/DMA Control Register	128
IOCR	R248 (F8h)	Read/Write I/O Connection Register	128

14 SERIAL COMMUNICATIONS INTERFACE				129
RDCPR	R240	(F0h)	Read/Write Receiver DMA Transaction Counter Pointer	138
RDAPR	R241	(F1h)	Read/Write Receiver DMA Source Address Pointer	138
TDCPR	R242	(F2h)	Read/Write Transmitter DMA Transaction Counter Pointer	138
TDAPR	R243	(F3h)	Read/Write Transmitter DMA Destination Address Pointer	138
IVR	R244	(F4h)	Read/Write Interrupt Vector Register	138
ACR	R245	(F5h)	Read/Write Address/Data Compare Register	139
IMR	R246	(F6h)	Read/Write Interrupt Mask Register	139
ISR	R247	(F7h)	Read/Write Interrupt Status Register	140
RXBR	R248	(F8h)	Read only Receive Buffer Register	140
TXBR	R248	(F8h)	Write only Transmitter Buffer Register	140
IDPR	R249	(F9h)	Read/Write Interrupt/DMA Priority Register	141
CHCR	R250	(FAh)	Read/Write Character Configuration Register	142
CCR	R251	(FBh)	Read/Write Clock Configuration Register	142
BRGHR	R252	(FCh)	Read/Write Baud Rate Generator Register, High byte.	143
BRGLR	R253	(FDh)	Read/Write Baud Rate Generator Register, Low byte.	143

15 ELECTRICAL CHARACTERISTICS

ABSOLUTE MAXIMUM RATINGS

Symbol	Parameter	Value	Unit
V_{DD}	Supply Voltage	-0.3 to 7.0	V
AV_{DD} , AV_{SS}	Analog Supply Voltage	$V_{SS} = AV_{SS} < AV_{DD} \leq V_{DD}$	V
V_I	Input Voltage	-0.3 to $V_{DD} + 0.3$	V
V_O	Output Voltage	-0.3 to $V_{DD} + 0.3$	V
T_{STG}	Storage Temperature	-55 to +150	°C
I_{INJ}	Pin Injection Current Digital Input	-5 to +5	mA
	Maximum Accumulated Pin injection Current in the device	-50 to +50	mA

Note: Stresses above those listed as "absolute maximum ratings" may cause permanent damage to the device. This is a stress rating only and functional operation of the device at these conditions is not implied. Exposure to maximum rating conditions for extended periods may affect device reliability. All voltages are referenced to V_{SS}

RECOMMENDED OPERATING CONDITIONS

Symbol	Parameter	Value		Unit
		Min.	Max.	
T_A	Operating Temperature	-40	85	°C
V_{DD}	Operating Supply Voltage	4.5	5.5	V
f_{osCE}	External Oscillator Frequency		24	MHz
f_{osCI}	Internal Clock Frequency (INTCLK)		12	MHz

ST9020, 27, 28

DC ELECTRICAL CHARACTERISTICS

$V_{DD} = 5V \pm 10\%$ $T_A = -40^\circ C$ to $+85^\circ C$, unless otherwise specified)

Symbol	Parameter	Test Conditions	Value			Unit
			Min.	Typ.	Max.	
V_{IHCK}	Clock Input High Level	External Clock	$0.7 V_{DD}$		$V_{DD} + 0.3$	V
V_{ILCK}	Clock Input Low Level	External Clock	- 0.3		$0.3 V_{DD}$	V
V_{IH}	Input High Level	TTL	2.0		$V_{DD} + 0.3$	V
		CMOS	$0.7 V_{DD}$		$V_{DD} + 0.3$	V
V_{IL}	Input Low Level	TTL	- 0.3		0.8	V
		CMOS	- 0.3		$0.3 V_{DD}$	V
V_{IHRS}	\overline{RESET} Input High Level		$0.7 V_{DD}$		$V_{DD} + 0.3$	V
V_{ILRS}	\overline{RESET} Input Low Level		-0.3		$0.3 V_{DD}$	V
V_{HYRS}	\overline{RESET} Input Hysteresis		0.3		1.5	V
V_{OH}	Output High Level	Push Pull, $I_{load} = -0.8mA$	$V_{DD} - 0.8$			V
V_{OL}	Output Low Level	Push Pull or Open Drain, $I_{load} = 1.6mA$			0.4	V
I_{WPU}	Weak Pull-up Current	Bidirectional Weak Pull-up, $V_{OL} = 0V$	- 50	- 200	- 420	μA
I_{LKIO}	I/O Pin Input Leakage	Input/Tri-State, $0V < V_{IN} < V_{DD}$	- 10		+ 10	μA
I_{LKRS}	\overline{Reset} Pin Input Leakage	$0V < V_{IN} < V_{DD}$	- 30		+ 30	μA
I_{LKAP}	Active Pull-up Input Leakage	$0V < V_{IN} < 0.8V$	- 10		+ 10	μA
I_{LKOS}	OSCIN Pin Input Leakage	$0V < V_{IN} < V_{DD}$	- 10		+ 10	μA

Note: All I/O Ports are configured in Bidirectional Weak Pull-up Mode with no DC load, External Clock pin (OSCIN) is driven by square wave external clock. No peripheral working.

AC TEST CONDITIONS

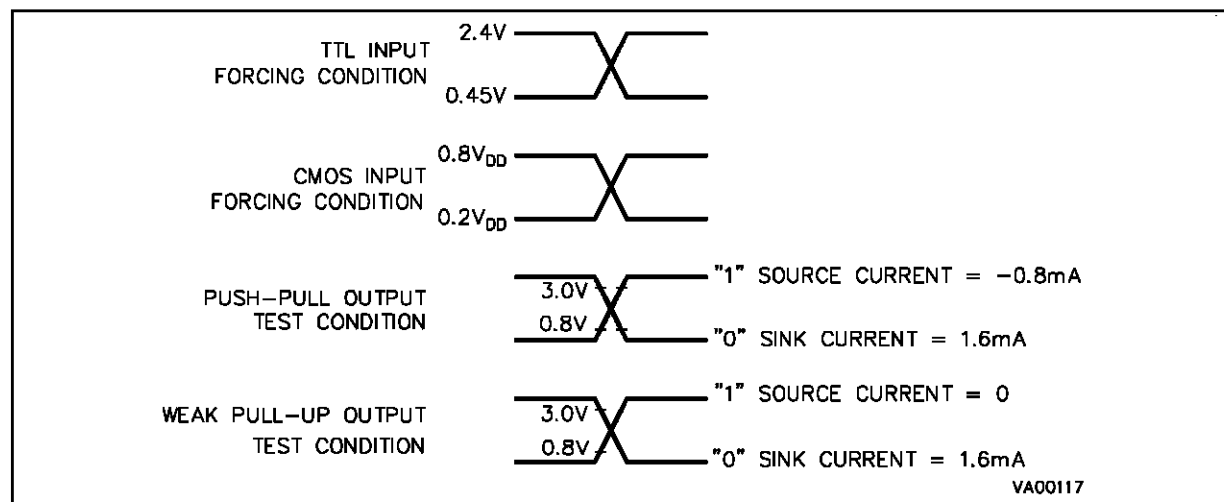

AC ELECTRICAL CHARACTERISTICS

$V_{DD} = 5V \pm 10\%$ $T_A = -40^\circ C$ to $+85^\circ C$, unless otherwise specified

Symbol	Parameter	Test Conditions (f_{osc})	Max. Value	Unit
I _{DD}	Run Mode Current no CPUCLK prescale Clock divide by 2	24 MHz	40	mA
		4 MHz	12	mA
I _{DP2}	Run Mode Current Prescale divide by 2 Clock divide by 2	24 MHz	25	mA
		4 MHz	8	mA
I _{WFI}	WFI Mode Current no CPUCLK prescale Clock divide by 2	24 MHz	15	mA
		4 MHz	5	mA
I _{HALT}	HALT Mode Current		10	μA

CLOCK TIMING TABLE

($V_{DD} = 5V \pm 10\%$, $T_A = -40^{\circ}C$ to $+85^{\circ}C$)

N°	Symbol	Parameter	Value		Unit	Note
			Min.	Max.		
1	TpC	OSCIN Clock Period	41.5		ns	1
			83		ns	2
2	TrC, TfC	OSCIN Rise and Fall Time		12	ns	
3	TwCL, TwCH	OSCIN Low and High Width	17	25	ns	1
			38		ns	2

Notes:

1. Clock divided by 2 internally (MODER.DIV2=1)
2. Clock not divided by 2 internally (MODER.DIV2=0)

CLOCK TIMING

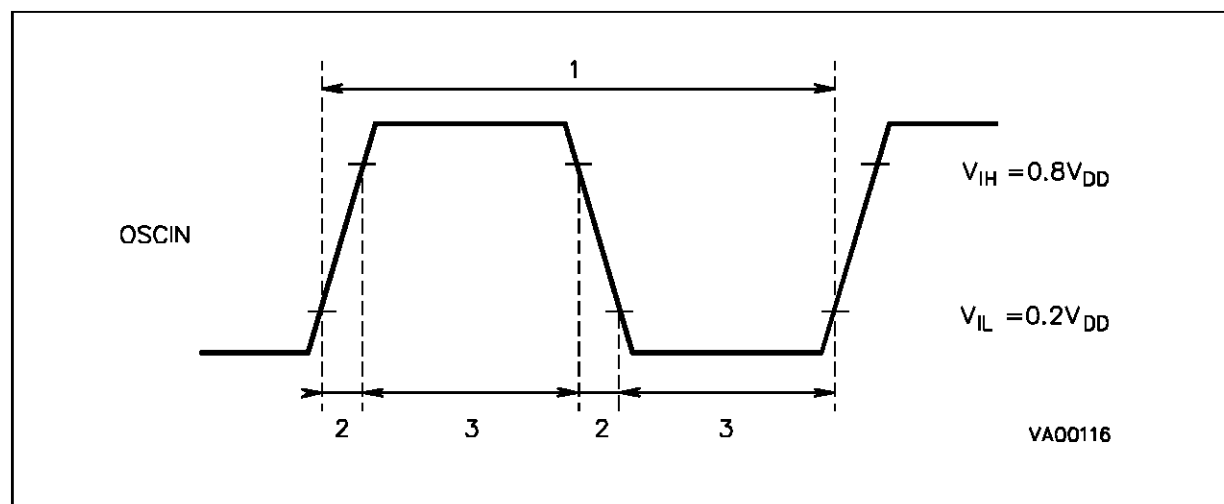

EXTERNAL BUS TIMING TABLE ($V_{DD} = 5V \pm 10\%$, $T_A = -40^\circ\text{C}$ to $+85^\circ\text{C}$, $C_{load} = 50\text{pF}$, $CPUC_{LK} = 12\text{MHz}$, unless otherwise specified)

N°	Symbol	Parameter	Value (Note)				Unit
			OSCIN Divided By 2	OSCIN Not Divided By 2	Min.	Max.	
1	T _{sA} (AS)	Address Set-up Time before $\overline{AS} \uparrow$	T _{pC} (2P+1) -22	T _{wCH} +T _{pC} -18	20		ns
2	T _{hAS} (A)	Address Hold Time after $\overline{AS} \uparrow$	T _{pC} -17	T _{wCL} -13	25		ns
3	T _{dAS} (DR)	$\overline{AS} \uparrow$ to Data Available (read)	T _{pC} (4P+2W+4) -52	T _{pC} (2P+W+2) -51		115	ns
4	T _{wAS}	\overline{AS} Low Pulse Width	T _{pC} (2P+1) -7	T _{wCH} +T _{pC} -3	35		ns
5	T _{dAz} (DS)	$\overline{DS} \downarrow$ to Address Float			12		ns
6	T _{wDSR}	\overline{DS} Low Pulse Width (read)	T _{pC} (4P+2W+3) -20	T _{wCH} +T _{pC} (2P+W+1) -16	105		ns
7	T _{wDSW}	\overline{DS} Low Pulse Width (write)	T _{pC} (2P+2W+2) -13	T _{pC} (P+W+1) -13	70		ns
8	T _{dDSR} (DR)	$\overline{DS} \downarrow$ to Data Valid Delay (read)	T _{pC} (4P+2W-3) -50	T _{wCH} +T _{pC} (2P+W+1) -46		75	ns
9	T _{hDR} (DS)	Data to $\overline{DS} \uparrow$ Hold Time (read)	0	0	0		ns
10	T _{dDS} (A)	$\overline{DS} \uparrow$ to Address Active Delay	T _{pC} -7	T _{wCL} -3	35		ns
11	T _{dDS} (AS)	$\overline{DS} \uparrow$ to $\overline{AS} \downarrow$ Delay	T _{pC} -18	T _{wCL} -14	24		ns
12	T _{sR/W} (AS)	R/W Set-up Time before $\overline{AS} \uparrow$	T _{pC} (2P+1) -22	T _{wCH} +T _{pC} -18	20		ns
13	T _{dDSR} (R/W)	$\overline{DS} \uparrow$ to R/W and Address Not Valid Delay	T _{pC} -9	T _{wCL} -5	33		ns
14	T _{dDW} (DSW)	Write Data Valid to $\overline{DS} \downarrow$ Delay (write)	T _{pC} (2P+1) -32	T _{wCH} +T _{pC} -28	10		ns
15	T _{hDS} (DW)	Data Hold Time after $\overline{DS} \uparrow$ (write)	T _{pC} -9	T _{wCL} -5	33		ns
16	T _{dA} (DR)	Address Valid to Data Valid Delay (read)	T _{pC} (6P+2W+5) -68	T _{wCH} +T _{pC} (3P+W+2) -64		140	ns
17	T _{dAs} (DS)	$\overline{AS} \uparrow$ to $\overline{DS} \downarrow$ Delay	T _{pC} -18	T _{wCL} -14	24		ns

EXTERNAL WAIT TIMING TABLE ($V_{DD} = 5V \pm 10\%$, $T_A = -40^\circ\text{C}$ to $+85^\circ\text{C}$, $C_{load} = 50\text{pF}$, $INTCLK = 12\text{MHz}$, Push-pull output configuration, unless otherwise specified)

N°	Symbol	Parameter	Value (Note)				Unit
			OSCIN Divided By 2	OSCIN Not Divided By 2	Min.	Max.	
1	T _{dAs} (WAIT)	$\overline{AS} \uparrow$ to $\overline{WAIT} \downarrow$ Delay	2(P+1)T _{pC} -29	2(P+1)T _{pC} -29		40	ns
2	T _{dAs} (WAIT)	$\overline{AS} \uparrow$ to $\overline{WAIT} \downarrow$ Min. Delay	2(P+W+1)T _{pC} -4	2(P+W+1)T _{pC} -4	80		ns
3	T _{dAs} (WAIT)	$\overline{AS} \uparrow$ to $\overline{WAIT} \downarrow$ Max. Delay	2(P+W+1)T _{pC} -29	2(P+W+1)T _{pC} -29		83W+40	ns

Note: (for both table) The value in the left hand two columns show the formula used to calculate the timing minimum or maximum from the oscillator clock period, prescale value and number of wait cycles inserted. The value in the right hand two columns show the timing minimum and maximum for an external clock at 24 MHz divided by 2, prescaler value of zero and zero wait status.

Legend:
P = Clock Prescaling Value
W = Wait Cycles

T_{pC} = OSCIN Period
T_{wCH} = High Level OSCIN half period
T_{wCL} = Low Level OSCIN half period

EXTERNAL BUS TIMING

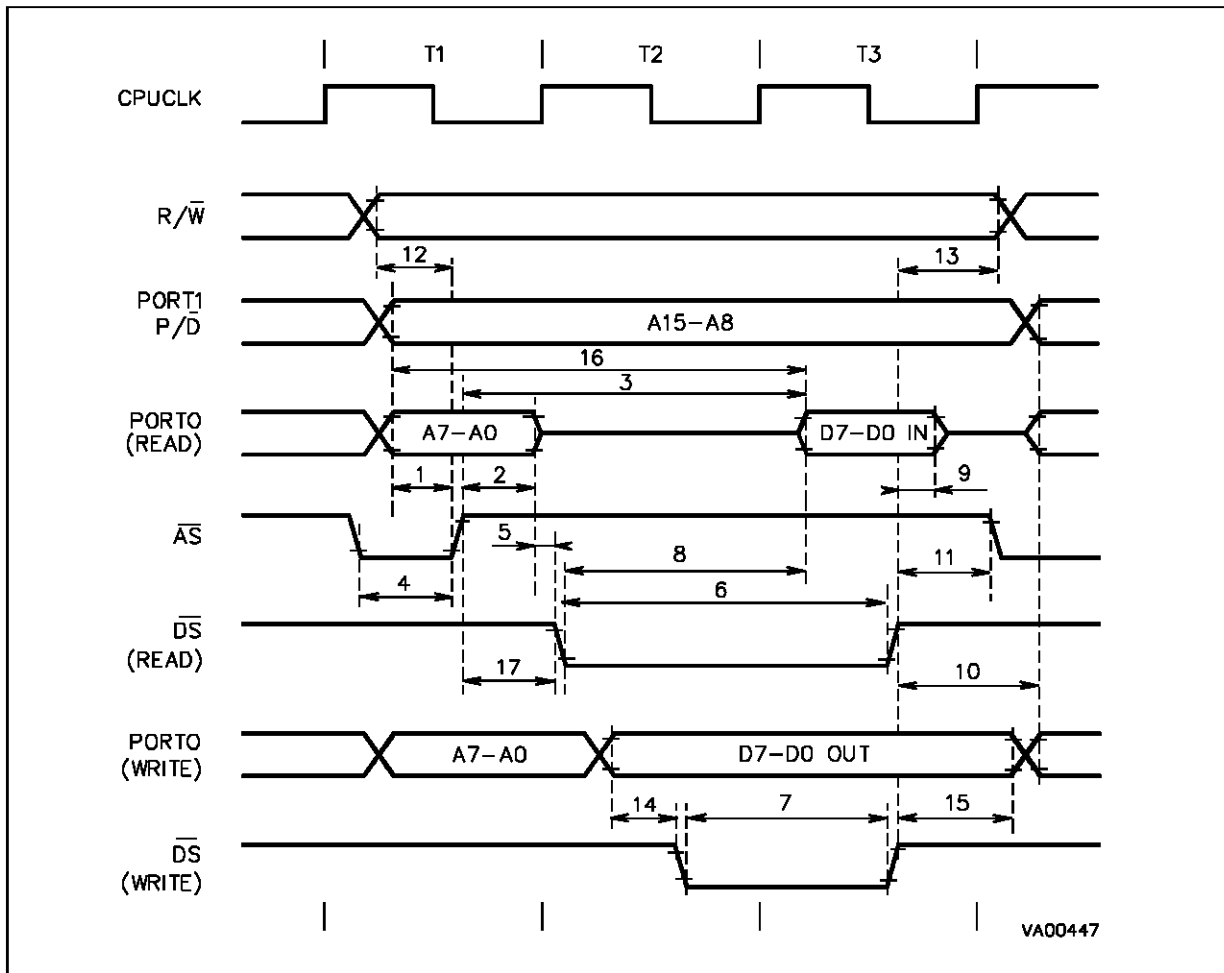

EXTERNAL WAIT TIMING

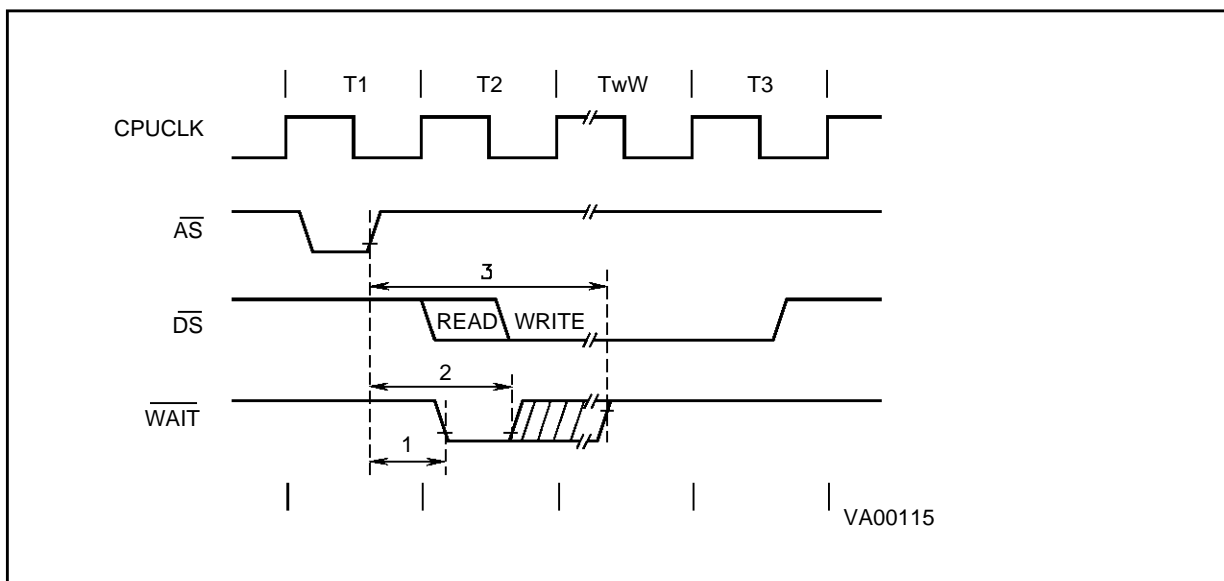

HANDSHAKE TIMING TABLE ($V_{DD} = 5V \pm 10\%$, $T_A = -40^\circ\text{C}$ to $+85^\circ\text{C}$, $C_{load} = 50\text{pF}$, $\text{INTCLK} = 12\text{MHz}$, Push-pull output configuration, unless otherwise specified)

N°	Symbol	Parameter	Value (Note)				Min.	Max.	Unit
			OSCIN Divided By 2		OSCIN Not Divided By 2				
			Min.	Max.	Min.	Max.			
1	TwRDY	RDRDY, WRRDY Pulse Width in One Line Handshake	$2T_{pC}$ $(P+W+1) - 18$		T_{pC} $(P+W+1) - 18$		65		ns
2	TwSTB	$\overline{\text{RDSTB}}$, $\overline{\text{WRSTB}}$ Pulse Width	$2T_{pC} + 12$		$T_{pC} + 12$		95		ns
3	TdST (RDY)	$\overline{\text{RDSTB}}$, or $\overline{\text{WRSTB}} \uparrow$ to RDRDY or WRRDY \downarrow		$T_{pC} + 45$		$(T_{pC} - T_{wCL}) + 45$		87	ns
4	TsPD (RDY)	Port Data to RDRDY \uparrow Set-up Time	$(2P+2W+1)$ $T_{pC} - 25$		$T_{wCH} + (W+P)$ $T_{pC} - 25$		16		ns
5	TsPD (RDY)	Port Data to WRRDY \downarrow Set-up Time in One Line Handshake	43		43		43		ns
6	ThPD (RDY)	Port Data to WRRDY \downarrow Hold Time in One Line Handshake	0		0		0		ns
7	TsPD (STB)	Port Data to $\overline{\text{WRSTB}} \uparrow$ Set-up Time	10		10		10		ns
8	ThPD (STB)	Port Data to $\overline{\text{WRSTB}} \uparrow$ Hold Time	25		25		25		ns
9	TdSTB (PD)	$\overline{\text{RDSTBD}} \uparrow$ to Port Data Delay Time in Bidirectional Handshake		35		35		35	ns
10	TdSTB (PHZ)	$\overline{\text{RDSTB}} \uparrow$ to Port High-Z Delay Time in Bidirectional Handshake		25		25		25	ns

Note: The value in the left hand two columns show the formula used to calculate the timing minimum or maximum from the oscillator clock period, prescale value and number of wait cycles inserted.

The value in the right hand two columns show the timing minimum and maximum for an external clock at 24 MHz divided by 2, prescaler value of zero and zero wait status.

Legend:

P = Clock Prescaling Value (R235.4.3.2)

W = Programmable Wait Cycles (R252.2.1.0/5,4,3) + External Wait Cycles

HANDSHAKE TIMING

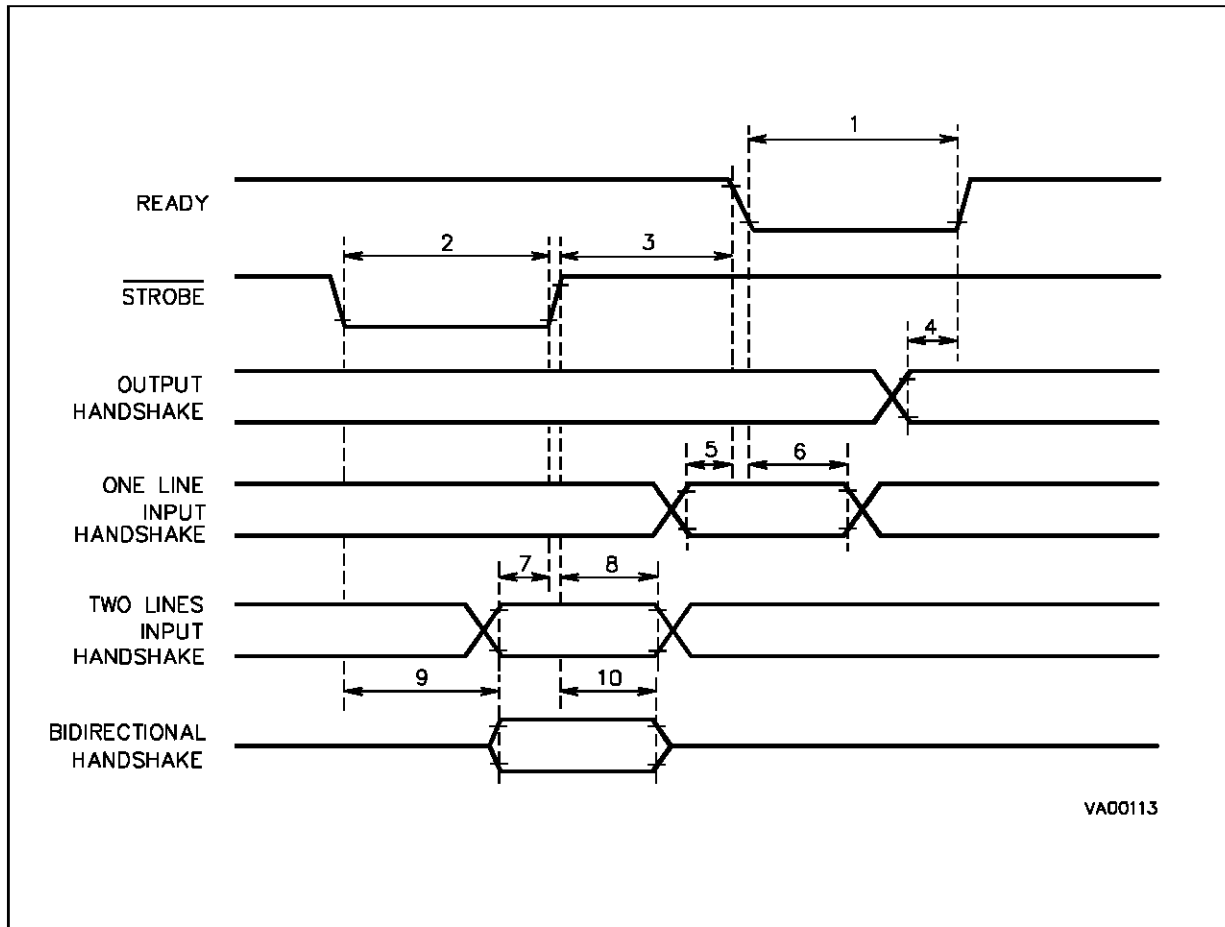

BUS REQUEST/ACKNOWLEDGE TIMING TABLE ($V_{DD} = 5V \pm 10\%$, $T_A = -40^\circ C$ to $+85^\circ C$, $C_{load} = 50pF$, $INTCLK = 12MHz$, Push-pull output configuration, unless otherwise specified)

N°	Symbol	Parameter	Value (Note)				Unit
			OSCIN Divided By 2	OSCIN Not Divided By 2	Min.	Max.	
1	TdBR (BACK)	$\overline{BREQ} \downarrow$ to $\overline{BUSACK} \downarrow$	$TpC+8$	$TwCL+12$	50		ns
			$TpC(6P+2W+7)+65$	$TpC(3P+W+3)+TwCL+65$		360	ns
2	TdBR (BACK)	$\overline{BREQ} \uparrow$ to $\overline{BUSACK} \uparrow$	$3TpC+60$	$TpC+TwCL+60$		185	ns
3	TdBACK (BREL)	$\overline{BUSACK} \downarrow$ to Bus Release	20	20		20	ns
4	TdBACK (BACT)	$\overline{BUSACK} \uparrow$ to Bus Active	20	20		20	ns

Note: The value left hand two columns show the formula used to calculate the timing minimum or maximum from the oscillator clock period, prescale value and number of wait cycles inserted.
The value right hand two columns show the timing minimum and maximum for an external clock at 24MHz divided by 2, prescale value of zero and zero wait status.

BUS REQUEST/ACKNOWLEDGE TIMING

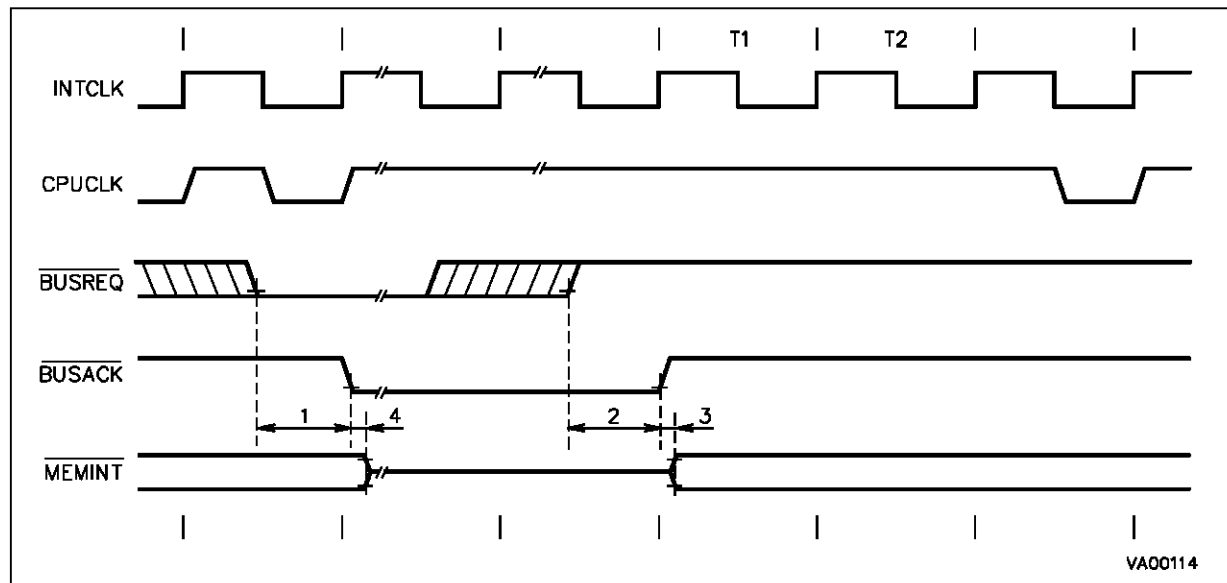

Note : MEMINT = Group of memory interface signals: AS, DS, R/W, P00-P07, P10-P17

EXTERNAL INTERRUPT TIMING TABLE ($V_{DD} = 5V \pm 10\%$, $T_A = -40^\circ\text{C}$ to $+85^\circ\text{C}$, $C_{load} = 50\text{pF}$, $\text{INTCLK} = 12\text{MHz}$, Push-pull output configuration, unless otherwise specified)

N°	Symbol	Parameter	Value (Note)				Unit
			OSCIN Divided By 2 Min.	OSCIN Not Divided By 2 Min.	Min.	Max.	
1	TwLR	Low Level Minimum Pulse Width in Rising Edge Mode	$2T_{pC}+12$	$T_{pC}+12$	95		ns
2	TwHR	High Level Minimum Pulse Width in Rising Edge Mode	$2T_{pC}+12$	$T_{pC}+12$	95		ns
3	TwHF	High Level Minimum Pulse Width in Falling Edge Mode	$2T_{pC}+12$	$T_{pC}+12$	95		ns
4	TwLF	Low Level Minimum Pulse Width in Falling Edge Mode	$2T_{pC}+12$	$T_{pC}+12$	95		ns

Note: The value left hand two columns show the formula used to calculate the timing minimum or maximum from the oscillator clock period, prescale value and number of wait cycles inserted.
 The value right hand two columns show the timing minimum and maximum for an external clock at 24 MHz divided by 2, prescale value of zero and zero wait status.

EXTERNAL INTERRUPT TIMING

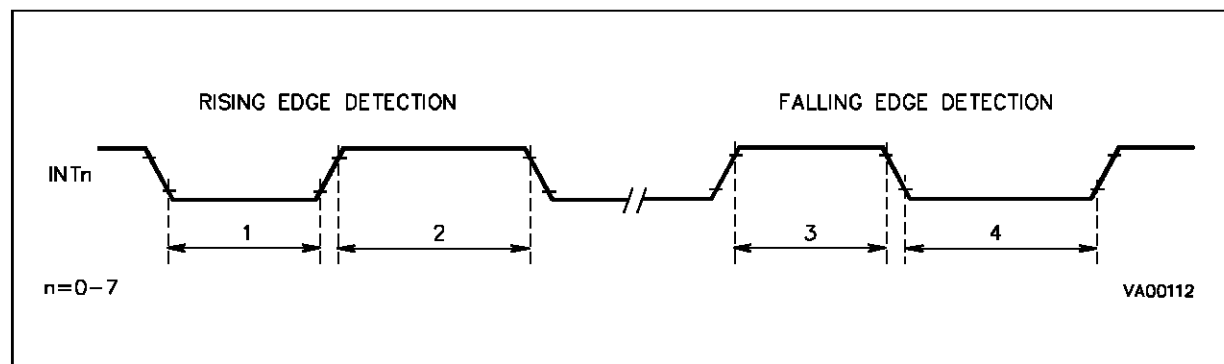

SPI TIMING TABLE ($V_{DD} = 5V \pm 10\%$, $T_A = -40^\circ\text{C}$ to $+85^\circ\text{C}$, $C_{load} = 50\text{pF}$, $\text{INTCLK} = 12\text{MHz}$,
Output Alternate Function set as Push-pull)

N°	Symbol	Parameter	Value		Unit
			Min.	Max.	
1	TsDI	Input Data Set-up Time	100		ns
2	ThDI (1)	Input Data Hold Time	$1/2 T_{pC} + 100$		ns
3	TdOV	SCK to Output Data Valid		100	ns
4	ThDO	Output Data Hold Time	-20		ns
5	TwSKL	SCK Low Pulse Width	300		ns
6	TwSKH	SCK High Pulse Width	300		ns

Note: T_{pC} is the OSCIN Clock period.

SPI TIMING

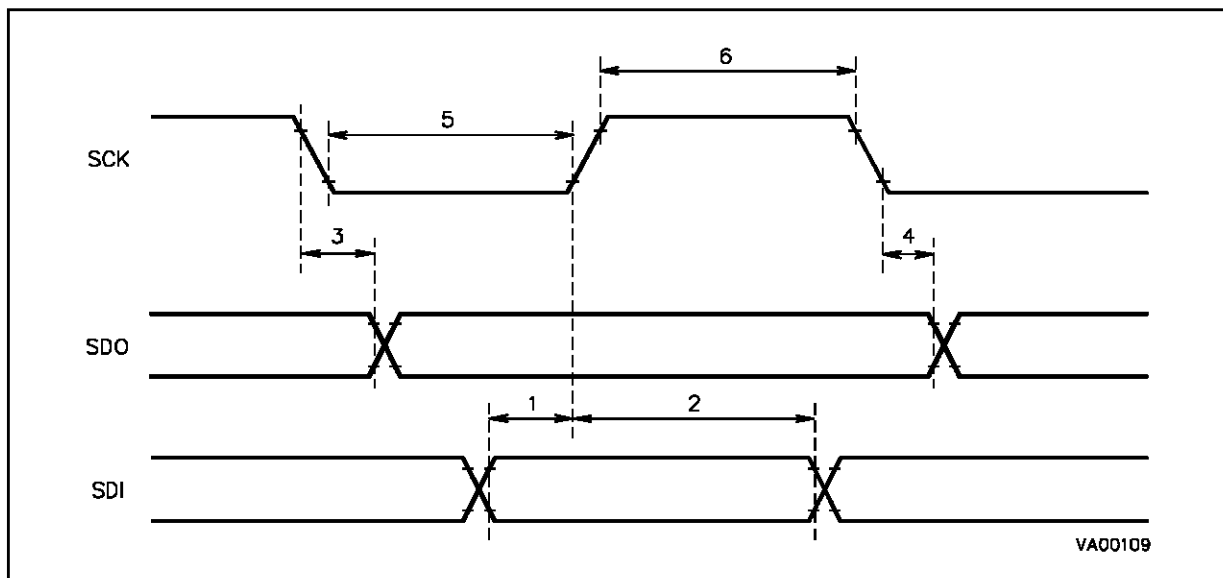

WATCHDOG TIMING TABLE ($V_{DD} = 5V \pm 10\%$, $T_A = -40^\circ C$ to $+85^\circ C$, $C_{load} = 50pF$, $CPUCLK = 12MHz$, Push-pull output configuration, unless otherwise specified)

N°	Symbol	Parameter	Values		Unit
			Min.	Max.	
1	T _w WDOL	WDOUT Low Pulse Width	620		ns
2	T _w WDOH	WDOUT High Pulse Width	620		ns
3	T _w WDIL	WDIN High Pulse Width	350		ns
4	T _w WDIH	WDIN Low Pulse Width	350		ns

WATCHDOG TIMING

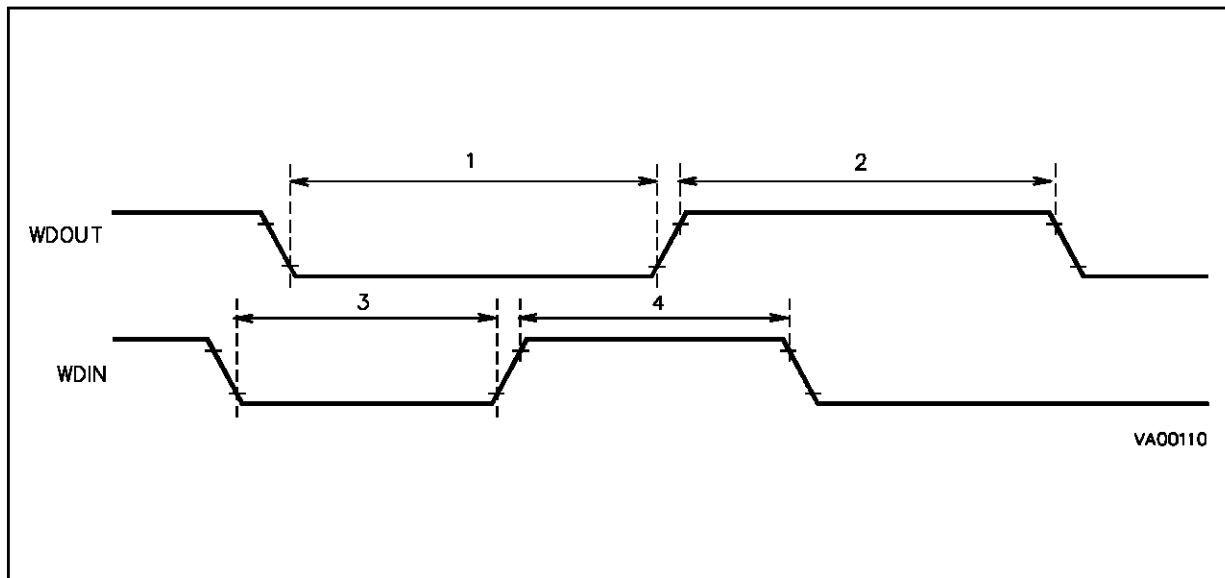

MULTIFUNCTION TIMER UNIT EXTERNAL TIMING

N°	Symbol	Parameter	OSCIN Divided by 2 (3)	OSCIN Not Divided by 2 (3)	Value (4)		Unit	Note
					Min.	Max.		
1	TWCTW	External clock/trigger pulse width	2n x Tpc	n x Tpc	n x 83	-	ns	1
2	TWCTD	External clock/trigger pulse distance	2n x Tpc	n x Tpc	n x 83	-	ns	1
3	TWAED	Distance between two active edges	6 x Tpc	3 x Tpc	249	-	ns	
4	TWGW	Gate pulse width	12 x Tpc	6 x Tpc	498	-	ns	
5	TWLBA	Distance between TINB pulse edge and the following TINA pulse edge	2 x Tpc	Tpc	83	-	ns	2
6	TWLAB	Distance between TINA pulse edge and the following TINB pulse edge	0		0	-	ns	2
7	TWAD	Distance between two TxINA pulses	0		0	-	ns	2
8	TWOWD	Minimum output pulse width/distance	6 x Tpc	3 x Tpc	249	-	ns	

Notes:

- n = 1 if the input is rising OR falling edge sensitive
n = 3 if the input is rising AND falling edge sensitive
- In Autodiscrimination mode
- Variable clock (Tpc = OSCIN period)
- INTCLK = 12 MHz

MULTIFUNCTION TIMER UNIT EXTERNAL TIMING

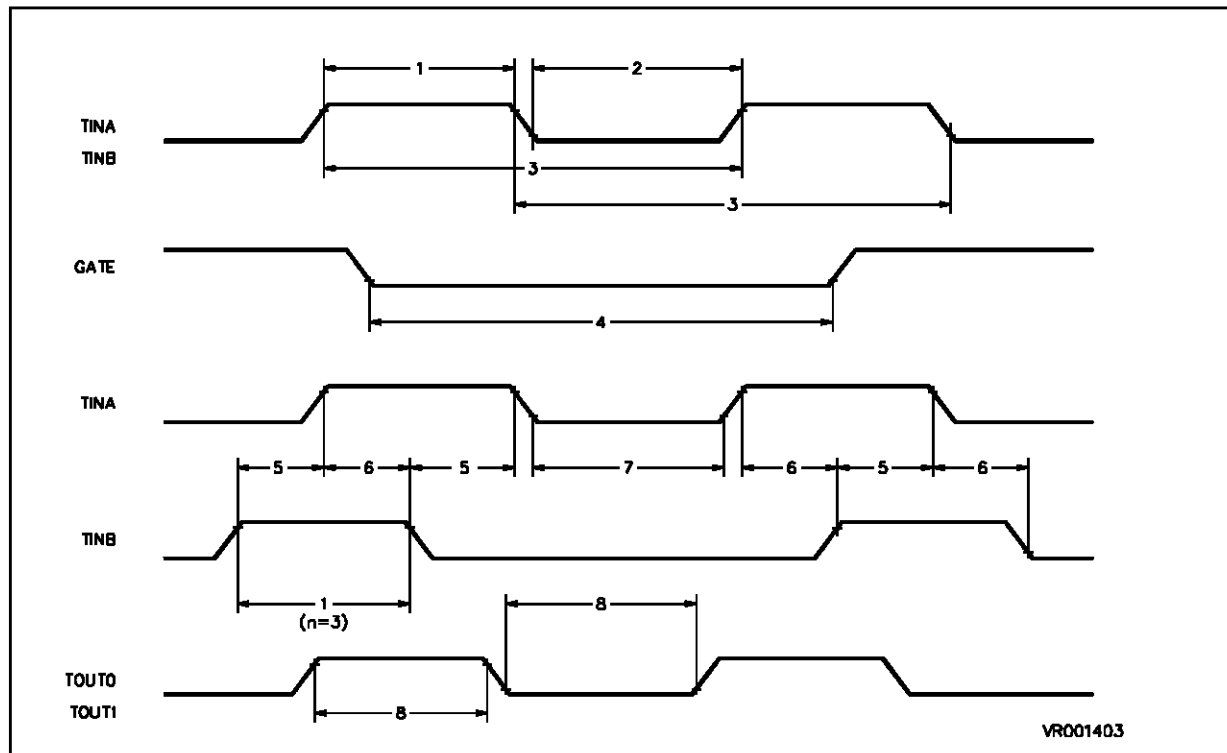

SCI TIMING TABLE ($V_{DD} = 5V \pm 10\%$, $T_A = -40\text{ }^\circ\text{C}$ to $+85\text{ }^\circ\text{C}$, $C_{load} = 50\text{pF}$, $INTCLK = 12\text{MHz}$, Output alternate function set as Push-pull)

N°	Symbol	Parameter	Condition	Value		Unit
				Min.	Max.	
	F_{RxCKIN}	Frequency of RxCKIN	1 x mode		$F_{CK}/8$	Hz
			16 x mode		$F_{CK}/4$	Hz
	$T_{WRxCKIN}$	RxCKIN shortest pulse	1 x mode	$4 T_{CK}$		s
			16 x mode	$2 T_{CK}$		s
	F_{TxCKIN}	Frequency of TxCKIN	1 x mode		$F_{CK}/8$	Hz
			16 x mode		$F_{CK}/4$	Hz
	$T_{WTxCKIN}$	TxCKIN shortest pulse	1 x mode	$4 T_{CK}$		s
			16 x mode	$2 T_{CK}$		s
1	T_{SDS}	DS (Data Stable) before rising edge of RxCKIN	1 x mode reception with RxCKIN	$T_{PC}/2$		ns
2	T_{d1}	TxCKIN to Data out delay Time	1 x mode transmission with external clock C load $<100\text{pF}$		$2.5 T_{PC}$	ns
3	T_{d2}	CLKOUT to Data out delay Time	1 x mode transmission with CLKOUT	350		ns

Note: $F_{CK} = 1/T_{CK}$

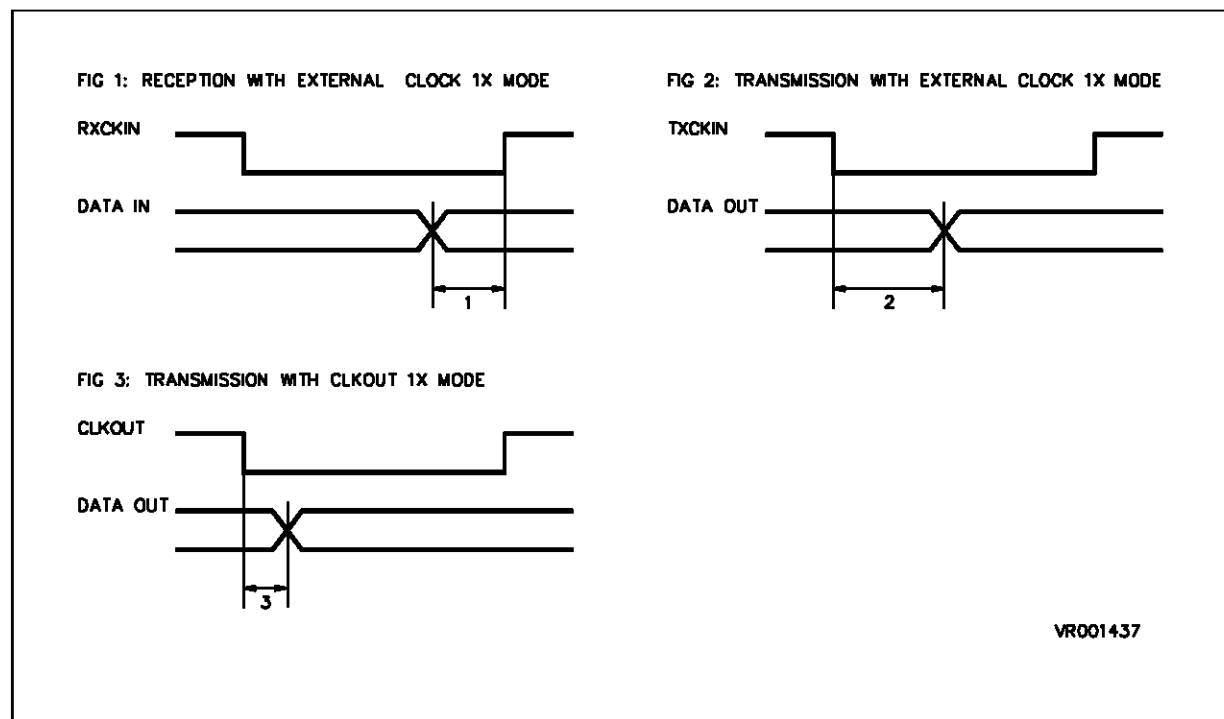

PACKAGE MECHANICAL DATA

40-Pin Plastic Dual In Line Package(B)

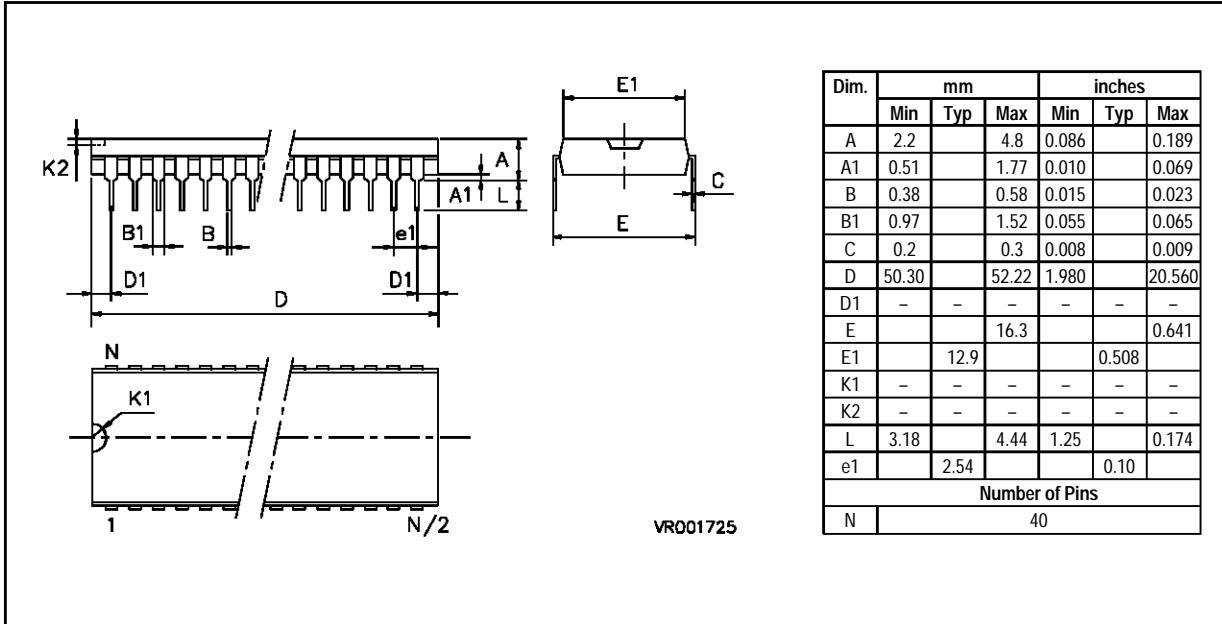

44-Lead Plastic Leaded Chip Carrier Package (C)

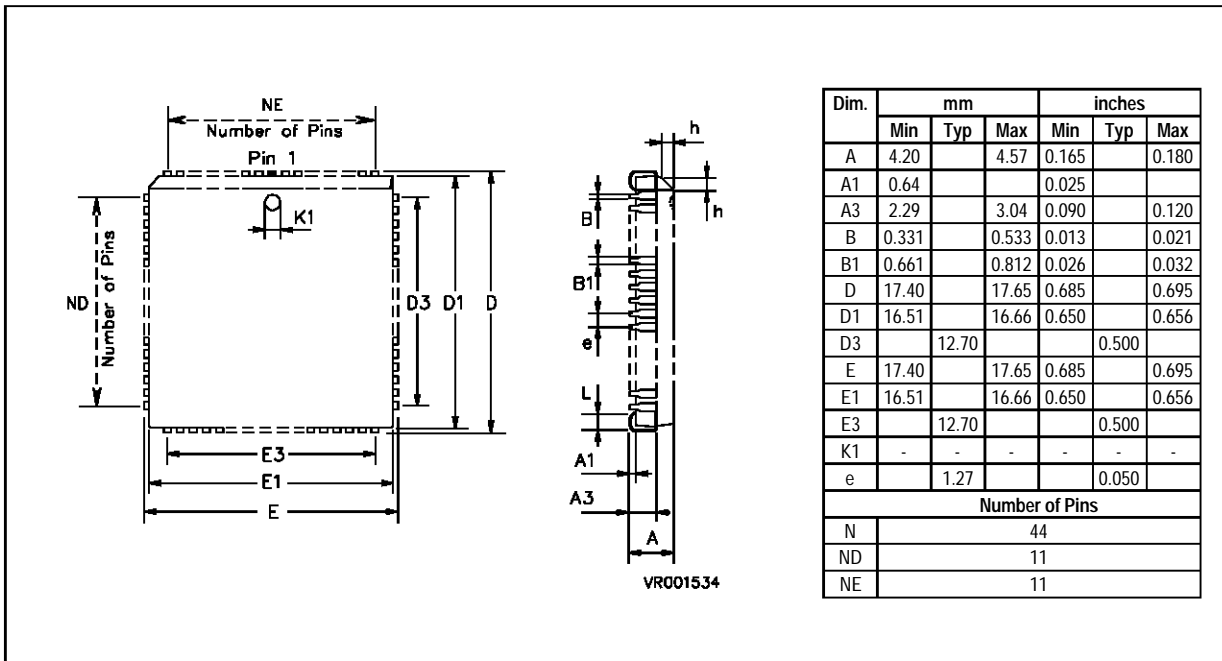

ST9020, 27, 28

56-Pin Plastic Dual In Line Package, 600 Mil Width

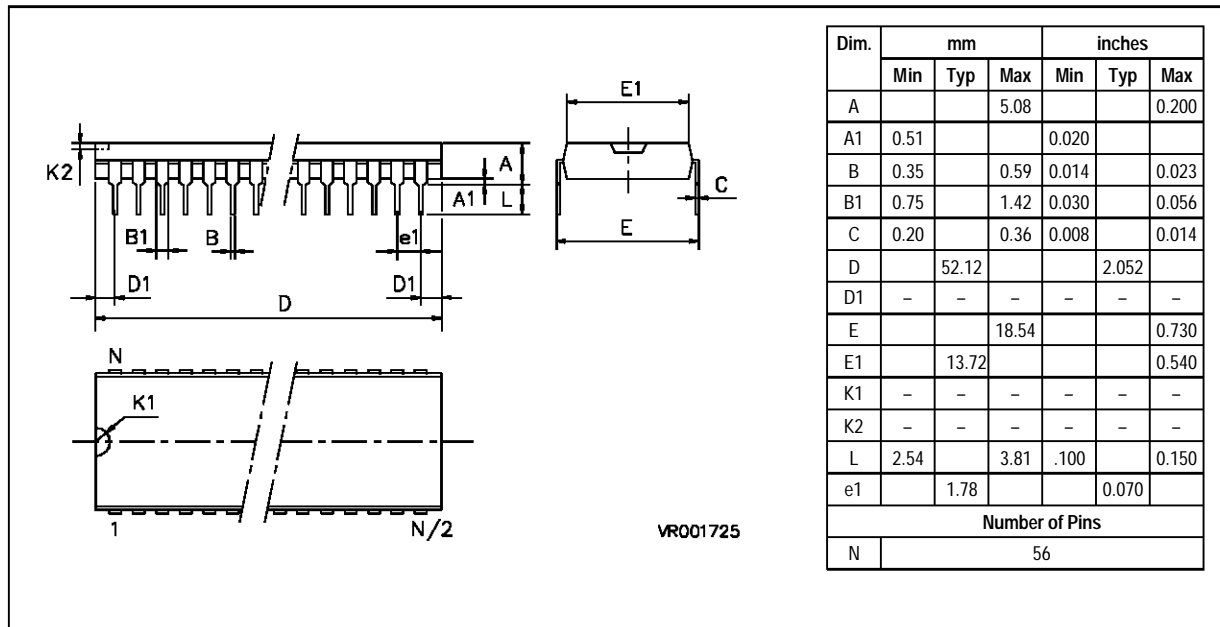

ORDERING INFORMATION

Sales Type	Frequency	Temperature Range	Package
ST9020B1/XX	24MHz	0°C to + 70°C	PDIP40
ST9027B1/XX	24MHz	0°C to + 70°C	PDIP40
ST9028C1/XX	24MHz	0°C to + 70°C	PLCC44
ST9028B1/XX	24MHz	0°C to + 70°C	SDIP56
ST9020B6/XX	24MHz	-40°C to + 85°C	PDIP40
ST9027B6/XX	24MHz	-40°C to + 85°C	PDIP40
ST9028C6/XX	24MHz	-40°C to + 85°C	PLCC44
ST9028B6/XX	24MHz	-40°C to + 85°C	SDIP56

Note: "XX" is the ROM code identifier that is allocated by SGS-THOMSON after receipt of all required options and the related ROM file.

ST9020, ST9027, ST9028 OPTION LIST

Please copy this page (enlarge if possible) and complete ALL sections.
Send the form, with the ROM code image required, to your local SGS-THOMSON sales office.

Customer Company : [.....]
Company Address : [.....]
[.....]
Telephone : [.....]
FAX : [.....]
Contact : [.....] Telephone (Direct) : [.....]

Please confirm device required :

[] ST9020 12K ROM PDIP40 [] ST9027 16K ROM 256 RAM PDIP40 [] ST9028 16K ROM 256 RAM PLCC44 [] ST9028 16K ROM 256 RAM PSDIP56

Temperature Range [] 0, +70°C [] -40°C, +85°C
Special Marking [] (Yes) 13 characters for ST 9020,27 [| | | | | | | | | | | |]
 [] (Yes) 11 characters for ST 9028 [| | | | | | | | | |]
 [] (No)

Note : 2Authorized characters are letters, digits, '.', '-', '/' and spaces only.
Please consult your local SGS-THOMSON sales office for other marking details if required.

Code : [] EPROM (27128, 27256)
 [] HEX format files on IBM-PC® compatible disk
 filename: [.....]

Confirmation : [] Code checked with EPROM device in application

Yearly Quantity forecast : [.....] k units
- for a period of : [.....] years

Preferred Production start dates : [.....] (YY/MM/DD)

Customer Signature :
Date :

Notes :

16K EPROM HCMOS MCUs WITH RAM

- Register oriented 8/16 bit CORE with RUN, WFI and HALT modes
- Minimum instruction cycle time: 500ns (12MHz internal)
- Internal Memory :
 - EPROM 16Kbytes
 - RAM 256bytes224 general purpose registers available as RAM, accumulators or index pointers (Register File)
- 40-lead Dual In Line Plastic Package for ST90T27.
- 40-lead Windowed Ceramic Dual In Line Package for ST90E27.
- 44-lead Plastic Leaded Chip Carrier Package for ST90T28C.
- 44-lead Windowed Ceramic Leaded Chip Carrier Package for ST90E28L
- 56-lead Dual In Line Plastic Package for ST90T28B.
- 56-lead Windowed Ceramic Dual In Line Package for ST90E28D.
- DMA controller, Interrupt handler and Serial Peripheral Interface as standard features
- Up to 40 fully programmable I/O pins
- Up to 8 external plus 1 non-maskable interrupts
- 16 bit Timer with 8 bit Prescaler, able to be used as a Watchdog Timer
- One 16 bit Multifunction Timer, with an 8 bit prescaler and 12 operating modes
- Serial Communications Interface with asynchronous and synchronous capability
- Rich Instruction Set and 14 Addressing modes
- Division-by-Zero trap generation
- Versatile Development tools, including assembler, linker, C-compiler, archiver, graphic oriented debugger and hardware emulators
- Real Time Operating System
- Compatible with ST9020 12K ROM and ST9027/28 16K ROM/256 RAM.

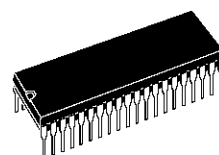

PDIP40

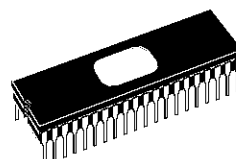

CDIP40-W

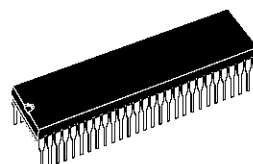

PSDIP56

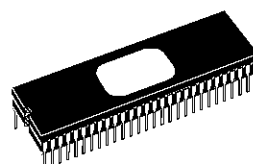

CSDIP56-W

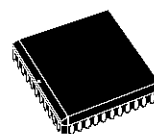

PLCC44

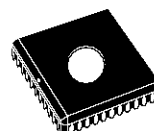

CLCC44-W

(Ordering Information at the end of the Datasheet)

ST90E27 - ST90E28

Figure 16-1. 40 Pin DIP Package

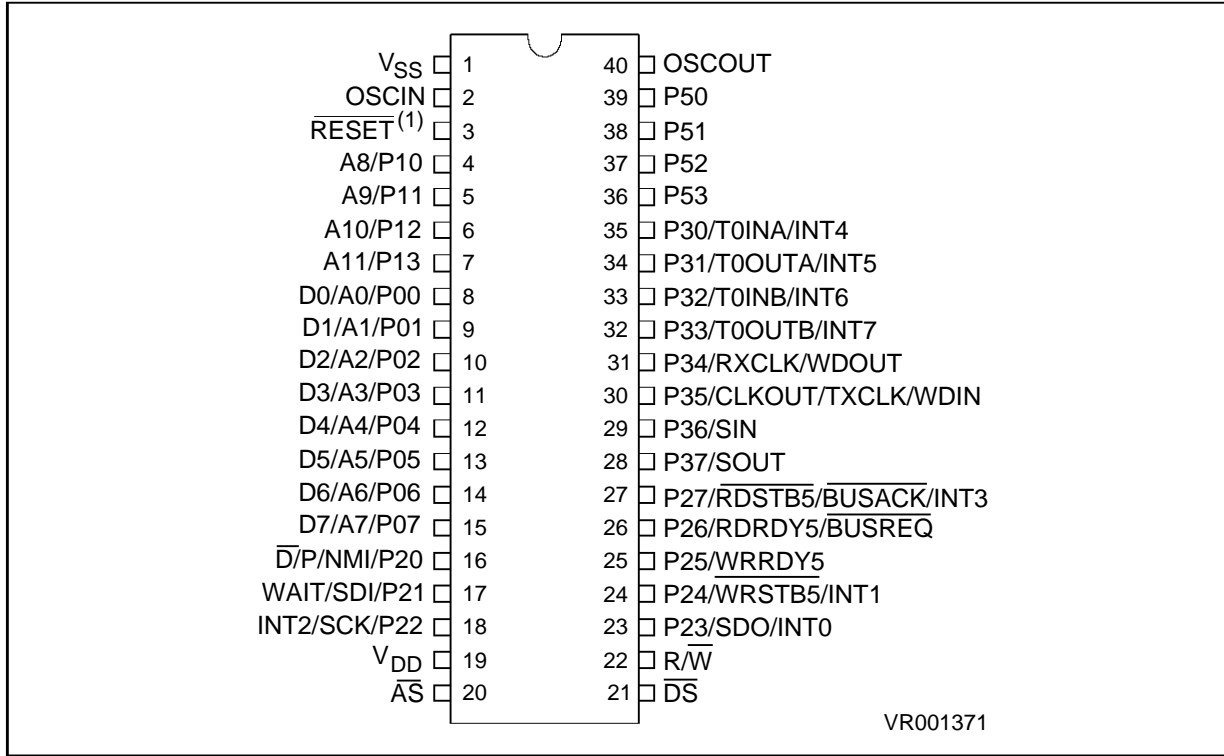

Note 1. This pin is also the VPP input for the EPROM based devices

Figure 16-2. 44 Pin PLCC Package

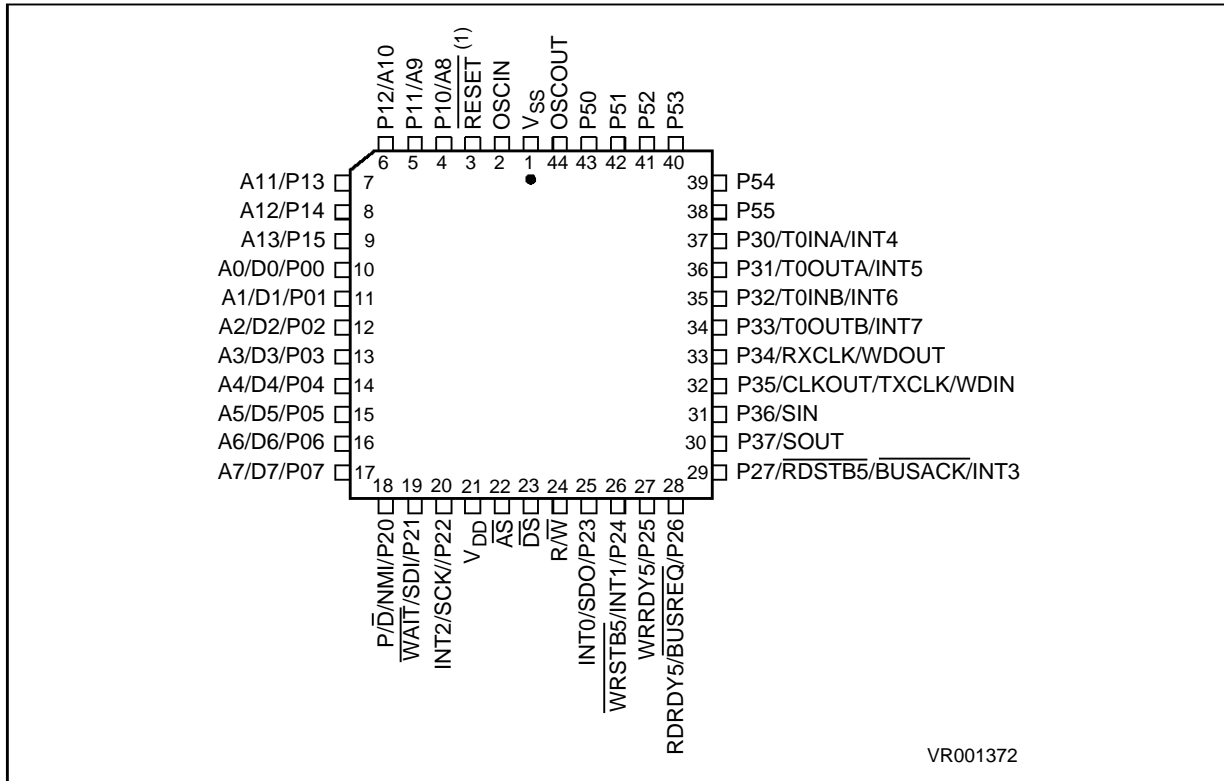

Note 1. This pin is also the VPP input for the EPROM based devices

Figure 16-3. 56 Pin DIP Package

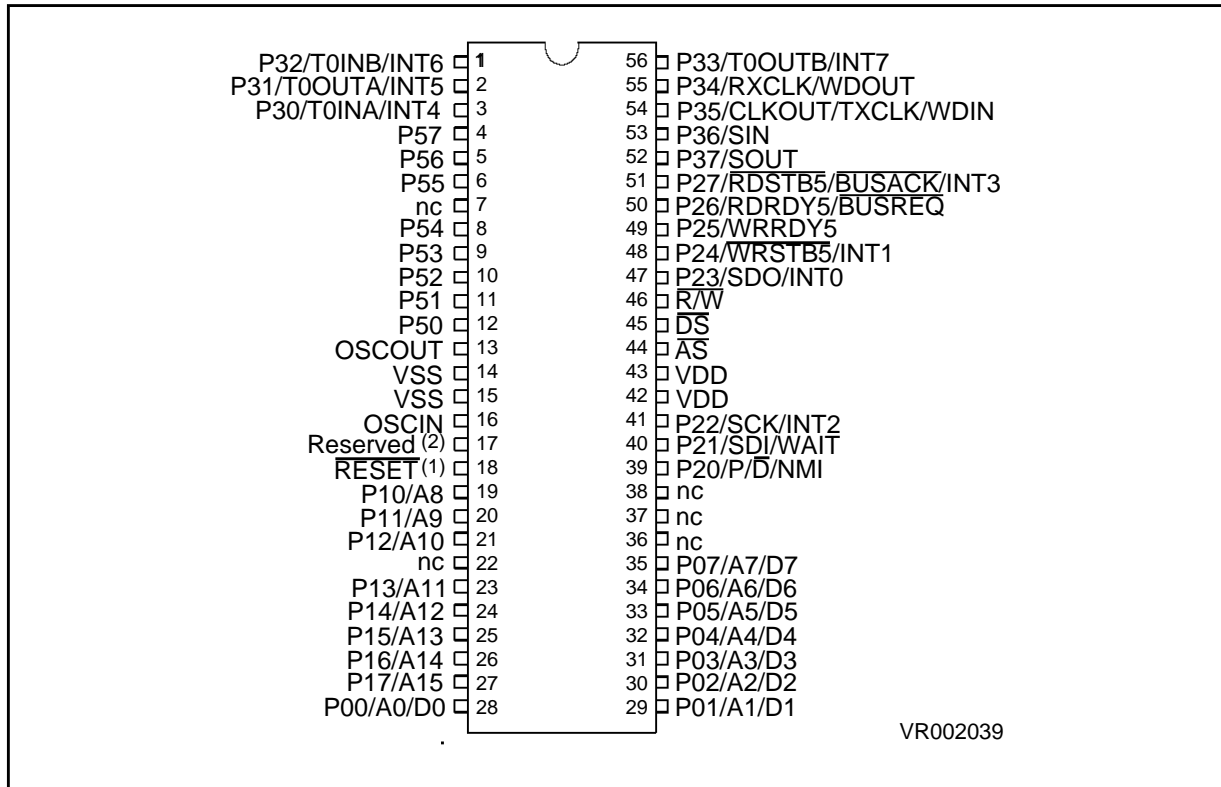

Note 1. This pin is also the VPP input for the EPROM based devices

16.1 GENERAL DESCRIPTION

The ST90E27, E28 and ST90T27, T28 (following mentioned as ST90E2x) are EPROM members of the ST9 family of microcontrollers, in windowed ceramic (E) and plastic OTP (T) packages respectively, completely developed and produced by SGS-THOMSON Microelectronics using a n-well proprietary HCMOS process.

The EPROM parts are fully compatible with their ROM versions and this datasheet will thus provide only information specific to the EPROM based devices.

THE READER IS ASKED TO REFER TO THE DATASHEET OF THE ST902x ROM-BASED DEVICE FOR FURTHER DETAILS.

The EPROM ST90E2x may be used for the prototyping and pre-production phases of development, and can be configured as: a standalone microcontroller with 16K bytes of on-chip ROM, a microcontroller able to manage external memory, or as a parallel processing element in a system with other processors and peripheral controllers.

The nucleus of the modular design of the ST902X is the advanced Core which includes the Central Processing Unit (CPU), the Register File, a 16 bit Timer/Watchdog with 8 bit Prescaler, a Serial Peripheral Interface supporting S-bus, I²C-bus and IM-bus Interface, plus two 8 bit I/O ports. The Core has independent memory and register buses allowing a high degree of pipelining to add to the efficiency of the code execution speed of the extensive instruction set.

The powerful I/O capabilities demanded by microcontroller applications are fulfilled by the ST902X with up to 40 I/O lines dedicated to digital Input/Output. These lines are grouped into up to three 8-bit and two 4/6/8-bit I/O Ports and can be configured on a bit basis under software control to provide timing, status signals, an address/data bus for interfacing external memory, timer inputs and outputs, external interrupts and serial or parallel I/O with or without handshake.

Figure 16-4. ST90E27, E28 Block Diagram

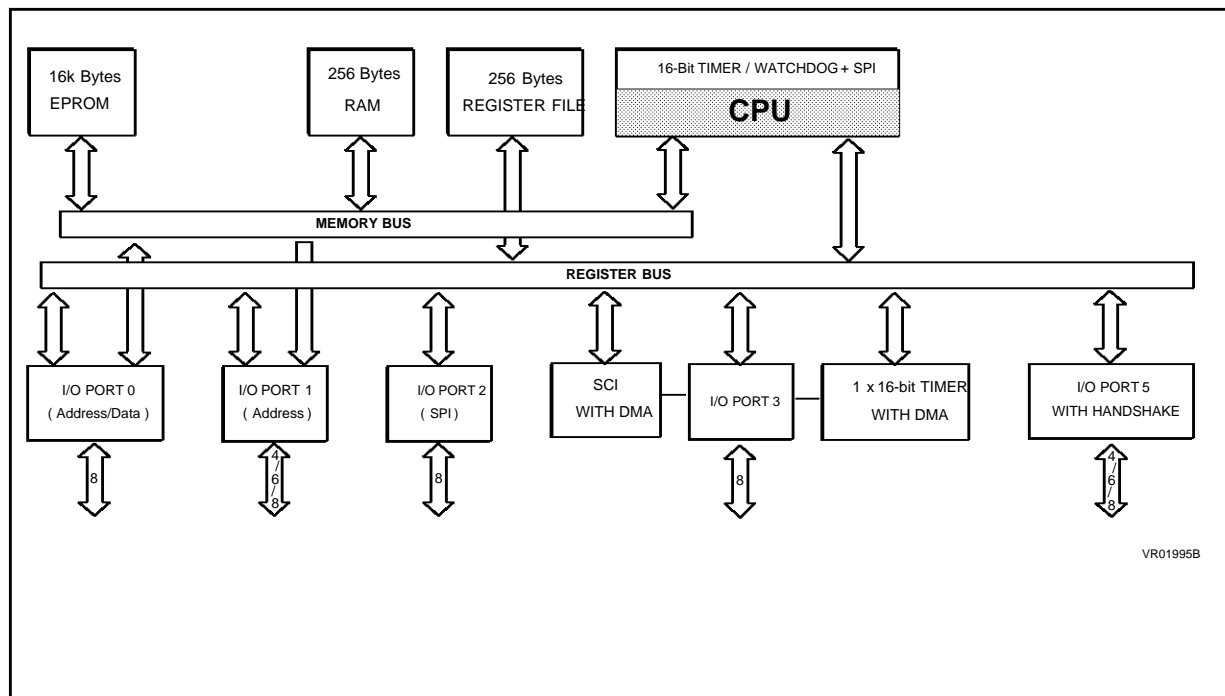

GENERAL DESCRIPTION (Continued)

Three basic memory spaces are available to support this wide range of configurations: Program Memory (internal and external), Data Memory (external) and the Register File, which includes the control and status registers of the on-chip peripherals.

The 16 bit MultiFunction Timer, with an 8 bit Prescaler and 12 operating modes allows simple use for complex waveform generation and measure-

ment, PWM functions and many other system timing functions by the usage of the two associated DMA channels for each timer.

Completing the device is a full duplex Serial Communications Interface with an integral 110 to 375000 baud rate generator, asynchronous and byte synchronous capability (fully programmable format) and associated address/wake-up option, plus two DMA channels.

16.2 PIN DESCRIPTION

\overline{AS} . *Address Strobe (output, active low, 3-state).* Address Strobe is pulsed low once at the beginning of each memory cycle. The rising edge of \overline{AS} indicates that address, Read/Write (R/\overline{W}), and Data Memory signals are valid for program or data memory transfers. Under program control, \overline{AS} can be placed in a high-impedance state along with Port 0 and Port 1, Data Strobe (\overline{DS}) and R/\overline{W} .

\overline{DS} . *Data Strobe (output, active low, 3-state).* Data Strobe provides the timing for data movement to or from Port 0 for each memory transfer. During a write cycle, data out is valid at the leading edge of \overline{DS} . During a read cycle, Data In must be valid prior to the trailing edge of \overline{DS} . When the ST902x accesses on-chip memory, \overline{DS} is held high during the whole memory cycle. It can be placed in a high impedance state along with Port 0, Port 1, \overline{AS} and R/\overline{W} .

R/\overline{W} . *Read/Write (output, 3-state).* Read/Write determines the direction of data transfer for external memory transactions. R/\overline{W} is low when writing to external program or data memory, and high for all other transactions. It can be placed in a high impedance state along with Port 0, Port 1, \overline{AS} and \overline{DS} .

\overline{RESET}/V_{PP} . *Reset (input, active low) or V_{PP} (input).* The ST9 is initialised by the Reset signal. With the deactivation of \overline{RESET} , program execution begins from the Program memory location

pointed to by the vector contained in program memory locations 00h and 01h. In the EPROM programming Mode, this pin acts as the programming voltage input V_{PP} .

OSCIN, OSCOUT. *Oscillator (input and output).* These pins connect a parallel-resonant crystal (24MHz maximum), or an external source to the on-chip clock oscillator and buffer. OSCIN is the input of the oscillator inverter and internal clock generator; OSCOUT is the output of the oscillator inverter.

V_{DD} . Main Power Supply Voltage ($5V \pm 10\%$)

V_{SS} . Digital Circuit Ground.

P0.0-P0.7, P1.0-P1.7, P2.0-P2.7 P3.0-P3.7, P5.0-P5.7 *I/O Port Lines (Input/Output, TTL or CMOS compatible).* 40 lines grouped into I/O ports of 4/6/8 bits, bit programmable under program control as general purpose I/O or as alternate functions.

16.3 I/O PORT ALTERNATE FUNCTIONS

Each pin of the I/O ports of the ST902x may assume software programmable Alternative Functions as shown in the Pin Configuration Drawings. Table 16-1 shows the Functions allocated to each I/O Port pins and a summary of packages for which they are available.

ST90E27 - ST90E28

PIN DESCRIPTION (Continued)

Table 16-1. ST902x I/O Port Alternate Function Summary

I/O PORT	Name	Function	Alternate Function	Pin Assignment		
				SDIP56	PDIP40	PLCC44
P0.0	A0/D0	I/O	Address/Data bit 0 mux	28	8	10
P0.1	A1/D1	I/O	Address/Data bit 1 mux	29	9	11
P0.2	A2/D2	I/O	Address/Data bit 2 mux	30	10	12
P0.3	A3/D3	I/O	Address/Data bit 3 mux	31	11	13
P0.4	A4/D4	I/O	Address/Data bit 4 mux	32	12	14
P0.5	A5/D5	I/O	Address/Data bit 5 mux	33	13	15
P0.6	A6/D6	I/O	Address/Data bit 6 mux	34	14	16
P0.7	A7/D7	I/O	Address/Data bit 7 mux	35	15	17
P1.0	A8	O	Address bit 8	19	4	4
P1.1	A9	O	Address bit 9	20	5	5
P1.2	A10	O	Address bit 10	21	6	6
P1.3	A11	O	Address bit 11	23	7	7
P1.4	A12	O	Address bit 12	24	-	8
P1.5	A13	O	Address bit 13	25	-	9
P1.6	A14	O	Address bit 14	26	-	-
P1.7	A15	O	Address bit 15	27	-	-
P2.0	NMI	I	Non-Maskable Interrupt	39	16	18
P2.0	P/\overline{D}	O	Program/Data Space Select	39	16	18
P2.1	SDI	I	SPI Serial Data In	40	17	19
P2.1	\overline{WAIT}	I	External Wait Input	40	17	19
P2.2	INT2	I	External Interrupt 2	41	18	20
P2.2	SCK	O	SPI Serial Clock	41	18	20
P2.3	INT0	I	External Interrupt 0	47	23	25
P2.3	SDO	O	SPI Serial Data Out	47	23	25
P2.4	INT1	I	External Interrupt 1	48	24	26
P2.4	$\overline{WRSTB5}$	I	Handshake Write Strobe P5	48	24	26
P2.5	WRRDY5	O	Handshake Write Ready P5	49	25	27
P2.6	RDRDY5	O	Handshake Read Ready P5	50	26	28

PIN DESCRIPTION (Continued)

Table 16-1. ST902x I/O Port Alternate Function Summary

I/O PORT	Name	Function	Alternate Function	Pin Assignment		
				SDIP56	PDIP40	PLCC44
Port.bit						
P2.6	$\overline{\text{BUSREQ}}$	I	External Bus Request	50	26	28
P2.7	INT3	I	External Interrupt 1	51	27	29
P2.7	$\overline{\text{RDSTB5}}$	I	Handshake Read Strobe P5	51	27	29
P2.7	$\overline{\text{BUSACK}}$	O	External Bus Acknowledge	51	27	29
P3.0	INT4	I	External Interrupt 4	3	35	37
P3.0	T0INA	I	MF Timer 0 Input A	3	35	37
P3.1	INT5	I	External Interrupt 5	2	34	36
P3.1	T0OUTA	O	MF Timer 0 Output A	2	34	36
P3.2	INT6	I	External Interrupt 6	1	33	35
P3.2	T0INB	I	MF Timer 0 Input B	1	33	35
P3.3	INT7	I	External Interrupt 7	56	32	34
P3.3	T0OUTB	O	MF Timer 0 Output B	56	32	34
P3.4	RXCLK	I	SCI Receive Clock Input	55	31	33
P3.4	WDOUT	O	T/WD Output	55	31	33
P3.5	CLKOUT	O	SCI Byte Sync Clock Output	54	30	32
P3.5	TXCLK	I	SCI Transmit Clock Input	54	30	32
P3.5	WDIN	I	T/WD Input	54	30	32
P3.6	SIN	I	SCI Serial Input	53	29	31
P3.7	SOUT	O	SCI Serial Output	52	28	30
P5.0		O	I/O Handshake Port 5	12	39	43
P5.1		O	I/O Handshake Port 5	11	38	42
P5.2		O	I/O Handshake Port 5	10	37	41
P5.3		O	I/O Handshake Port 5	9	36	40
P5.4		O	I/O Handshake Port 5	8	-	39
P5.5		O	I/O Handshake Port 5	6	-	38
P5.6		O	I/O Handshake Port 6	5	-	-
P5.7		O	I/O Handshake Port 7	4	-	-

16.4 MEMORY

The memory of the ST90E2x is functionally divided into two areas, the Register File and Memory. The Memory is divided into two spaces, each having a maximum of 64K bytes. The two memory spaces are separated by function, one space for Program code, the other for Data. The ST90E2x 16K bytes of on-chip EPROM memory are selected at memory addresses 0 through 3FFFh (hexadecimal) in the PROGRAM space, while the ST90T2x OTP version has the top 64 bytes of the EPROM reserved by SGS-THOMSON for testing purposes. The DATA space includes the 256 bytes of on-chip RAM memory at memory addresses 0000h through 00FFh.

WARNING. The ST90T2x has its 64 upper bytes in the internal EPROM reserved for testing purpose.

External data memory may be addressed using the multiplexed address and data buses (Alternate Functions of Ports 0 and 1). Additional Data Memory may be decoded externally by using the P/D Alternate Function output. The on-chip general purpose (GP) Registers may also be used as RAM memory for minimum chip count systems.

16.5 EPROM PROGRAMMING

The 16384 bytes of EPROM memory of the ST90E2x (16320 for the ST90T2x) may be programmed by using the EPROM Programming Boards (EPB) available from SGS-THOMSON.

16.5.1 Eprom Erasing

The EPROM of the windowed package of the ST90E2x may be erased by exposure to Ultra-Violet light.

The erasure characteristic of the ST90E2x is such that erasure begins when the memory is exposed to light with a wave lengths shorter than approximately 4000Å. It should be noted that sunlight and some types of fluorescent lamps have wave-lengths in the range 3000-4000Å. It is thus recommended that the window of the ST90E2x packages be covered by an opaque label to prevent unintentional erasure problems when testing the application in such an environment.

The recommended erasure procedure of the EPROM is the exposure to short wave ultraviolet light which have a wave-length 2537Å. The integrated dose (i.e. U.V. intensity x exposure time) for erasure should be a minimum of 15W-sec/cm². The erasure time with this dosage is approximately 15 to 20 minutes using an ultraviolet lamp with 12000µW/cm² power rating. The ST90E2x should be placed within 2.5cm (1Inch) of the lamp tubes during erasure.

Figure 16-5. Memory Spaces

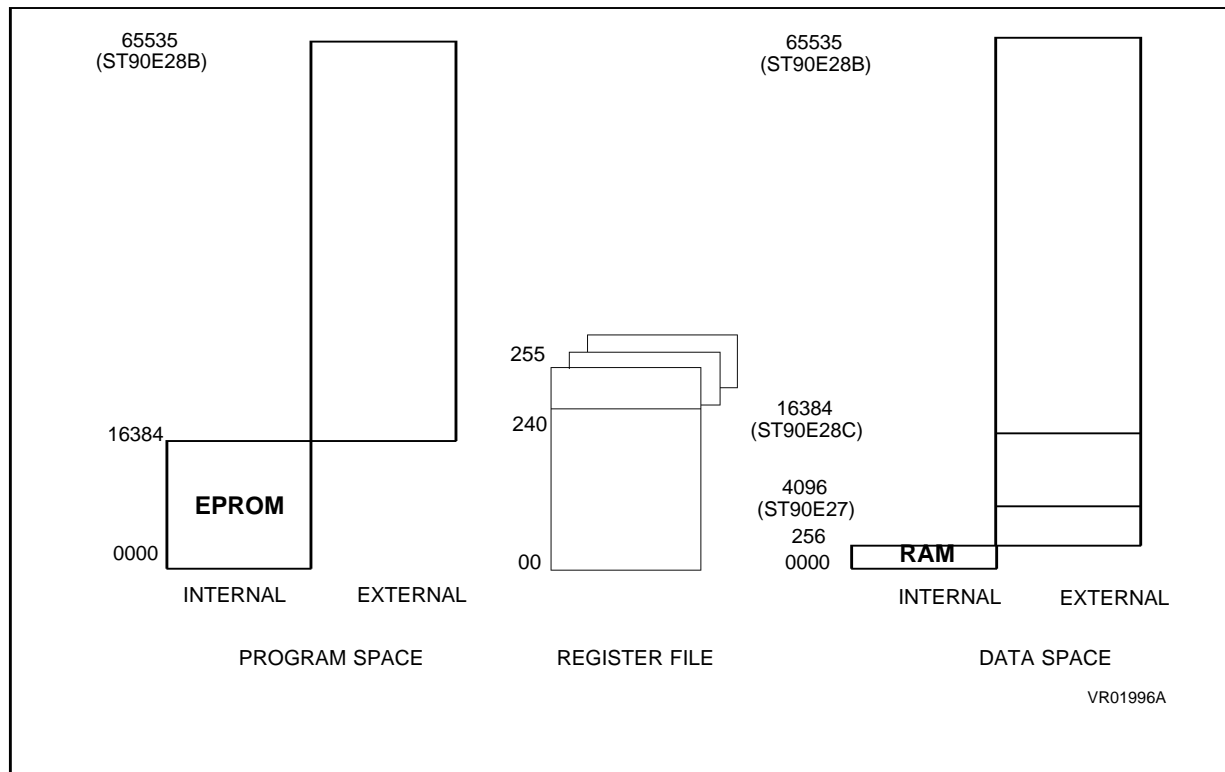

ABSOLUTE MAXIMUM RATINGS

Symbol	Parameter	Value	Unit
V _{DD}	Supply Voltage	- 0.3 to 7.0	V
V _I	Input Voltage	- 0.3 to V _{DD} + 0.3	V
V _O	Output Voltage	- 0.3 to V _{DD} + 0.3	V
V _{PP}	Input Voltage on V _{PP} Pin	-0.3 to 13.5	V
T _{STG}	Storage Temperature	-55 to + 150	°C
I _{INJ}	Pin Injection Current Digital	-5 to 5	mA
	Maximum accumulated pin injection Current in the device	-50 to 50	mA

Note: Stresses above those listed as “absolute maximum ratings” may cause permanent damage to the device. This is a stress rating only and functional operation of the device at these conditions is not implied. Exposure to maximum rating conditions for extended periods may affect device reliability. All voltages are referenced to V_{SS}

RECOMMENDED OPERATING CONDITIONS

Symbol	Parameter	Value		Unit
		Min.	Max.	
T _A	Operating Temperature	- 40	85	°C
V _{DD}	Operating Supply Voltage	4.5	5.5	V
f _{OSCE}	External Oscillator Frequency		24	MHz
f _{OSCI}	Internal Clock Frequency (INTCLK)		12	MHz

DC ELECTRICAL CHARACTERISTICS

V_{DD} = 5V ± 10% T_A = - 40°C to + 85°C, unless otherwise specified)

Symbol	Parameter	Test Conditions	Value			Unit
			Min.	Typ.	Max.	
V _{IHCK}	Clock Input High Level	External Clock	0.7 V _{DD}		V _{DD} + 0.3	V
V _{ILCK}	Clock Input Low Level	External Clock	- 0.3		0.3 V _{DD}	V
V _{IH}	Input High Level	TTL	2.0		V _{DD} + 0.3	V
		CMOS	0.7 V _{DD}		V _{DD} + 0.3	V
V _{IL}	Input Low Level	TTL	- 0.3		0.8	V
		CMOS	- 0.3		0.3 V _{DD}	V
V _{IHRS}	$\overline{\text{RESET}}$ Input High Level		0.7 V _{DD}		V _{DD} + 0.3	V
V _{ILRS}	$\overline{\text{RESET}}$ Input Low Level		-0.3		0.3 V _{DD}	V
V _{HYRS}	$\overline{\text{RESET}}$ Input Hysteresis		0.3		1.5	V
V _{OH}	Output High Level	Push Pull, I _{load} = - 0.8mA	V _{DD} - 0.8			V
V _{OL}	Output Low Level	Push Pull or Open Drain, I _{load} = 1.6mA			0.4	V

ST90E27 - ST90E28

DC ELECTRICAL CHARACTERISTICS (continued)

Symbol	Parameter	Test Conditions	Value			Unit
			Min.	Typ.	Max.	
I_{WPU}	Weak Pull-up Current	Bidirectional Weak Pull-up, $V_{OL} = 0V$	- 50	- 200	- 420	μA
I_{APU}	Active Pull-up Current, for INT0 and INT7 only	$V_{IN} < 0.8V$, under Reset	- 80	- 200	- 420	μA
I_{LKIO}	I/O Pin Input Leakage	Input/Tri-State, $0V < V_{IN} < V_{DD}$	- 10		+ 10	μA
I_{LKRS}	Reset Pin Input Leakage	$0V < V_{IN} < V_{DD}$	- 30		+ 30	μA
I_{LKAP}	Active Pull-up Input Leakage	$0V < V_{IN} < 0.8V$	- 10		+ 10	μA
I_{LKOS}	OSCIN Pin Input Leakage	$0V < V_{IN} < V_{DD}$	- 10		+ 10	μA
V_{PP}	EPROM Programming Voltage		12.2	12.5	12.8	V
I_{PP}	EPROM Programming Current				30	mA

Note:

1. All I/O Ports are configured in Bidirectional Weak Pull-up Mode with no DC load, External Clock pin (OSCIN) is driven by square wave external clock. No peripheral working.

DC TEST CONDITIONS

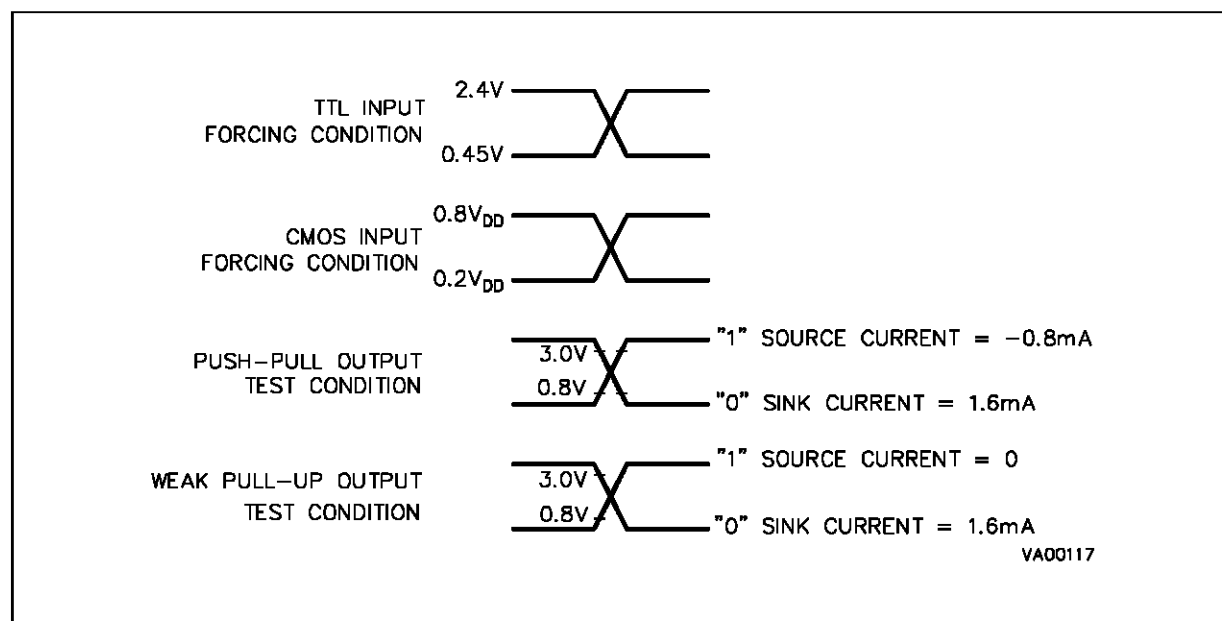

AC ELECTRICAL CHARACTERISTICS(V_{DD} = 5V ± 10% T_A = – 40°C to + 85°C, unless otherwise specified)

Symbol	Parameter	Test Conditions	Value			Unit
			Min.	Typ.	Max.	
I _{DD}	Run Mode Current no CPUCLK prescale, Clock divide by 2	24MHz 4MHz			40	mA
I _{DP2}	Run Mode Current Prescale by 2 Clock divide by 2	24MHz 4MHz			25 8	mA
I _{WFI}	WFI Mode Current no CPUCLK prescale, Clock divide by 2	24MHz 4MHz			15 5	mA
I _{HALT}	HALT Mode Current	24MHz			10	μA

ST90E27 - ST90E28

CLOCK TIMING TABLE

($V_{DD} = 5V \pm 10\%$, $T_A = -40^{\circ}C$ to $+85^{\circ}C$)

N°	Symbol	Parameter	Value		Unit	Note
			Min.	Max.		
1	TpC	OSCIN Clock Period	41.5		ns	1
			83		ns	2
2	TrC, TfC	OSCIN Rise and Fall Time		12	ns	
3	TwCL, TwCH	OSCIN Low and High Width	17	25	ns	1
			38		ns	2

Notes:

1. Clock divided by 2 internally (MODER.DIV2=1)
2. Clock not divided by 2 internally (MODER.DIV2=0)

CLOCK TIMING

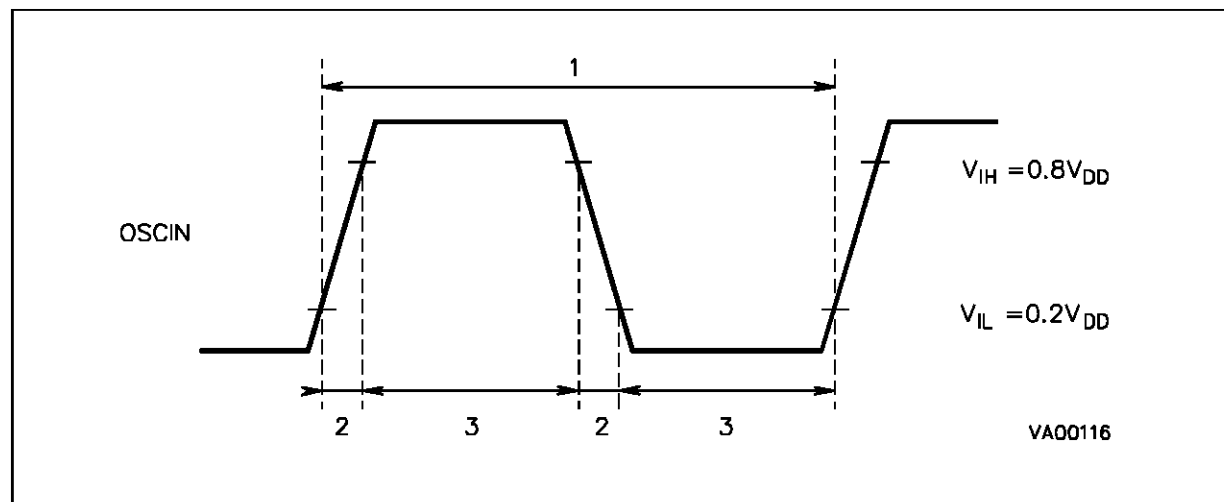

EXTERNAL BUS TIMING TABLE ($V_{DD} = 5V \pm 10\%$, $T_A = -40^\circ\text{C}$ to $+85^\circ\text{C}$, $C_{load} = 50\text{pF}$, $\text{CPUCLK} = 12\text{MHz}$, unless otherwise specified)

N°	Symbol	Parameter	Value (Note)				Unit
			OSCIN Divided By 2	OSCIN Not Divided By 2	Min.	Max.	
1	TsA (AS)	Address Set-up Time before $\overline{\text{AS}} \uparrow$	$T_{pC} (2P+1) - 22$	$T_{WCH} + T_{pC} - 18$	20		ns
2	ThAS (A)	Address Hold Time after $\overline{\text{AS}} \uparrow$	$T_{pC} - 17$	$T_{wCL} - 13$	25		ns
3	TdAS (DR)	$\overline{\text{AS}} \uparrow$ to Data Available (read)	$T_{pC} (4P+2W+4) - 52$	$T_{pC} (2P+W+2) - 51$		115	ns
4	TwAS	$\overline{\text{AS}}$ Low Pulse Width	$T_{pC} (2P+1) - 7$	$T_{wCH} + T_{pC} - 3$	35		ns
5	TdAz (DS)	$\overline{\text{DS}} \downarrow$ to Address Float			12		ns
6	TwDSR	$\overline{\text{DS}}$ Low Pulse Width (read)	$T_{pC} (4P+2W+3) - 20$	$T_{wCH} + T_{pC} (2P+W+1) - 16$	105		ns
7	TwDSW	$\overline{\text{DS}}$ Low Pulse Width (write)	$T_{pC} (2P+2W+2) - 13$	$T_{pC} (P+W+1) - 13$	70		ns
8	TdDSR (DR)	$\overline{\text{DS}} \downarrow$ to Data Valid Delay (read)	$T_{pC} (4P+2W-3) - 50$	$T_{wCH} + T_{pC} (2P+W+1) - 46$		75	ns
9	ThDR (DS)	Data to $\overline{\text{DS}} \uparrow$ Hold Time (read)	0	0	0		ns
10	TdDS (A)	$\overline{\text{DS}} \uparrow$ to Address Active Delay	$T_{pC} - 7$	$T_{wCL} - 3$	35		ns
11	TdDS (AS)	$\overline{\text{DS}} \uparrow$ to $\overline{\text{AS}} \downarrow$ Delay	$T_{pC} - 18$	$T_{wCL} - 14$	24		ns
12	TsR/W (AS)	R/W Set-up Time before $\overline{\text{AS}} \uparrow$	$T_{pC} (2P+1) - 22$	$T_{wCH} + T_{pC} - 18$	20		ns
13	TdDSR (R/W)	$\overline{\text{DS}} \uparrow$ to R/W and Address Not Valid Delay	$T_{pC} - 9$	$T_{wCL} - 5$	33		ns
14	TdDW (DSW)	Write Data Valid to $\overline{\text{DS}} \downarrow$ Delay (write)	$T_{pC} (2P+1) - 32$	$T_{wCH} + T_{pC} - 28$	10		ns
15	ThDS (DW)	Data Hold Time after $\overline{\text{DS}} \uparrow$ (write)	$T_{pC} - 9$	$T_{wCL} - 5$	33		ns
16	TdA (DR)	Address Valid to Data Valid Delay (read)	$T_{pC} (6P+2W+5) - 68$	$T_{wCH} + T_{pC} (3P+W+2) - 64$		140	ns
17	TdAs (DS)	$\overline{\text{AS}} \uparrow$ to $\overline{\text{DS}} \downarrow$ Delay	$T_{pC} - 18$	$T_{wCL} - 14$	24		ns

EXTERNAL WAIT TIMING TABLE ($V_{DD} = 5V \pm 10\%$, $T_A = -40^\circ\text{C}$ to $+85^\circ\text{C}$, $C_{load} = 50\text{pF}$, $\text{INTCLK} = 12\text{MHz}$, Push-pull output configuration, unless otherwise specified)

N°	Symbol	Parameter	Value (Note)				Unit
			OSCIN Divided By 2	OSCIN Not Divided By 2	Min.	Max.	
1	TdAs (WAIT)	$\overline{\text{AS}} \uparrow$ to $\overline{\text{WAIT}} \downarrow$ Delay	$2(P+1)T_{pC} - 29$	$2(P+1)T_{pC} - 29$		40	ns
2	TdAs (WAIT)	$\overline{\text{AS}} \uparrow$ to $\overline{\text{WAIT}} \downarrow$ Min. Delay	$2(P+W+1)T_{pC} - 4$	$2(P+W+1)T_{pC} - 4$	80		ns
3	TdAs (WAIT)	$\overline{\text{AS}} \uparrow$ to $\overline{\text{WAIT}} \downarrow$ Max. Delay	$2(P+W+1)T_{pC} - 29$	$2(P+W+1)T_{pC} - 29$		$83W + 40$	ns

Note: (for both table) The value in the left hand two columns show the formula used to calculate the timing minimum or maximum from the oscillator clock period, prescale value and number of wait cycles inserted. The value in the right hand two columns show the timing minimum and maximum for an external clock at 24 MHz divided by 2, prescaler value of zero and zero wait status.

Legend:

P = Clock Prescaling Value
W = Wait Cycles

T_{pC} = OSCIN Period
 T_{wCH} = High Level OSCIN half period
 T_{wCL} = Low Level OSCIN half period

EXTERNAL BUS TIMING

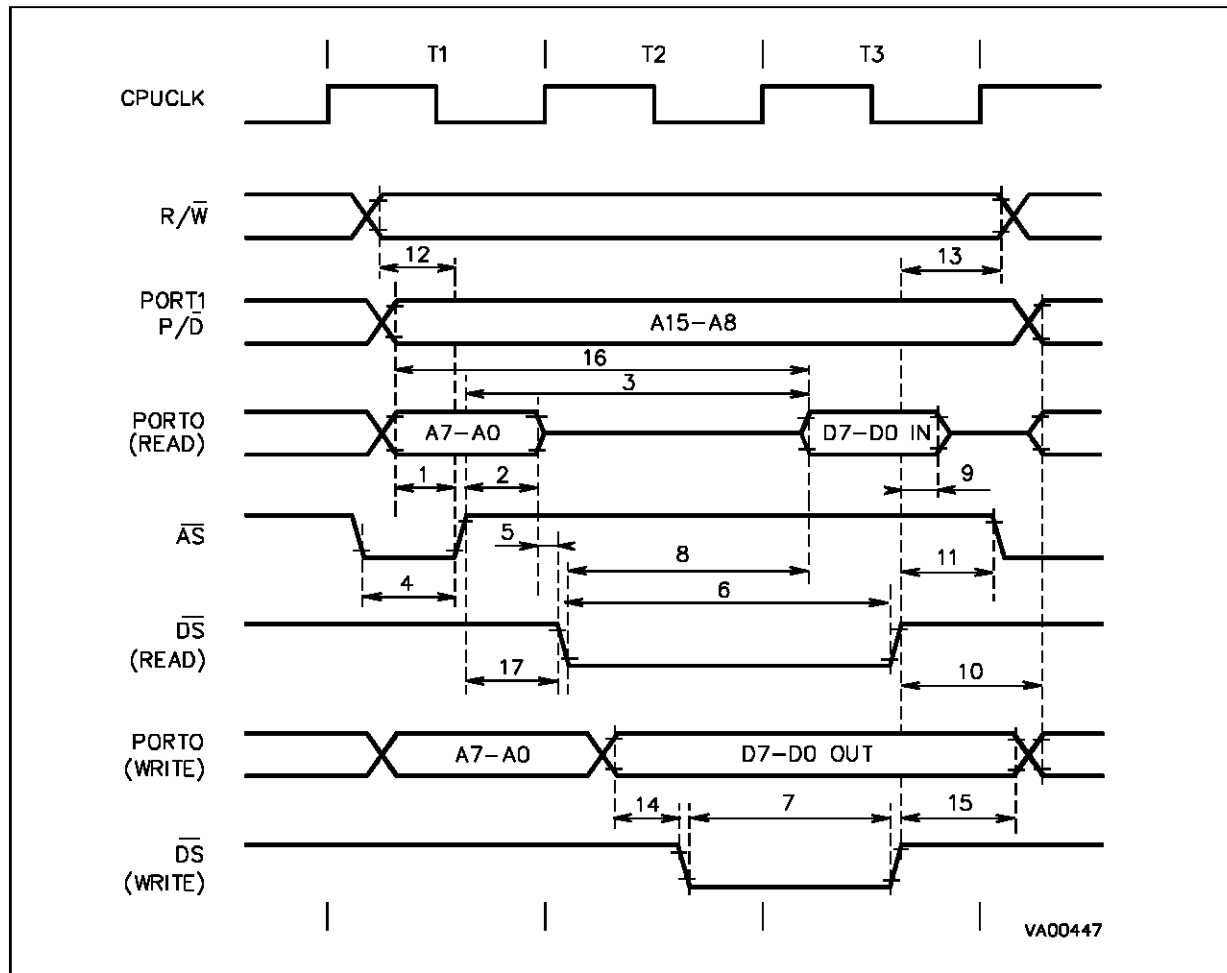

EXTERNAL WAIT TIMING

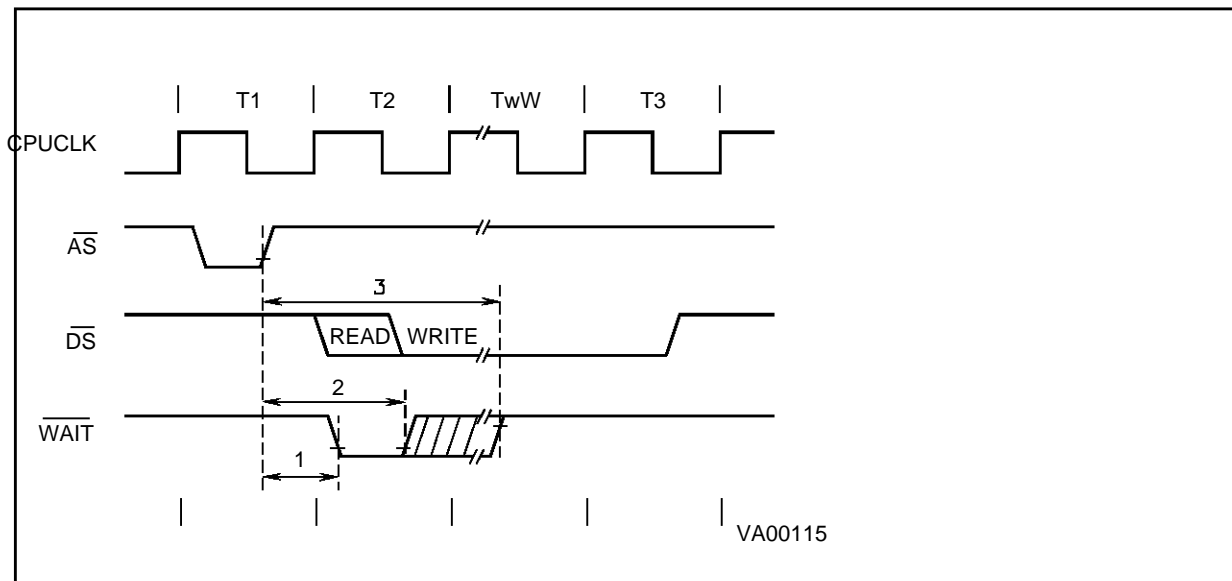

HANDSHAKE TIMING TABLE ($V_{DD} = 5V \pm 10\%$, $T_A = -40^\circ\text{C}$ to $+85^\circ\text{C}$, $C_{load} = 50\text{pF}$, $\text{INTCLK} = 12\text{MHz}$, Push-pull output configuration, unless otherwise specified)

N°	Symbol	Parameter	Value (Note)				Min.	Max.	Unit
			OSCIN Divided By 2		OSCIN Not Divided By 2				
			Min.	Max.	Min.	Max.			
1	T_{wRDY}	RDRDY, WRRDY Pulse Width in One Line Handshake	$2T_{pC}$ $(P+W+1) - 18$		T_{pC} $(P+W+1) - 18$		65	ns	
2	T_{wSTB}	$\overline{\text{RDSTB}}$, $\overline{\text{WRSTB}}$ Pulse Width	$2T_{pC} + 12$		$T_{pC} + 12$		95	ns	
3	T_{dST} (RDY)	$\overline{\text{RDSTB}}$, or $\overline{\text{WRSTB}} \uparrow$ to RDRDY or WRRDY \downarrow		$T_{pC} + 45$		$(T_{pC} - T_{wCL}) + 45$	87	ns	
4	T_{sPD} (RDY)	Port Data to RDRDY \uparrow Set-up Time	$(2P+2W+1)$ $T_{pC} - 25$		$T_{wCH} + (W+P)$ $T_{pC} - 25$		16	ns	
5	T_{sPD} (RDY)	Port Data to WRRDY \downarrow Set-up Time in One Line Handshake	43		43		43	ns	
6	T_{hPD} (RDY)	Port Data to WRRDY \downarrow Hold Time in One Line Handshake	0		0		0	ns	
7	T_{sPD} (STB)	Port Data to $\overline{\text{WRSTB}} \uparrow$ Set-up Time	10		10		10	ns	
8	T_{hPD} (STB)	Port Data to $\overline{\text{WRSTB}} \uparrow$ Hold Time	25		25		25	ns	
9	T_{dSTB} (PD)	$\overline{\text{RDSTBD}} \uparrow$ to Port Data Delay Time in Bidirectional Handshake		35		35	35	ns	
10	T_{dSTB} (PHZ)	$\overline{\text{RDSTB}} \uparrow$ to Port High-Z Delay Time in Bidirectional Handshake		25		25	25	ns	

Note: The value in the left hand two columns show the formula used to calculate the timing minimum or maximum from the oscillator clock period, prescale value and number of wait cycles inserted.

The value in the right hand two columns show the timing minimum and maximum for an external clock at 24 MHz divided by 2, prescaler value of zero and zero wait status.

Legend:

P = Clock Prescaling Value (R235.4.3.2)

W = Programmable Wait Cycles (R252.2.1.0/5,4,3) + External Wait Cycles

HANDSHAKE TIMING

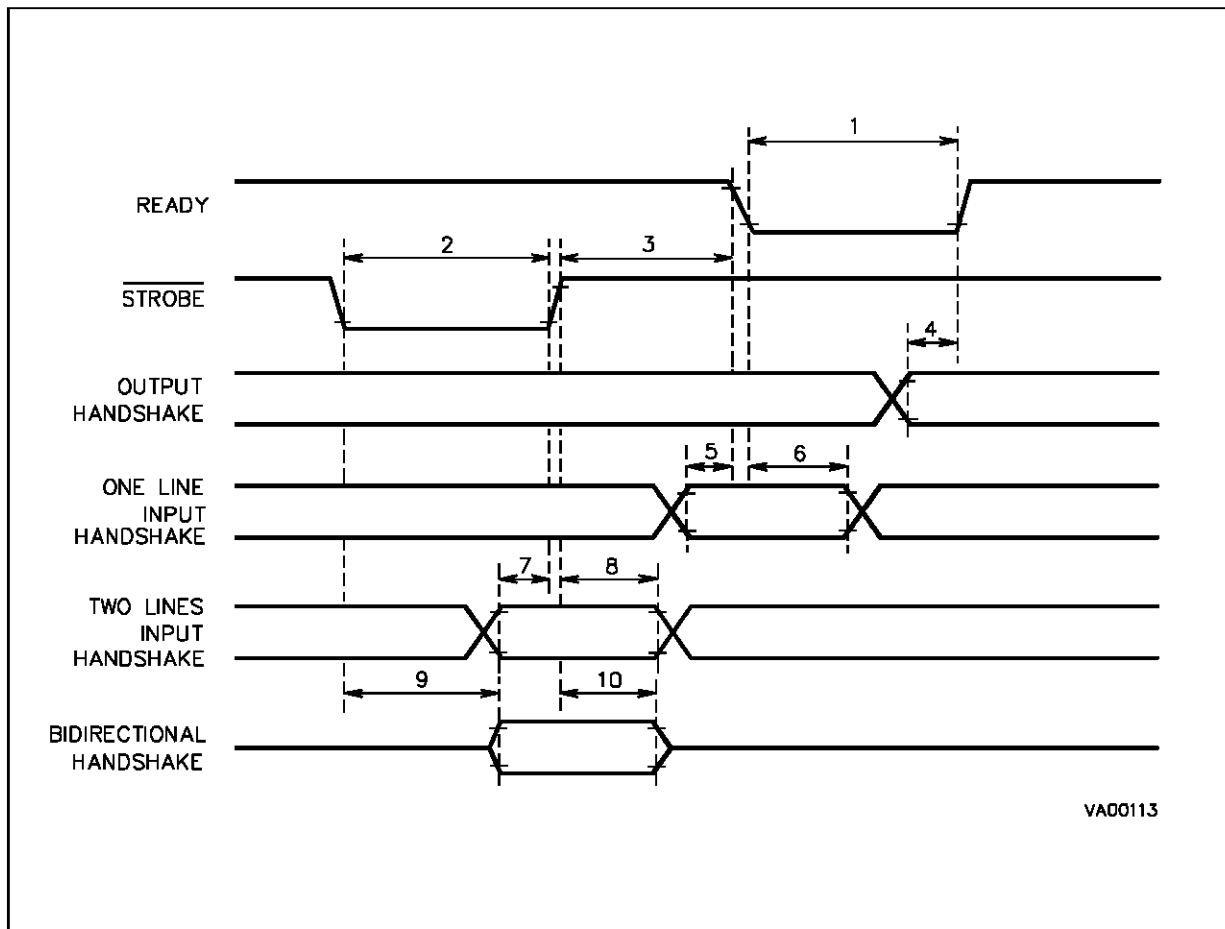

BUS REQUEST/ACKNOWLEDGE TIMING TABLE ($V_{DD} = 5V \pm 10\%$, $T_A = -40^{\circ}C$ to $+85^{\circ}C$, $C_{load} = 50pF$, $INTCLK = 12MHz$, Push-pull output configuration, unless otherwise specified)

N°	Symbol	Parameter	Value (Note)				Unit
			OSCIN Divided By 2	OSCIN Not Divided By 2	Min.	Max.	
1	TdBR (BACK)	$\overline{BREQ} \downarrow$ to $\overline{BUSACK} \downarrow$	$T_{pC}+8$	$T_{wCL}+12$	50		ns
			$T_{pC}(6P+2W+7)+65$	$T_{pC}(3P+W+3)+T_{wCL}+65$		360	ns
2	TdBR (BACK)	$\overline{BREQ} \uparrow$ to $\overline{BUSACK} \uparrow$	$3T_{pC}+60$	$T_{pC}+T_{wCL}+60$		185	ns
3	TdBACK (BREL)	$\overline{BUSACK} \downarrow$ to Bus Release	20	20		20	ns
4	TdBACK (BACT)	$\overline{BUSACK} \uparrow$ to Bus Active	20	20		20	ns

Note: The value left hand two columns show the formula used to calculate the timing minimum or maximum from the oscillator clock period, prescale value and number of wait cycles inserted.
The value right hand two columns show the timing minimum and maximum for an external clock at 24MHz divided by 2, prescale value of zero and zero wait status.

BUS REQUEST/ACKNOWLEDGE TIMING

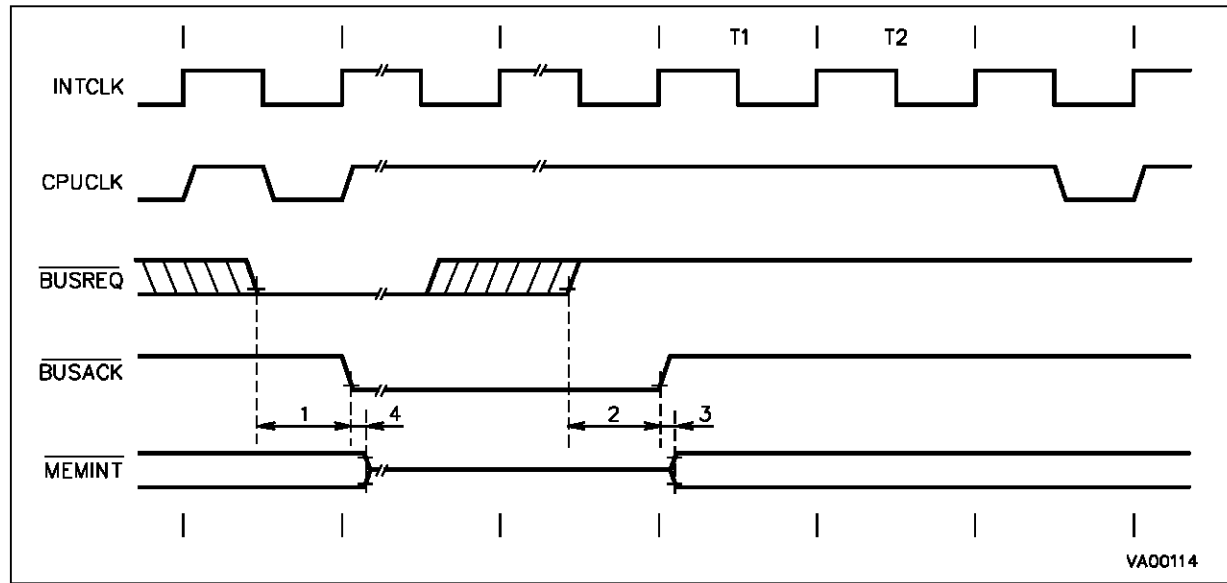

Note : MEMINT = Group of memory interface signals: AS, DS, R/W, P00-P07, P10-P17

ST90E27 - ST90E28

EXTERNAL INTERRUPT TIMING TABLE ($V_{DD} = 5V \pm 10\%$, $T_A = -40^\circ\text{C}$ to $+85^\circ\text{C}$, $C_{load} = 50\text{pF}$, $\text{INTCLK} = 12\text{MHz}$, Push-pull output configuration, unless otherwise specified)

N°	Symbol	Parameter	Value (Note)				Unit
			OSCIN Divided By 2 Min.	OSCIN Not Divided By 2 Min.	Min.	Max.	
1	TwLR	Low Level Minimum Pulse Width in Rising Edge Mode	$2T_{pC}+12$	$T_{pC}+12$	95		ns
2	TwHR	High Level Minimum Pulse Width in Rising Edge Mode	$2T_{pC}+12$	$T_{pC}+12$	95		ns
3	TwHF	High Level Minimum Pulse Width in Falling Edge Mode	$2T_{pC}+12$	$T_{pC}+12$	95		ns
4	TwLF	Low Level Minimum Pulse Width in Falling Edge Mode	$2T_{pC}+12$	$T_{pC}+12$	95		ns

Note: The value left hand two columns show the formula used to calculate the timing minimum or maximum from the oscillator clock period, prescale value and number of wait cycles inserted.
The value right hand two columns show the timing minimum and maximum for an external clock at 24 MHz divided by 2, prescale value of zero and zero wait status.

EXTERNAL INTERRUPT TIMING

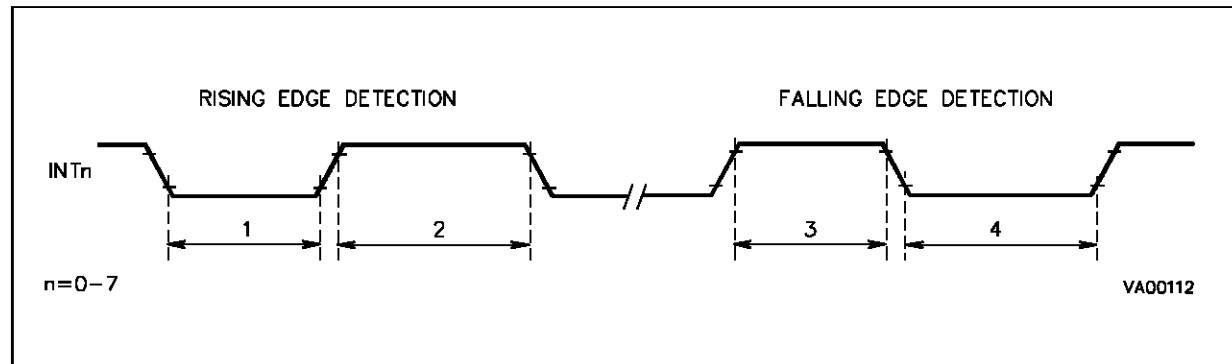

SPI TIMING TABLE ($V_{DD} = 5V \pm 10\%$, $T_A = -40^{\circ}C$ to $+85^{\circ}C$, $C_{load} = 50pF$, $INTCLK = 12MHz$, Output Alternate Function set as Push-pull)

N°	Symbol	Parameter	Value		Unit
			Min.	Max.	
1	TsDI	Input Data Set-up Time	100		ns
2	ThDI (1)	Input Data Hold Time	1/2 TpC+100		ns
3	TdOV	SCK to Output Data Valid		100	ns
4	ThDO	Output Data Hold Time	-20		ns
5	TwSKL	SCK Low Pulse Width	300		ns
6	TwSKH	SCK High Pulse Width	300		ns

Note: 1. TpC is the OSCIN Clock period.

SPI TIMING

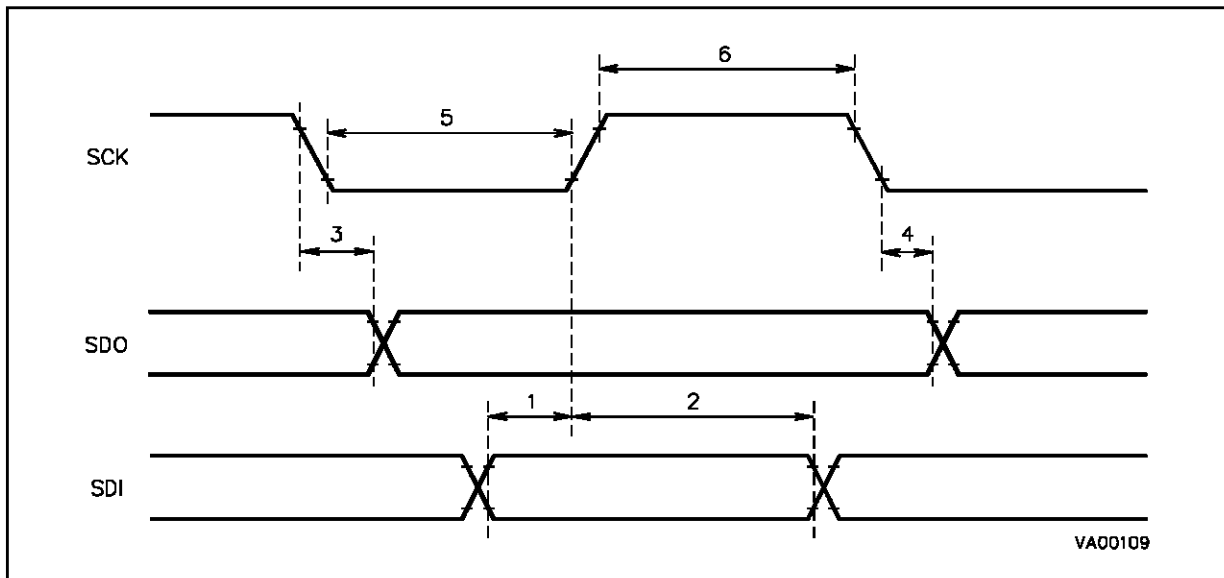

ST90E27 - ST90E28

WATCHDOG TIMING TABLE ($V_{DD} = 5V \pm 10\%$, $T_A = -40^\circ\text{C}$ to $+85^\circ\text{C}$, $C_{load} = 50\text{pF}$, $CPUCLK = 12\text{MHz}$, Push-pull output configuration, unless otherwise specified)

N°	Symbol	Parameter	Values		Unit
			Min.	Max.	
1	T_{wWDOL}	WDOUT Low Pulse Width	620		ns
2	T_{wWDOH}	WDOUT High Pulse Width	620		ns
3	T_{wWDIL}	WDIN High Pulse Width	350		ns
4	T_{wWDIH}	WDIN Low Pulse Width	350		ns

WATCHDOG TIMING

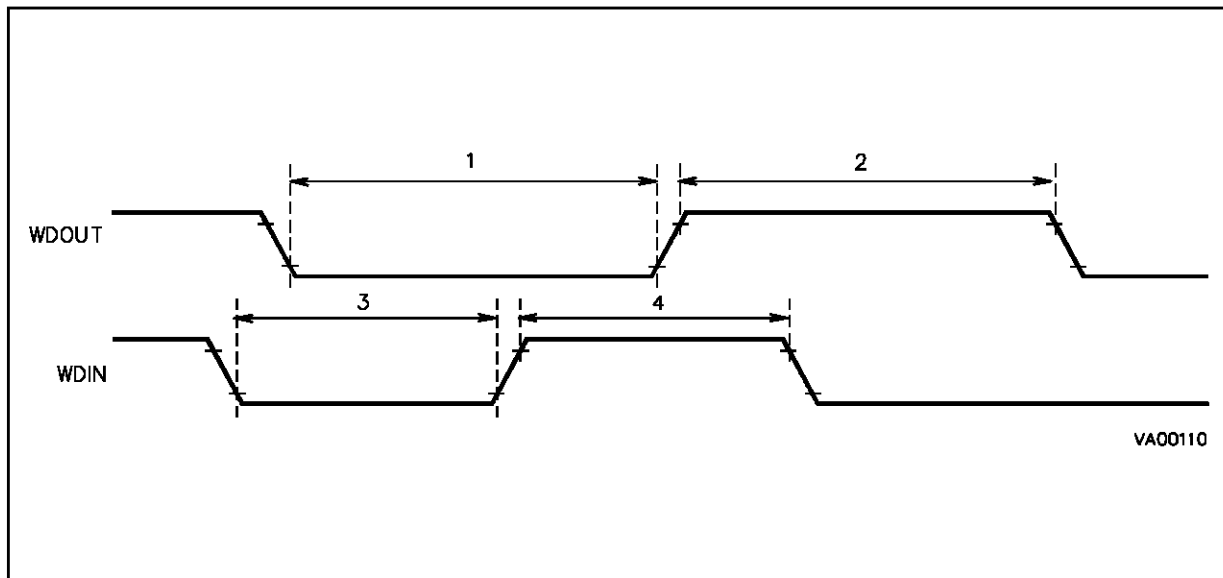

PACKAGE MECHANICAL DATA

44-Pin Ceramic Leadless Chip Carrier Package with Window

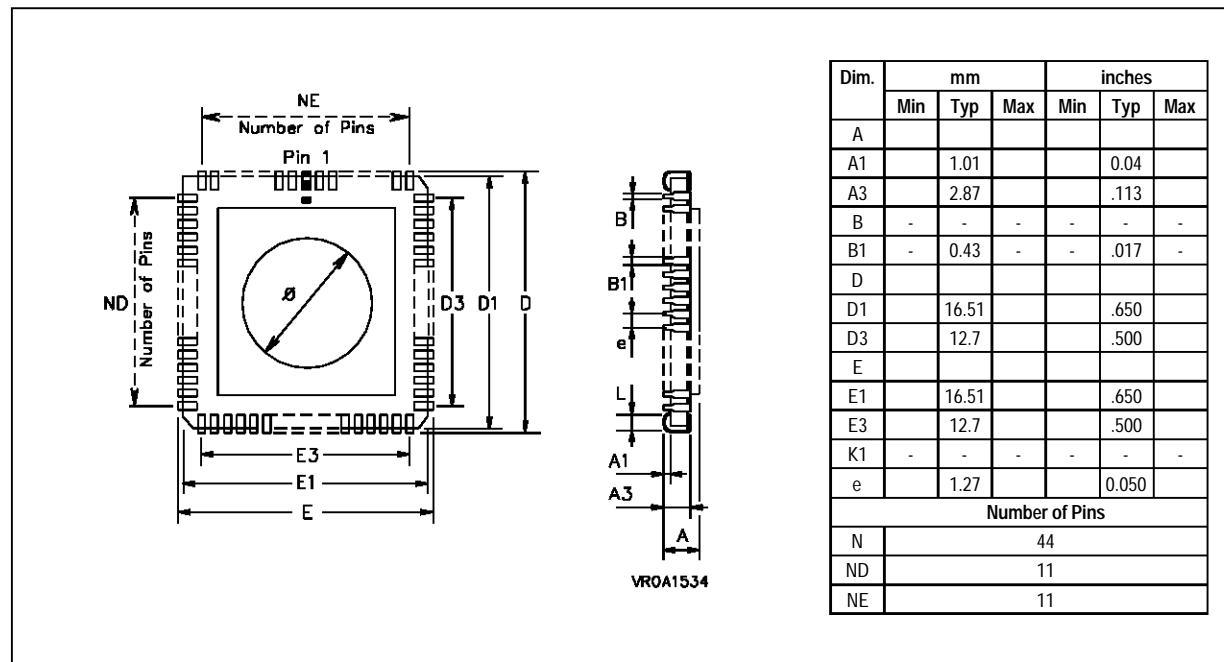

40-Pin Ceramic Dual In Line Package with Window

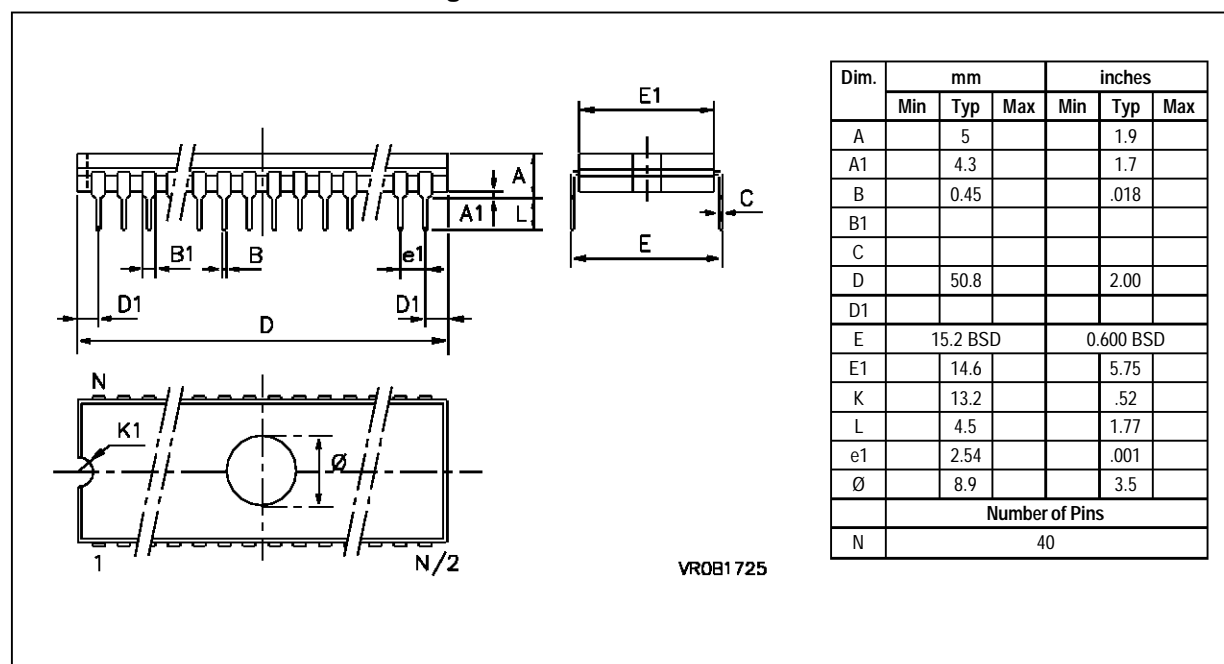

ST90E27 - ST90E28

PACKAGE MECHANICAL DATA (Continued)

56-Pin Ceramic Dual In Line Package, 600 Mil Width

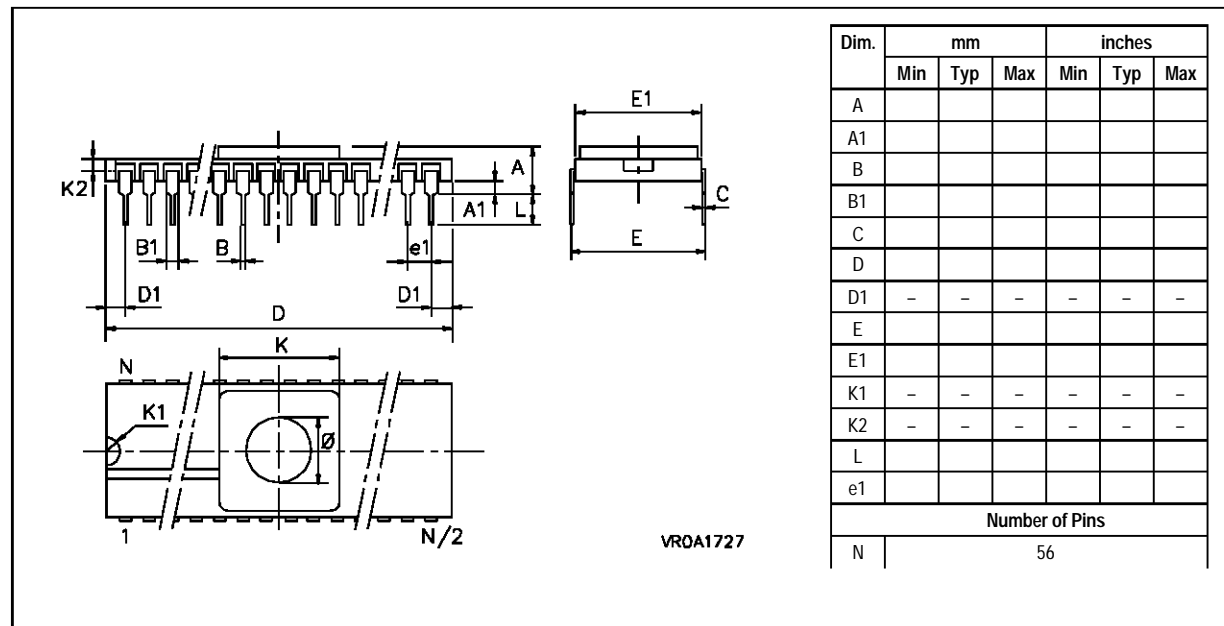

ORDERING INFORMATION

Sales Type	Frequency	Temperature Range	Package
ST90E27D0	24MHz	25°C	CDIP40-W
ST90E28L0		25°C	CLCC44-W
ST90E28D0		25°C	CSDIP56-W
ST90T27B6		-40°C to + 85°C	PDIP40
ST90T28C6		-40°C to + 85°C	PLCC44
ST90T28B6		-40°C to + 85°C	PDIP56

ROMLESS HCMOS MCU WITH RAM

- Register oriented 8/16 bit CORE with RUN, WFI and HALT modes
- Minimum instruction cycle time:500ns (12MHz internal)
- ROMless to allow maximum external memory flexibility
- Internal Memory :
RAM 256 bytes
224 general purpose registers available as RAM, accumulators or index pointers (register file)
- 56-pin Plastic Dual-In-Line package
- DMA controller, Interrupt handler and Serial Peripheral Interface as standard features
- 40 fully programmable I/O pins
- Up to 8 external plus 1 non-maskable interrupts
- 16 bit Timer with 8 bit Prescaler, able to be used as a Watchdog Timer
- One 16 bit Multifunction Timer, with an 8 bit prescaler and 12 operating modes
- Serial Communications Interface with asynchronous and synchronous capability
- Rich Instruction Set and 14 Addressing modes
- Division-by-Zero trap generation
- Versatile development tools, including assembler, linker, C-compiler, archiver, graphic oriented debugger and hardware emulators
- Real Time Operating System

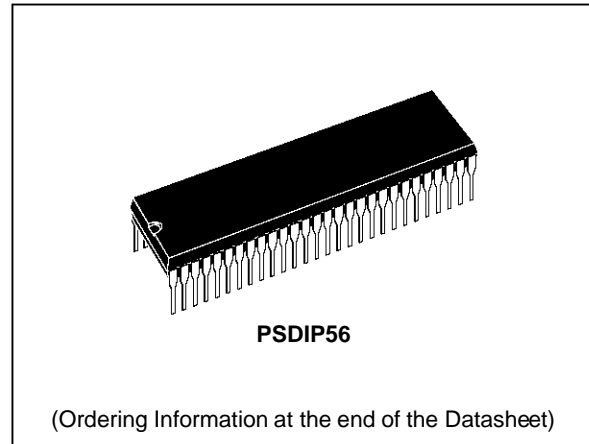
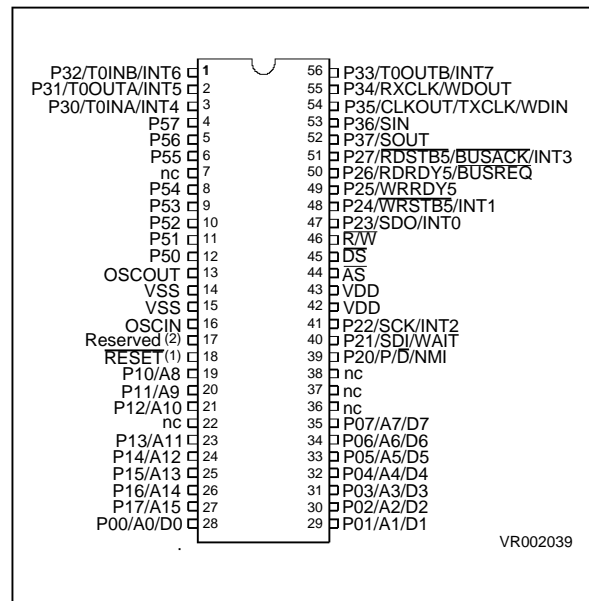

Figure 1. 56-Pin PDIP Package)



17.1 GENERAL DESCRIPTION

The ST90R28 is a ROMLESS member of the ST9 family of microcontrollers, completely developed and produced by SGS-THOMSON Microelectronics using a proprietary n-well HCMOS process.

The ROMLESS part may be used for the prototyping and pre-production phases of development, and offers the maximum in program flexibility in production systems.

The ST90R28 is fully compatible with the ST902x ROM version and this datasheet will thus provide only information specific to the ROMLESS device.

THE READER IS ASKED TO REFER TO THE DATASHEET OF THE ST902x ROM-BASED DEVICE.

The ROMLESS ST90R28 can be configured as a microcontroller able to manage external memory, or as a parallel processing element in a system with other processors and peripheral controllers.

The nucleus of the ST90R28 is the advanced Core which includes the Central Processing Unit (CPU), the Register File, a 16 bit Timer/Watchdog with 8 bit Prescaler, a Serial Peripheral Interface supporting S-BUS, I²C-bus and IM-bus Interface, plus two

8 bit I/O ports. The Core has independent memory and register buses allowing a high degree of pipelining to add to the efficiency of the code execution speed of the extensive instruction set.

The powerful I/O capabilities demanded by microcontroller applications are fulfilled by the ST90R28 with up to 40 I/O lines dedicated to digital Input/Output. These lines are grouped into up to five 8 bit I/O Ports and can be configured on a bit basis under software control to provide timing and status signals, address lines, timer inputs and outputs, analog inputs, external interrupts and serial or parallel I/O with or without handshake.

Three memory spaces are available: Program Memory (external), Data Memory (internal and external) and the Register File, which includes the control and status registers of the on-chip peripherals.

The 16 bit MultiFunction Timer with an 8 bit Prescaler and 12 operating modes allow simple use for complex waveform generation and measurement, PWM functions and many other system timing functions by the usage of the two associated DMA channels for each timer.

Figure 17-2. Block Diagram

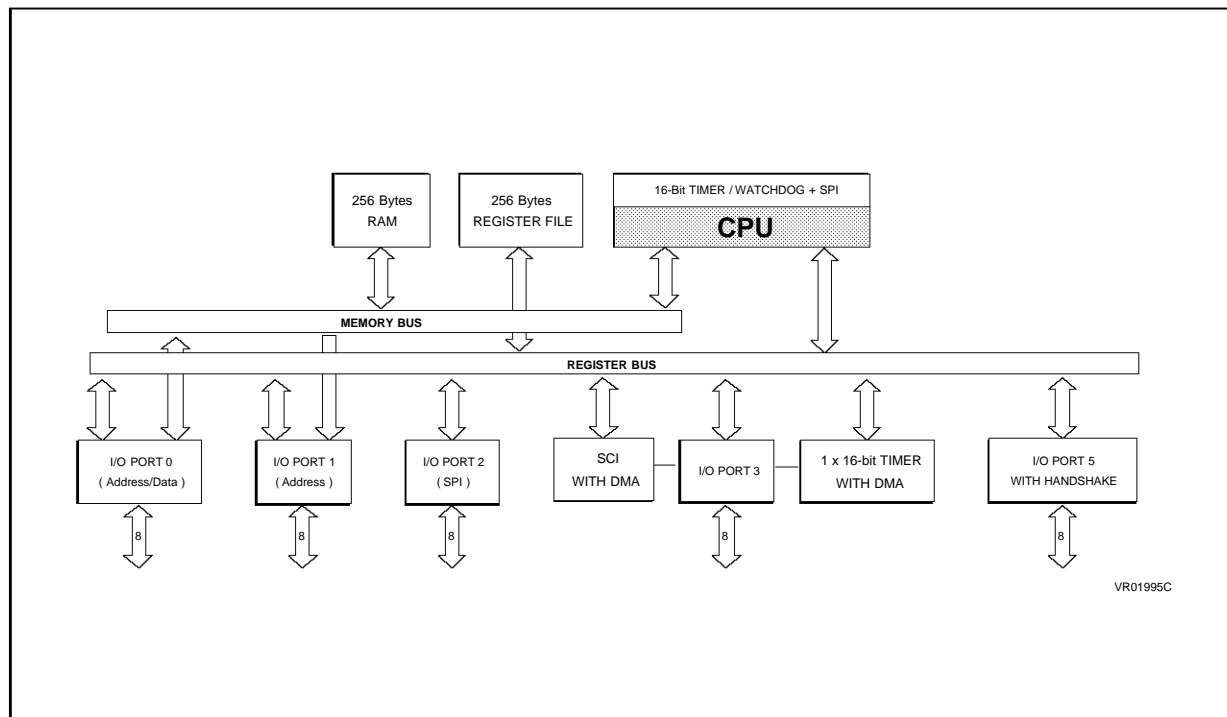

GENERAL DESCRIPTION (Continued)

Completing the device is a full duplex Serial Communications Interface with an integral 110 to 375000 baud rate generator, asynchronous and 1.5Mbyte/s synchronous capability (fully programmable format) and associated address/wake-up option, plus two DMA channels.

17.2 PIN DESCRIPTION

\overline{AS} . *Address Strobe (output, active low, 3-state).* Address Strobe is pulsed low once at the beginning of each memory cycle. The rising edge of \overline{AS} indicates that address, Read/Write (R/ \overline{W}), and Data Memory signals are valid for program or data memory transfers. Under program control, \overline{AS} can be placed in a high-impedance state along with Port 0 and Port 1, Data Strobe (\overline{DS}) and R/ \overline{W} .

\overline{DS} . *Data Strobe (output, active low, 3-state).* Data Strobe provides the timing for data movement to or from Port 0 for each memory transfer. During a write cycle, data out is valid at the leading edge of \overline{DS} . During a read cycle, Data In must be valid prior to the trailing edge of \overline{DS} . When the ST90R28 accesses on-chip Data memory, \overline{DS} is held high during the whole memory cycle. It can be placed in a high impedance state along with Port 0, Port 1, \overline{AS} and R/ \overline{W} .

R/ \overline{W} . *Read/Write (output, 3-state).* Read/Write determines the direction of data transfer for memory transactions. R/ \overline{W} is low when writing to program or data memory, and high for all other transactions. It can be placed in a high impedance state along with Port 0, Port 1, \overline{AS} and \overline{DS} .

RESET. *Reset (input, active low).* The ST9 is initialised by the Reset signal. With the deactivation of RESET, program execution begins from the Program memory location pointed to by the vector contained in program memory locations 00h and 01h.

OSCIN, OSCOUT. *Oscillator (input and output).* These pins connect a parallel-resonant crystal (24MHz maximum), or an external source to the on-chip clock oscillator and buffer. OSCIN is the input of the oscillator inverter and internal clock generator; OSCOUT is the output of the oscillator inverter.

V_{DD}. Main Power Supply Voltage (5V±10%)

V_{SS}. Digital Circuit Ground.

AD0-AD7, (P0.0-P0.7) *Address/Data Lines (Input/Output, TTL or CMOS compatible).* 8 lines providing a multiplexed address and data bus, under control of the \overline{AS} and \overline{DS} timing signals.

A8-A15 *Address Lines (Output, TTL or CMOS compatible).* 8 lines providing non-multiplexing address bus, under control of the \overline{AS} and \overline{DS} timing signals.

P2.0-P2.7 P3.0-P3.7, P4.0-P4.7, P5.0-P5.7, P7.0-P7.7 *I/O Port Lines (Input/Output, TTL or CMOS compatible).* 40 lines grouped into I/O ports of 8 bits, bit programmable under program control as general purpose I/O or as Alternate functions (see next section).

17.3 I/O PORT ALTERNATE FUNCTIONS

Each pin of the I/O ports of the ST90R28 may assume software programmable Alternative Functions as shown in the Pin Configuration Drawings. Table 1 shows the Functions allocated to each I/O Port pins.

17.4 MEMORY

The memory of the ST90R28 is functionally divided into two areas, the Register File and Memory. The

PIN DESCRIPTION (Continued)

Table 17-1. I/O Port Alternate Function Summary

I/O PORT	Name	Function	Alternate Function	Pin Assignment
				SDIP56
P0.0	A0/D0	I/O	Address/Data bit 0 mux	28
P0.1	A1/D1	I/O	Address/Data bit 1 mux	29
P0.2	A2/D2	I/O	Address/Data bit 2 mux	30
P0.3	A3/D3	I/O	Address/Data bit 3 mux	31
P0.4	A4/D4	I/O	Address/Data bit 4 mux	32
P0.5	A5/D5	I/O	Address/Data bit 5 mux	33
P0.6	A6/D6	I/O	Address/Data bit 6 mux	34
P0.7	A7/D7	I/O	Address/Data bit 7 mux	35
P1.0	A8	O	Address bit 8	19
P1.1	A9	O	Address bit 9	20
P1.2	A10	O	Address bit 10	21
P1.3	A11	O	Address bit 11	23
P1.4	A12	O	Address bit 12	24
P1.5	A13	O	Address bit 13	25
P1.6	A14	O	Address bit 14	26
P1.7	A15	O	Address bit 15	27
P2.0	NMI	I	Non-Maskable Interrupt	39
P2.0	P/D	O	Program/Data Space Select	39
P2.1	SDI	I	SPI Serial Data In	40
P2.1	WAIT	I	External Wait Input	40
P2.2	INT2	I	External Interrupt 2	41
P2.2	SCK	O	SPI Serial Clock	41
P2.3	INT0	I	External Interrupt 0	47
P2.3	SDO	O	SPI Serial Data Out	47
P2.4	INT1	I	External Interrupt 1	48
P2.4	WRSTB5	I	Handshake Write Strobe P5	48
P2.5	WRRDY5	O	Handshake Write Ready P5	49
P2.6	RDRDY5	O	Handshake Read Ready P5	50

PIN DESCRIPTION (Continued)

Table 17.1. I/O Port Alternate Function Summary (Continued)

I/O PORT	Name	Function	Alternate Function	Pin Assignment
				SDIP56
P2.6	$\overline{\text{BUSREQ}}$	I	External Bus Request	50
P2.7	INT3	I	External Interrupt 1	51
P2.7	$\overline{\text{RDSTB5}}$	I	Handshake Read Strobe P5	51
P2.7	$\overline{\text{BUSACK}}$	O	External Bus Acknowledge	51
P3.0	INT4	I	External Interrupt 4	3
P3.0	T0INA	I	MF Timer 0 Input A	3
P3.1	INT5	I	External Interrupt 5	2
P3.1	T0OUTA	O	MF Timer 0 Output A	2
P3.2	INT6	I	External Interrupt 6	1
P3.2	T0INB	I	MF Timer 0 Input B	1
P3.3	INT7	I	External Interrupt 7	56
P3.3	T0OUTB	O	MF Timer 0 Output B	56
P3.4	RXCLK	I	SCI Receive Clock Input	55
P3.4	WDOUT	O	T/WD Output	55
P3.5	CLKOUT	O	SCI Byte Sync Clock Output	54
P3.5	TXCLK	I	SCI Transmit Clock Input	54
P3.5	WDIN	I	T/WD Input	54
P3.6	SIN	I	SCI Serial Input	53
P3.7	SOUT	O	SCI Serial Output	52
P5.0		O	I/O Handshake Port 5	12
P5.1		O	I/O Handshake Port 5	11
P5.2		O	I/O Handshake Port 5	10
P5.3		O	I/O Handshake Port 5	9
P5.4		O	I/O Handshake Port 5	8
P5.5		O	I/O Handshake Port 5	6
P5.6		O	I/O Handshake Port 6	5
P5.7		O	I/O Handshake Port 7	4

ST90R28

Memory may optionally be divided into two spaces, each having a maximum of 65,536 bytes. The two memory spaces are separated by function, one space for Program code, the other for Data. The ST90R28 addresses all program memory in the external PROGRAM space. The DATA space includes the 256 bytes of on-chip RAM memory at memory addresses 00h through 00FFh.

The External Memory spaces are addressed using the multiplexed address and data buses on Ports 0 and 1. Additional Data Memory may be decoded externally by using the P/D Alternate Function output. The on-chip general purpose (GP) Registers may be used as RAM memory.

Figure 17-3. Memory Spaces

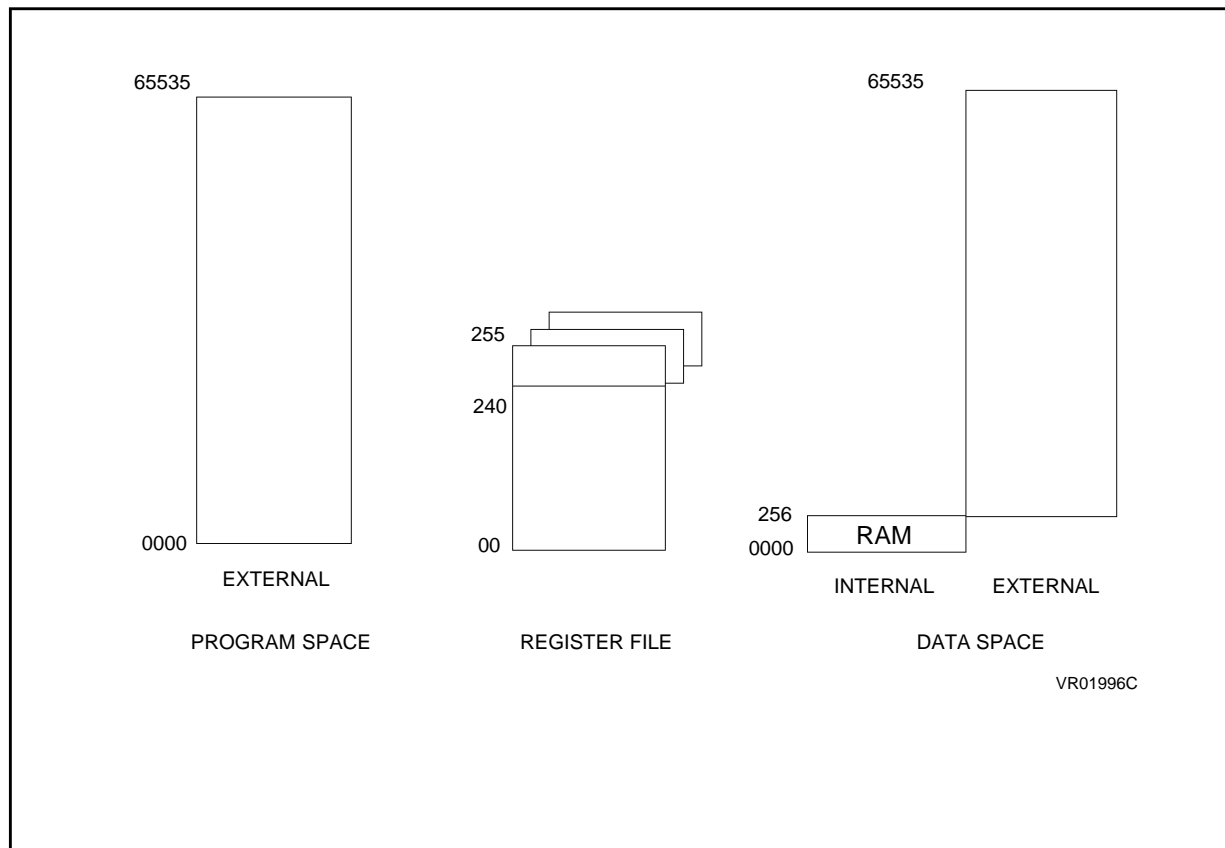

56-Pin Plastic Shrink Dual In Line Package

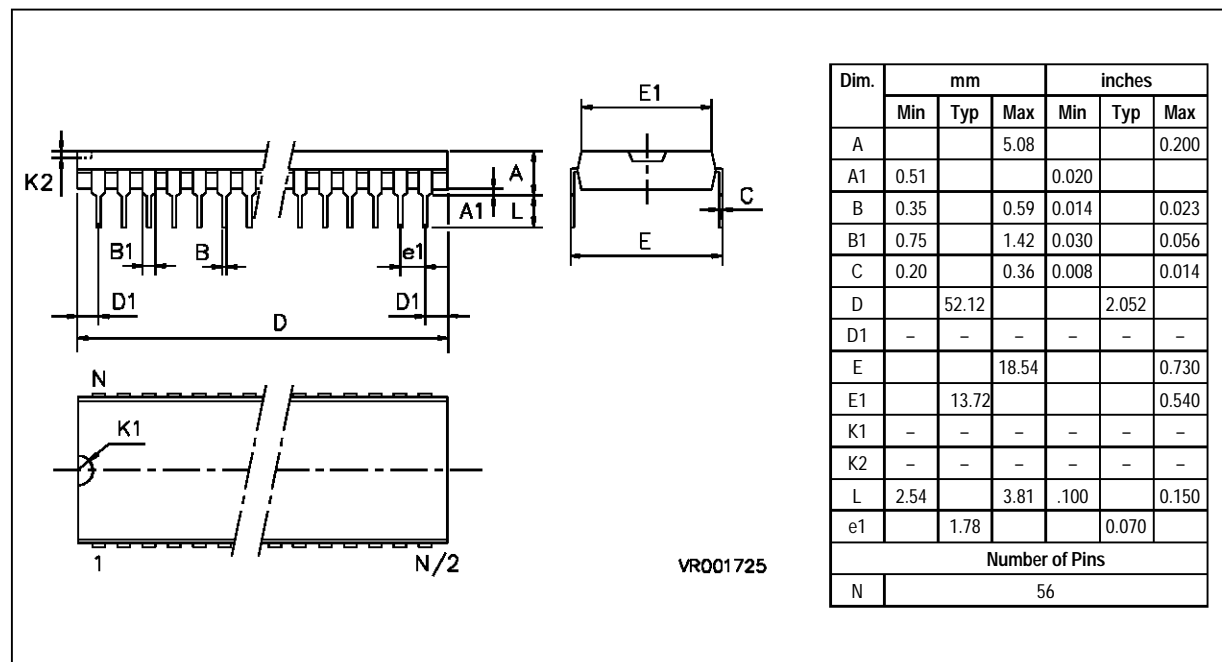

ORDERING INFORMATION

Sales Type	Frequency	Temperature Range	Package
ST90R28B1	24MHz	0°C to + 70°C	PSDIP56
ST90R28B6		-40°C to + 85°C	PSDIP56

Information furnished is believed to be accurate and reliable. However, SGS-THOMSON Microelectronics assumes no responsibility for the consequences of use of such information nor for any infringement of patents or other rights of third parties which may result from its use. No license is granted by implication or otherwise under any patent or patent rights of SGS-THOMSON Microelectronics. Specifications mentioned in this publication are subject to change without notice. This publication supersedes and replaces all information previously supplied. SGS-THOMSON Microelectronics products are not authorized for use as critical components in life support devices or systems without the express written approval of SGS-THOMSON Microelectronics.

© 1995 SGS-THOMSON Microelectronics - All rights reserved.

Purchase of I²C Components by SGS-THOMSON Microelectronics conveys a license under the Philips I²C Patent. Rights to use these components in an I²C system is granted provided that the system conforms to the I²C Standard Specification as defined by Philips.

SGS-THOMSON Microelectronics Group of Companies

Australia - Brazil - China - France - Germany - Hong Kong - Italy - Japan - Korea - Malaysia - Malta - Morocco
The Netherlands - Singapore - Spain - Sweden - Switzerland - Taiwan - Thailand - United Kingdom - U.S.A.